

Main Propulsion System

MPS 2102

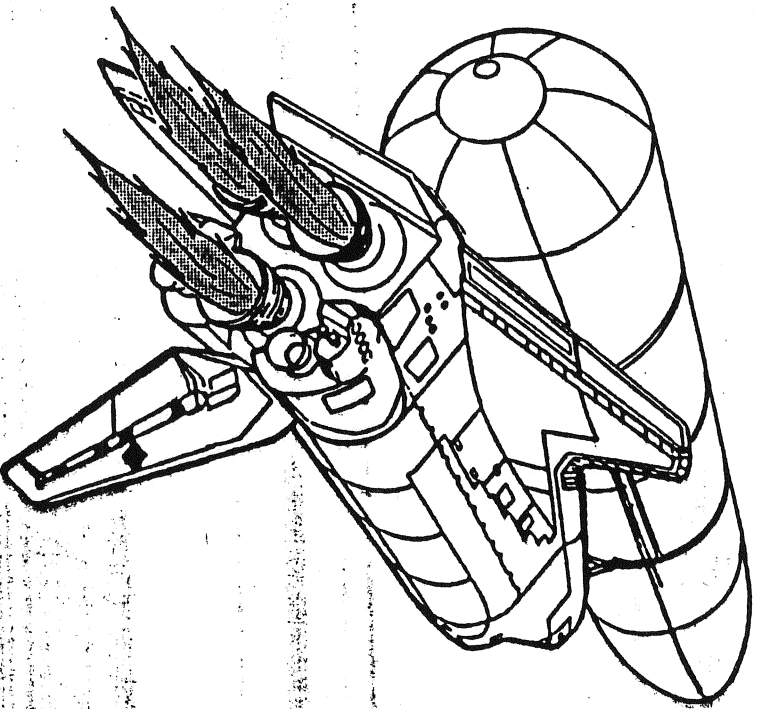

March 1988

Mission Operations Directorate
Training Division
Flight Training Branch



National Aeronautics and
Space Administration

Lyndon B. Johnson Space Center
Houston, Texas



Main Propulsion System

MPS 2102



Dennis Beckman, Head
Control/Propulsion Section



Frank E. Hughes, Chief
Flight Training Branch

March 1988

Mission Operations Directorate
Training Division
Flight Training Branch

Bill Russell



Preface

This training manual is intended for self-study by Space Shuttle crewmembers, flight controllers, and instructors on the main propulsion system (MPS). It is part of a series of lessons in the Orbiter support systems training course. You should refer to that training flow to ensure that you take the lessons in the suggested order.

This book is a generic training document; all numerical data, displays, and checklist references are intended only as examples and do not necessarily reflect any particular flight. Specific data can be found in the current Flight Data File (FDF).

Questions are provided at the end of most sections to help you review the material and evaluate your comprehension. Answers are also provided on the following pages. Appendix A is the MPS summary sheet included as a quick reference aid.

A lesson critique sheet is also included at the end of this manual. Inputs on the lesson critique sheet would be appreciated.

If you have any additional questions or comments on this training manual, please direct them to:

John T. Sims
Flight Training Branch
JSC, bldg 4, room 211
Mail code DG6
Phone (713) 483-2904



Contents

Section	Page	Section	Page
1	Introduction		1-1
2	System Description		2-1
	Space Shuttle Main Engine		2-2
	Low Pressure Fuel Turbopump		2-3
	High Pressure Fuel Turbopump		2-3
	Low Pressure Oxidizer Turbopump		2-3
	High Pressure Oxidizer Turbopump		2-3
	Fuel and Oxidizer Preburners		2-3
	Hot Gas Manifold		2-3
	Main Combustion Chamber		2-3
	Nozzle		2-3
	Oxidizer Heat Exchanger		2-3
	Valves		2-3
	Main Engine Fuel Flow		2-4
	Main Engine Oxidizer Flow		2-5
	Main Engine Controller		2-6
	Main Engine Command Flow		2-8
	Main Engine Data Flow		2-9
	Propellant Management System		2-10
	Propellant Feedline Manifolds		2-12
	Feedline Disconnect Valves		2-12
	Fill/Drain Valves		2-13
	Manifold Relief Lines		2-13
	Backup LH2 Dump Valves		2-14
	Topping Valve		2-14
	LH2 Bleed Valves		2-14
	Prevalves		2-16
	Ullage Pressure System		2-17
	Manifold Pressure Valves		2-20
	Valve Types		2-21
	Helium System		2-22
	Supply Tanks		2-23
3		3	
		Helium Isolation Valves	2-24
		Pneumatic Left Engine	
		Helium Crossover Valve	2-26
		Helium Interconnect Valves	2-26
		External Tank	2-28
		Thrust Vector Control	2-28
		Command Flow	2-30
		Hydraulic Interface	2-32
		Controls and Displays	2-33
4		4	
		System Operations	3-1
		Prelaunch	3-2
		Powered Flight	3-5
		Post-MECO	3-8
		Entry	3-19
		System Malfunctions	4-1
		MPS Data	4-2
		Stuck Throttles	4-4
		Multi: MPS CMD/Data (No MECO Confirm)	4-12
		Engine Failure	4-14
		LH2 ET ULL PRESS	4-18
		LH2/L02 MANF PRESS High	4-20
		MPS He TK LK (Pre-ET SEP)	4-22
		MPS He TK LK (Post-ET SEP)	4-25
		ET SEP MAN	4-25
		ET SEP INH	4-27
		MPS CW	4-28
		Appendices	
		A MPS Summary Sheet	A-1
		B Acronyms and Abbreviations	B-1



Section 1: Introduction

The main propulsion system (MPS), assisted by the two solid rocket boosters (SRBs), provides the initial thrust required from lift-off to orbit insertion. At lift-off, the three main engines are burning in parallel with the SRBs. This is first-stage ascent. After about 2 minutes, the SRBs burn out, separate from the vehicle, and are recovered for use on a later flight. Second-stage ascent, using only the main engines, continues until a predetermined velocity is achieved. At that time main engine

cutoff (MECO) is initiated, and the external tank (ET) is jettisoned, enters the Earth's atmosphere, breaks up, and impacts in a remote ocean area. It is not recovered. See figure 1-1.

After MECO, the orbital maneuvering system (OMS) is ignited to provide the final thrust needed for orbit insertion. During the burn (called the OMS-1 burn), the unused MPS propellants trapped in the Orbiter are automatically dumped overboard. On direct insertion flights that do not require an OMS-1 burn, the crew starts the dump manually. After the burn, the crew will vacuum inert the MPS by opening valves that allow any remaining propellants to be vented into space.

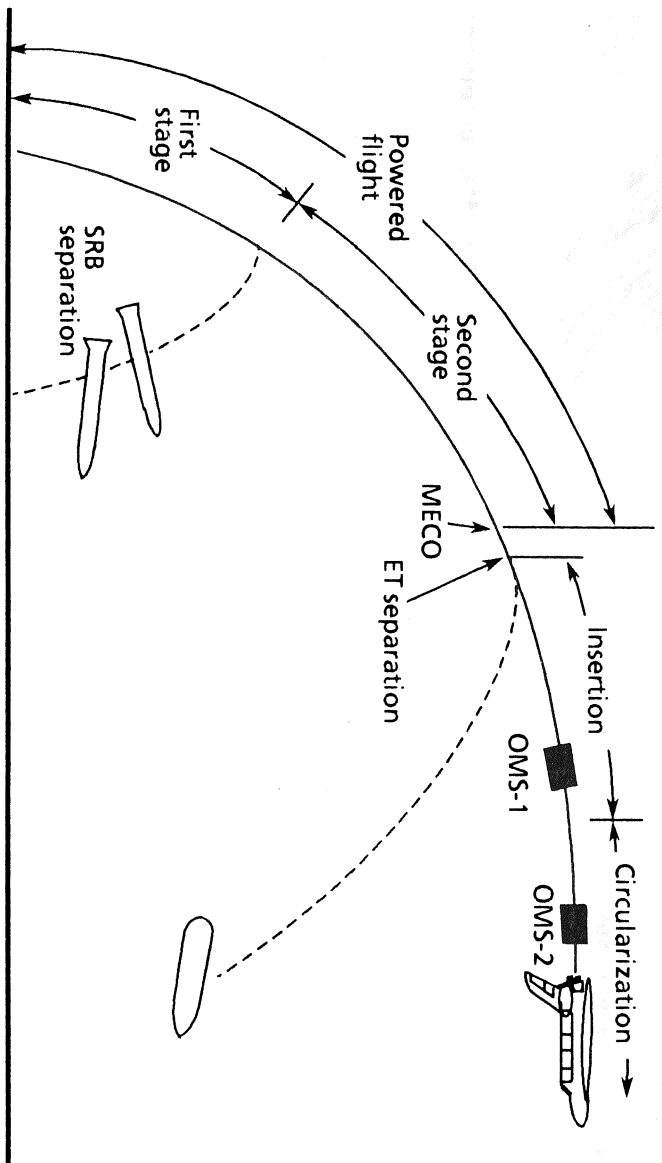

Figure 1-1.- Nominal ascent profile.

TD345*001

During entry, the MPS propellant lines are repressurized with helium to prevent contaminants from being drawn into the lines. MPS helium is also used to purge the aft fuselage and OMS pods of any potentially explosive gases that may have accumulated during the flight, such as residual MPS hydrogen or hydrazine from the APUs.

The MPS consists of three rocket engines, an external propellant tank, a propellant management system used to transport fuel and oxidizer from the tank to the engines, and a multipurpose helium system. Most of the MPS is located at the aft end of the Orbiter beneath the vertical stabilizer, except for the ET which serves as the structural backbone of the Shuttle during ascent. See figure 1-2.

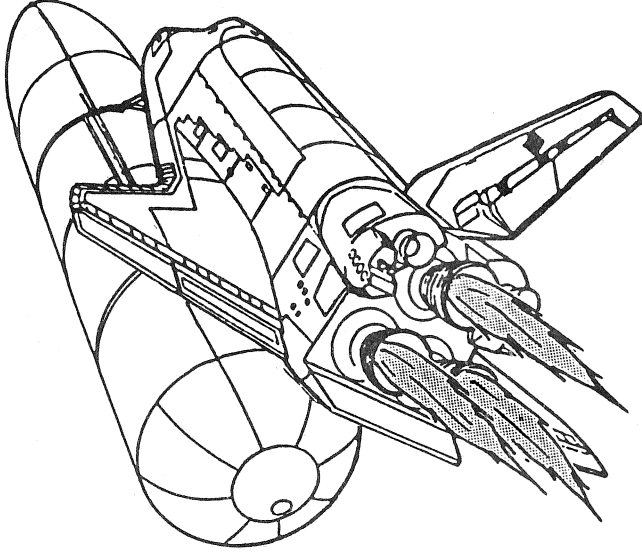
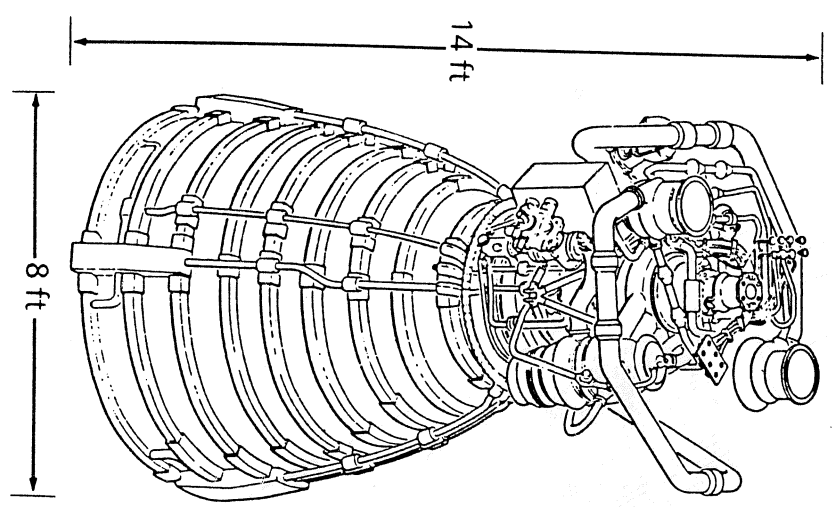

Figure 1-2.- Main propulsion system.

Each of the three main engines is approximately 14 feet long and has a nozzle about 8 feet in diameter. See figure 1-3. The engines use liquid hydrogen (LH2) for fuel and liquid oxygen (LO2) as an oxidizer. They can be throttled over a range of 65 to 109 percent of

their rated power level in one percent increments. Each engine can also be gimbaled $\pm 10.5^\circ$ in pitch and $\pm 8.5^\circ$ in yaw for steering the vehicle. The engines, shown in figure 1-4, are generally referred to as the center (engine 1), left (engine 2), and right (engine 3).



TD345*003

Figure 1-3. - Space Shuttle main engine.

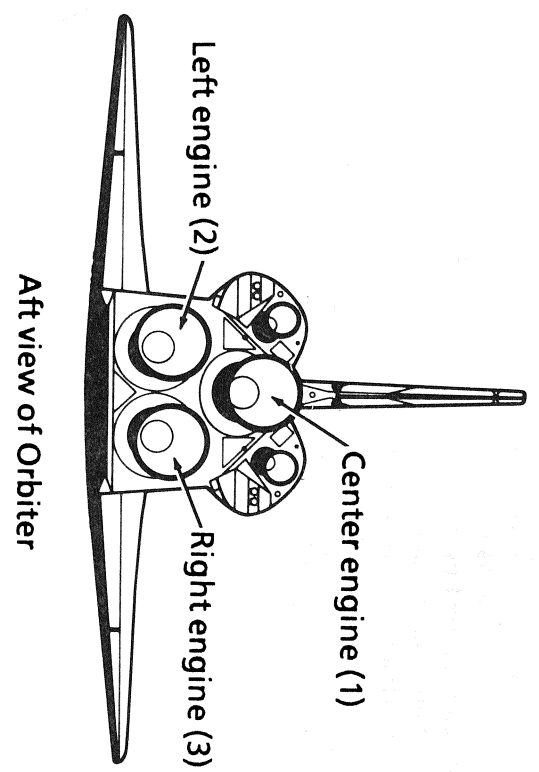

TD345*003C

Figure 1-4. - Main engine numbering system.

The ET contains the LH2 and LO2 that are burned in the main engines. At 154 feet long and 27.5 feet in diameter, it is the largest component of the Space Shuttle vehicle. See figure 1-5. Since the ET is used only once, it contains a minimum amount of active components.

The propellant management system in the Orbiter is a collection of manifolds, valves, and distribution lines that connect the main engines to the ET and control the flow of propellants between them. During prelaunch, this system is also used to load the propellants in the ET and, post-MECO, it controls the propellant dump and vacuum inerting.

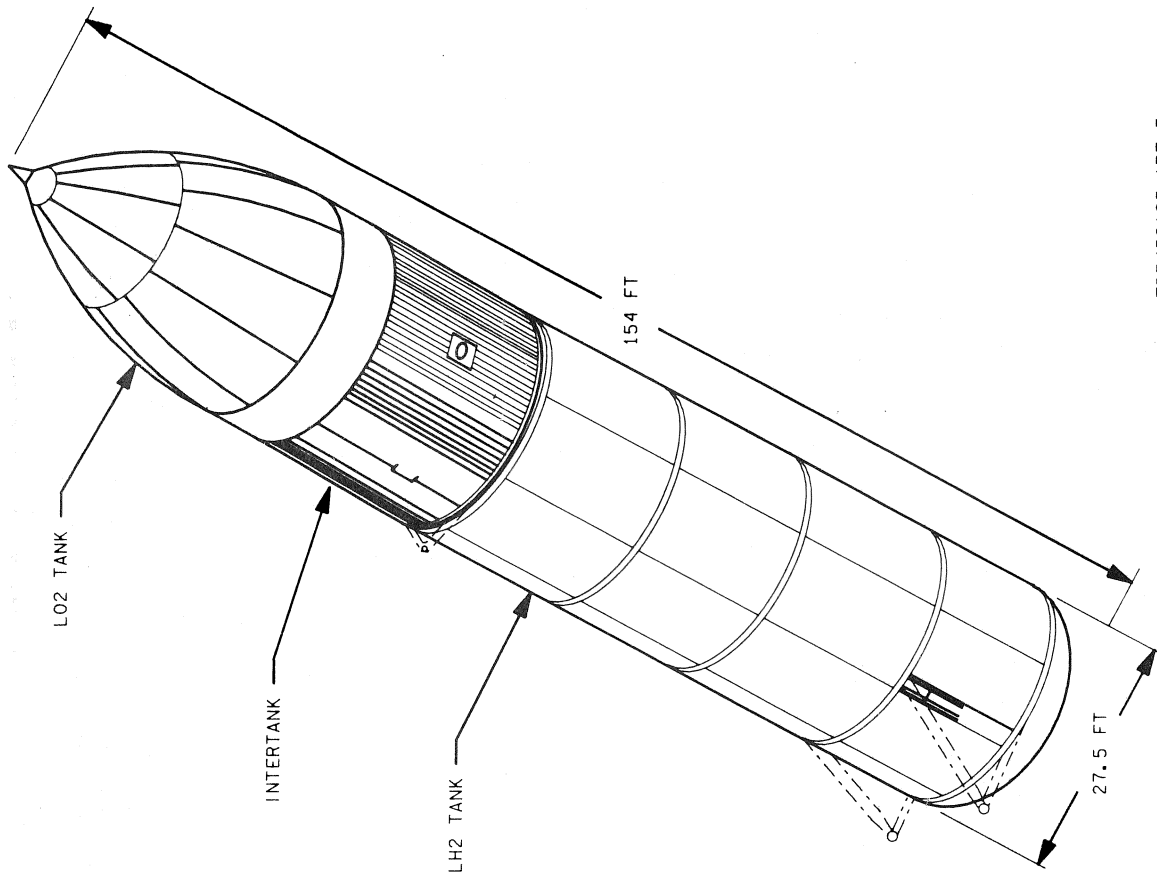

TD3450105. ART, 3

Figure 1-5.— External tank.

The helium system consists of supply tanks, distribution lines, regulators, and valves that accomplish several different functions. It is used for in-flight purges within the engines and provides pressure for actuating engine valves during emergency pneumatic shutdowns. It also supplies helium pressure to actuate the pneumatically operated valves within the propellant management system. During entry, the remaining helium is used for the entry purge and repressurization. Unlike the OMS and reaction control system (RCS), MPS helium is not used to pressurize propellant tanks.

The MPS has critical interfaces with the Orbiter hydraulic system, electrical power system (EPS), master events controller (MEC), and data processing system (DPS). See figure 1-6.

The hydraulic system supplies hydraulic pressure to operate the main engine valves and gimbal actuators.

The EPS furnishes ac power to operate the main engine controllers and dc power to operate the valves and transducers in the propellant management and helium systems.

The master events controller initiates firings of pyrotechnic devices for separating the SRBs from the ET and the ET from the Orbiter. The DPS controls most of the MPS functions with flight software contained in five general purpose computers (GPCs). Up to four of the computers contain redundant sets of primary flight system (BFS). The primary computers control the vehicle unless the BFS is manually engaged.

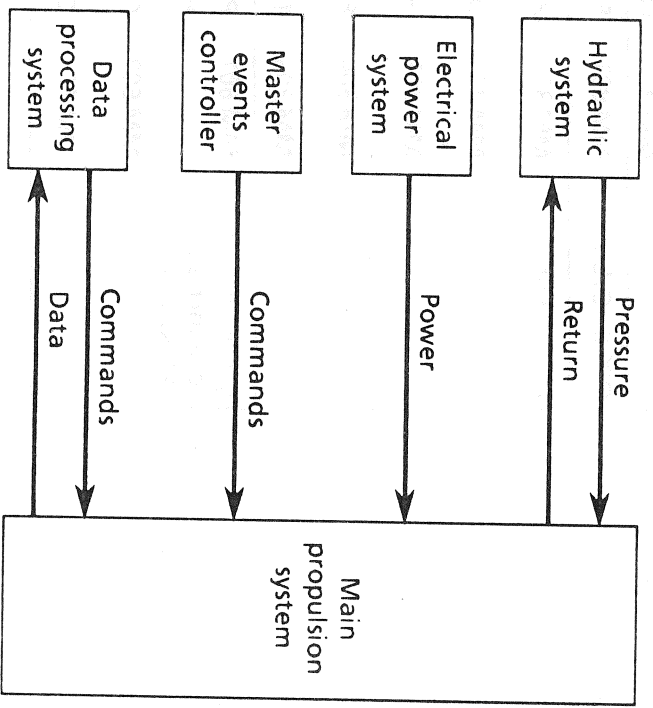

TD345:106*009

Figure 1-6.- Critical interfaces with the MPS.

The Shuttle flight software is divided into operational sequences (OPSs) and major modes (MMs) which correspond to mission phases. It is helpful to be familiar with the mission sequence in terms of OPSs and MMs. Refer to figures 1-7 and 1-8.

The remainder of this manual will cover the MPS in more detail. First, there will be a description of the various components of the system, followed by a description of how the system is operated. The last section provides the background information needed to understand and respond to system malfunctions.

OPS 1: Ascent	MM 101	Prelaunch
	MM 102	First stage of ascent: Lift-off to solid rocket booster (SRB) separation
	MM 103	Second stage of ascent: SRB separation to external tank (ET) separation
	MM 104	Orbital insertion maneuver (OMS 1)
	MM 105	Orbital circularization maneuver (OMS 2)
	MM 106	Post-OMS 2 coast
OPS 2: Orbit	MM 201	Orbit coast
	MM 202	Orbital maneuver
OPS 8: Orbit	MM 801	Flight control system (FCS) checkout
OPS 3: Entry	MM 301	Pre-deorbit coast
	MM 302	Deorbit maneuver
	MM 303	Post-deorbit coast
	MM 304	Early phase of entry
	MM 305	Terminal phase of entry
OPS 6: Return to launch site (RTLS) abort	MM 601	Powered RTLS: RTLS selection to ET separation
	MM 602	Gliding RTLS: Early phase
	MM 603	Gliding RTLS: Terminal phase

TD345:0107*008

Figure 1-7. – Shuttle operational sequences and major modes.

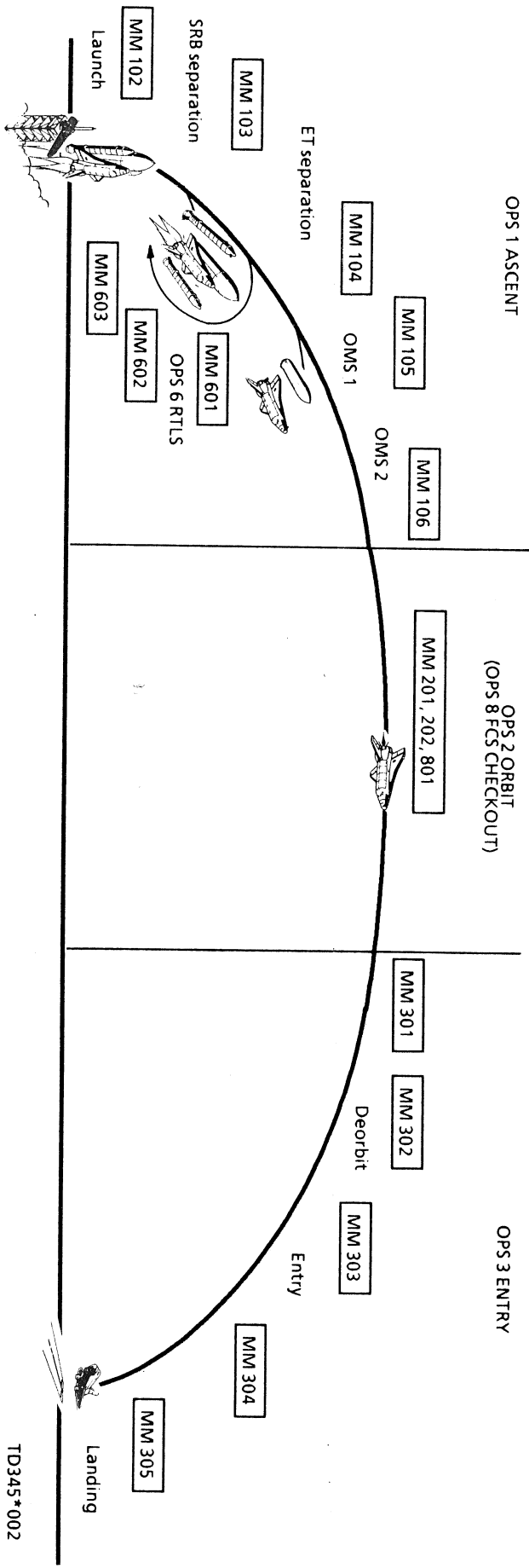

Figure 1-8.—Typical mission profile showing major modes.

This page intentionally left blank.

Section 2: System Description

In this section, the following components of the MPS will be described:

- Space Shuttle main engine
- Main engine controller
- Propellant management system
- Helium system
- External tank
- Thrust vector control.

Space Shuttle Main Engine

The Space Shuttle main engines (SSMEs) are reusable, high performance, liquid propellant rocket engines with variable thrust.

The main engines use LH₂ for fuel and cooling, and LO₂ as an oxidizer. Using a staged combustion cycle, the propellants are partially burned at high pressure and relatively low temperature in the two preburners, then completely burned at high pressure and high temperature in the main combustion chamber. Each engine produces 375 000 lb of sea level thrust and 470 000 lb of vacuum thrust at 100 percent power level. The SSMEs major components and their functions are described as follows. Refer to figure 2-1.

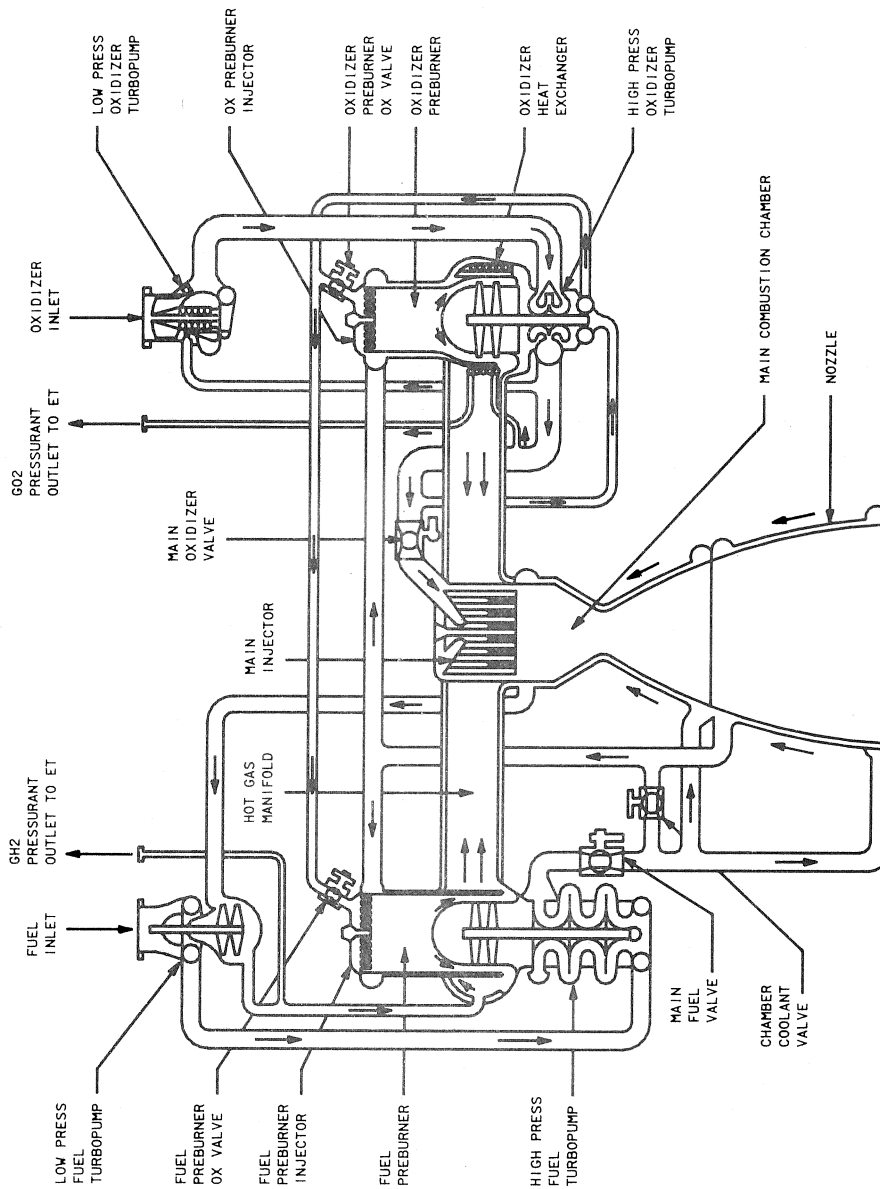

TD3450201-ART.1

Figure 2-1.— Main engine schematic.

Low Pressure Fuel Turbopump

The low pressure fuel turbopump (LPFT) boosts the fuel pressure from its low storage level to the level required at the inlet to the high pressure fuel turbopump (HPFT).

High Pressure Fuel Turbopump

The HPFT boosts the fuel pressure to the engine operating level and supplies hydrogen to the engine fuel and cooling circuits.

Low Pressure Oxidizer Turbopump

The low pressure oxidizer turbopump (LPOT) boosts the oxidizer pressure from its low storage level to the level required at the inlet to the high pressure oxidizer turbopump (HPOT).

High Pressure Oxidizer Turbopump

The HPOT consists of two pumps on a common shaft. The main pump boosts the LO2 pressure and supplies oxidizer to the main combustion chamber, the heat exchanger, the LPOT turbine, and the preburner oxidizer pump. The preburner oxidizer pump boosts the pressure to a higher value which supports the injection of LO2 into the fuel and oxidizer preburners.

Fuel and Oxidizer Preburners

This is where the first stage of the combustion cycle takes place. LH2 and LO2 from the high pressure turbopumps are burned in the fuel preburner (FPB) and oxidizer preburner (OPB) to create a hydrogen-rich gas. The output from the FPB drives the HPFT turbine while the output from the OPB drives the HPOT turbine. Then the hydrogen-rich gas from both turbines exhausts into the hot gas manifold (HGM).

Hot Gas Manifold

The HGM is the structural backbone of the engine. It supports the two preburners, the high pressure turbopumps, and the main combustion chamber (MCC). Hot gas generated by the preburners, after driving the high pressure turbopumps, passes through the HGM on its way to the MCC.

Main Combustion Chamber

Hydrogen-rich gas from the HGM enters the main injector where it is mixed with additional fuel and oxidizer. The mixture is then injected into the MCC for the second, and final, stage of combustion.

Nozzle

The fuel-cooled nozzle is bolted to the MCC and provides a high (77.5:1) thrust chamber expansion ratio.

Oxidizer Heat Exchanger

The oxidizer heat exchanger converts LO2 to gaseous oxygen (GO2) for LO2 tank pressurization and pogo suppression. (Pogo is a cyclical surge and drop in thrust due to feed-line pressure oscillation causing a pogo stick-like ride.) The heat exchanger receives its LO2 from the HPOT main pump.

Valves

There are five propellant valves in each engine. The fuel preburner oxidizer valve (FPOV) and the oxidizer preburner oxidizer valve (OPOV) control the HPFT and HPOT turbine speeds and thus control engine thrust. The main fuel valve (MFV) and main oxidizer valve (MOV) control LH2 and LO2 flow through the engine. The chamber coolant valve (CCV) regulates the amount of LH2 allowed to bypass the cooling ducts, thus controlling engine temperature. The five valves are hydraulically actuated and commanded by the main engine controller. They can also be closed pneumatically using the engine helium supply which provides a backup system for engine shutdown.

Main Engine Fuel Flow

The first place the LH2 goes, upon entering the engine, is the LPFT. See figure 2-2. The LPFT operates at approximately 15 000 rpm and boosts the fuel pressure from 30 to 276 psia. The LPFT discharges directly into the HPFT. The HPFT operates at about 30 000 rpm and boosts the LH2 pressure from 276 to 6515 psia. Discharge from the HPFT passes through the main fuel valve and breaks into three separate paths.

The first path enters the jacket of the MCC where the hydrogen is used to cool the chamber walls. It is then routed to the LPFT where it is used to drive the turbine. Some of the flow from the LPFT is sent through a manifold to the ET to provide LH2 ullage pressure. The rest goes to cool the hot gas manifold and is discharged into the MCC and burned.

The second path goes through the nozzle cooling ducts. It then joins the third path from the CCV and the combined flow is channeled to the fuel and oxidizer preburners for combustion. The resultant hot gas drives the HPFT and HPOT turbines before passing through the hot gas manifold on its way to the MCC for final combustion.

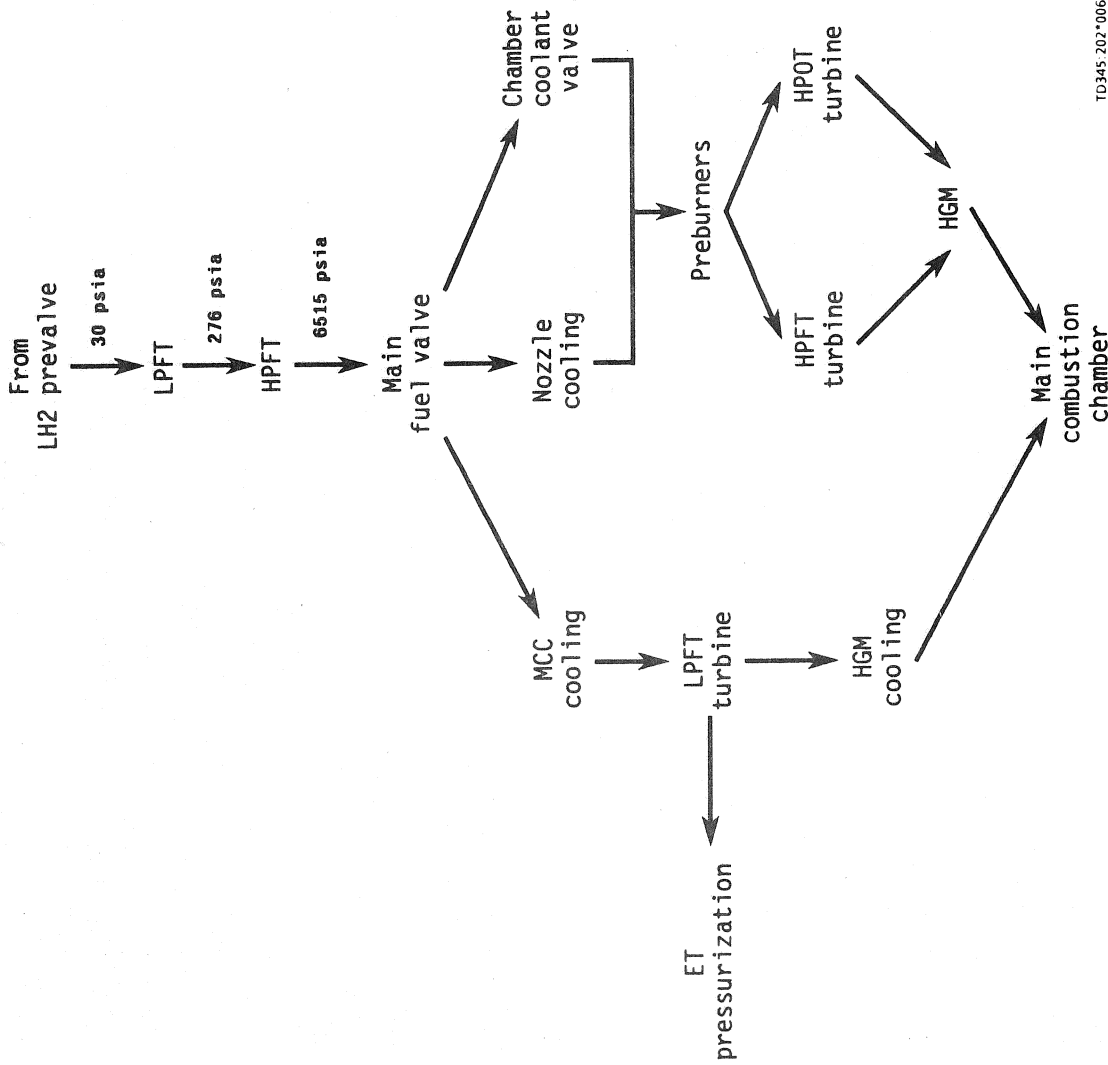

TD345:202*006

Figure 2-2. – Main engine fuel flow.

Main Engine Oxidizer Flow

The LO2 first passes through the LPOT. See figure 2-3. The LPOT operates at approximately 5200 rpm and boosts the oxidizer pressure from 100 to 422 psia. The LPOT discharges directly into the HPOT main pump. The HPOT operates at about 28 000 rpm and the main pump boosts the LO2 pressure from 422 to 4300 psia. Discharge from the HPOT main pump separates into four distinct paths.

The first path returns to drive the LPOT turbine. The second path goes through the oxidizer heat exchanger where the LO2 is converted to GO2 for ET pressurization and pogo suppression. The third path is routed through the MOV and into the MCC.

The fourth, and final, path is directed to the HPOT preburner pump where the LO2 pressure is boosted to 7420 psia and sent to the preburners. There, it is mixed with fuel and burned. The resultant hot gas drives the HPFT and HPOT turbines before passing through the hot gas manifold on its way to the MCC for final combustion.

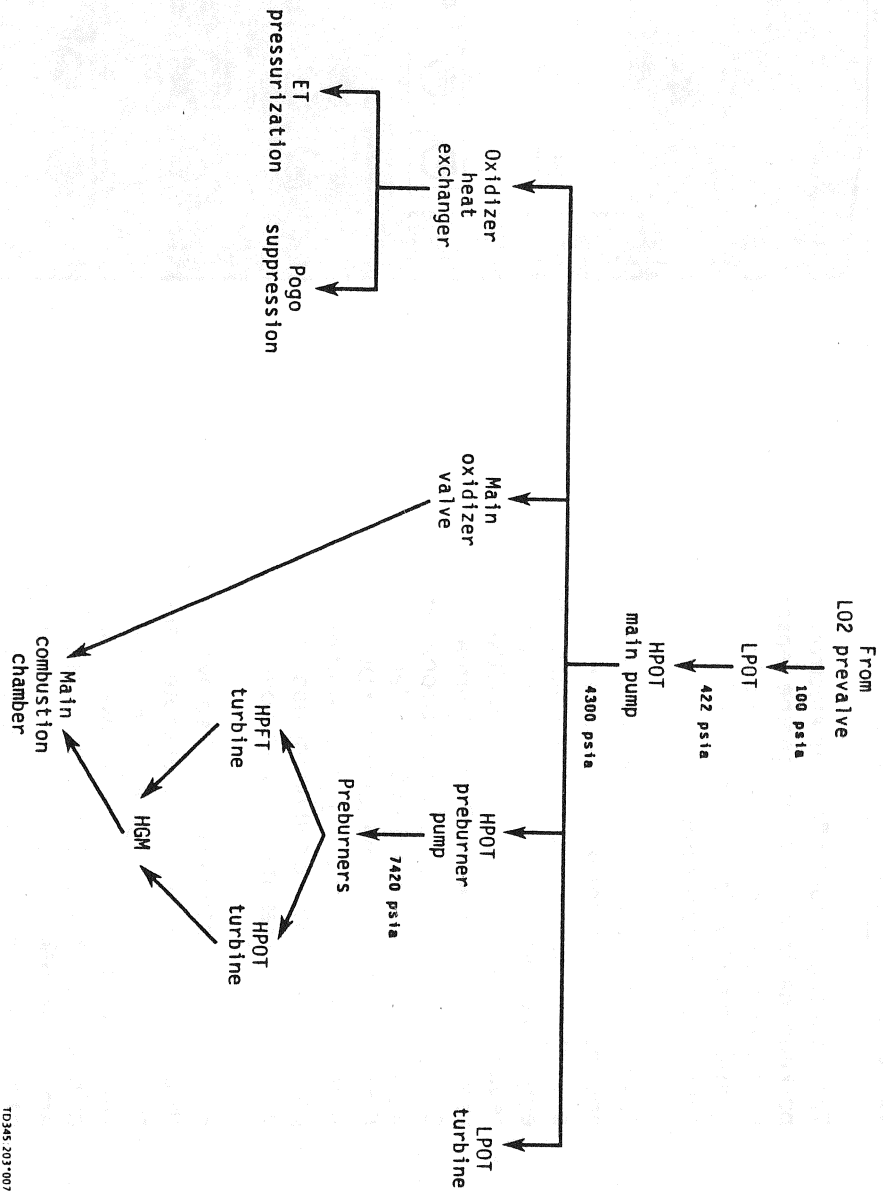

Figure 2-3.- Main engine oxidizer flow.

TD345 203*007

Main Engine Controller

The main engine controller is an electronics package that interfaces with engine sensors, valves, and spark igniters to provide a self-contained system for engine control, checkout, and monitoring.

The tasks of a controller include engine start and shutdown, throttle commands, and propellant mixture control. Mounted on the engine MCC, each controller contains two redundant digital computer units (DCUs) referred to as DCU A and DCU B. Normally, DCU A is in control and DCU B electronics are active, but not in control. If DCU A fails in flight, DCU B will assume control. If DCU B subsequently fails, the engine will shut down pneumatically. While still on the pad, loss of either DCU will result in a launch hold.

Power to the controllers is supplied by the three ac buses in a manner that protects their redundancy. Refer to figure 2-4. Each DCU within a controller receives its power from a different bus. The buses are distributed among the three controllers such that the loss of any two buses will result in the loss of only one engine. The DCUs require all three phases of an ac bus to operate. Power to the controllers is provided through the MIPS ENGINE POWER switches on panel R2. There are two switches for each engine. The top switch is for DCU A, and the bottom switch is for DCU B.

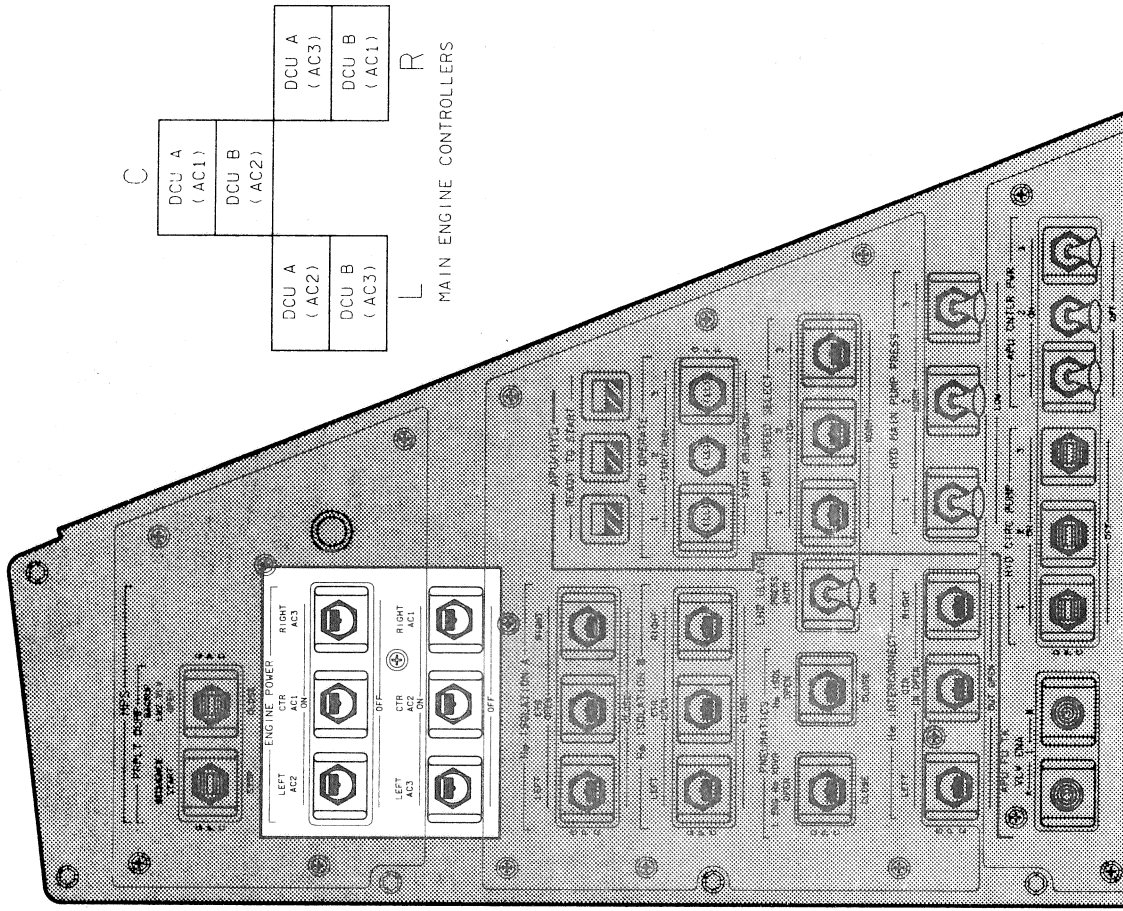

Figure 2-4.— Main engine controller power distribution and crew controls on panel R2.

TD3450004, ART 1E

Each controller receives commands from the GPCs through an engine interface unit (EIU). The EIU is a specialized multiplexer/demultiplexer (MDM) that interfaces the GPCs with the engine controller. Each EIU is dedicated to one SSME and communicates only with that engine controller. The three EIUs have no interface with each other.

Power to the EIUs comes through panel 017. See figure 2-5. If an EIU loses power, its corresponding engine cannot receive any throttle, shut down, or dump commands, and will not be able to communicate with the GPCs. As a result, the controller will maintain the last valid command until it is shut down manually via the ac power switches on panel R2.

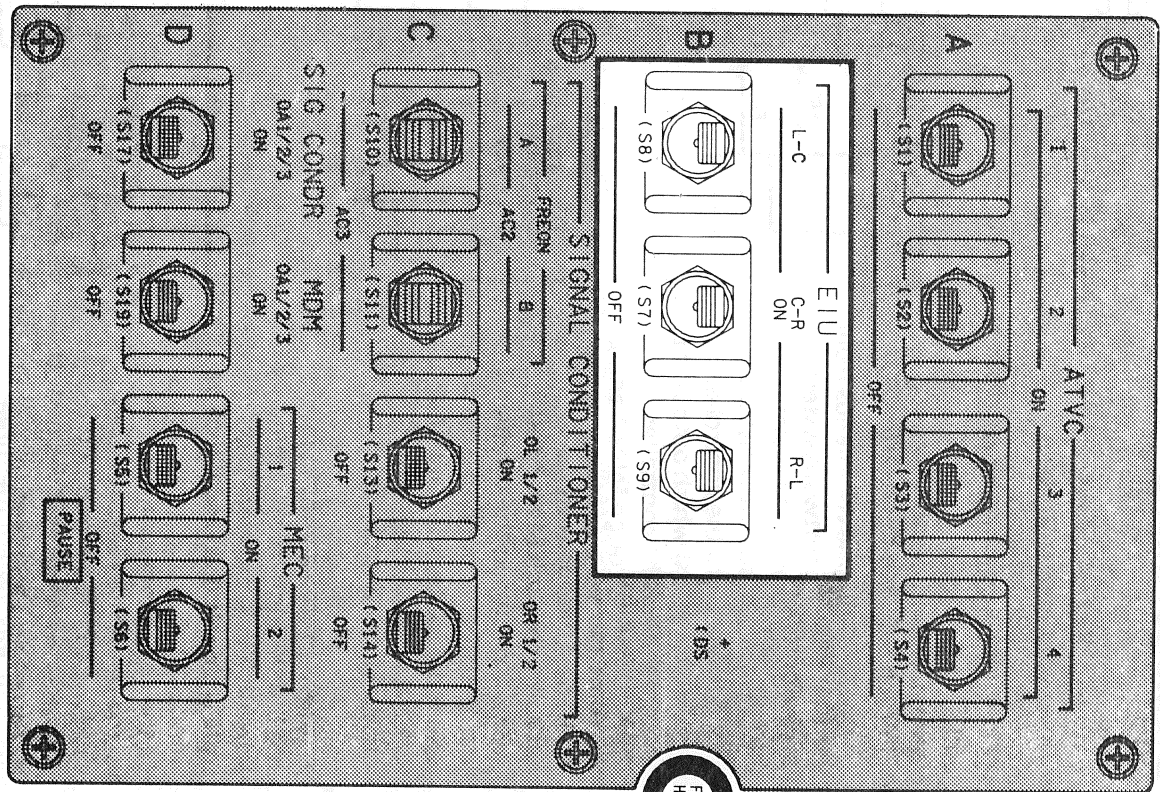

Figure 2-5.—EIU power switches on panel 017.

TD3450205, ART 3

Main Engine Command Flow

Each GPC operating in the redundant set issues main engine commands over its assigned flight-critical (FC) data bus. Normally, GPCs 1, 2, 3, and 4 command buses 5, 6, 7, and 8, respectively. Each FC data bus is connected to one multiplexer interface adapter (MIA) in each EIU. See figure 2-6.

The EIU receives four engine commands from the four primary avionics software system (PASS) GPCs through its four MIAs. After checking the commands for transmission errors, it passes them on to the controller interface assemblies (CIAs) which output the validated commands to the controller. Commands that come through MIAs 1 and 2 are sent to CIAs 1 and 2, respectively. Commands that come through MIAs 3 and 4 are sent to CIA 3 which outputs the command that arrives first; the other command is dead-ended. This is how the EIU reduces four input commands from the GPCs to three output commands to the engine controller.

The controller receives three engine commands from the EIU through three command/data channels in its vehicle interface electronics (VIE). VIE channels A, B, and C receive their inputs from CIA 1, 2, and 3, respectively. The VIE checks the commands again for transmission errors and sends the validated commands to the redundant DCU A and DCU B electronics. The DCU in control (normally DCU A) will vote by comparing for identical commands. If at least two of the three

commands pass voting (i.e., are identical), the controller will issue its own command to accomplish the function. If command voting fails (two or all three commands fail), the controller will reject the GPC command and maintain the last command that passed voting.

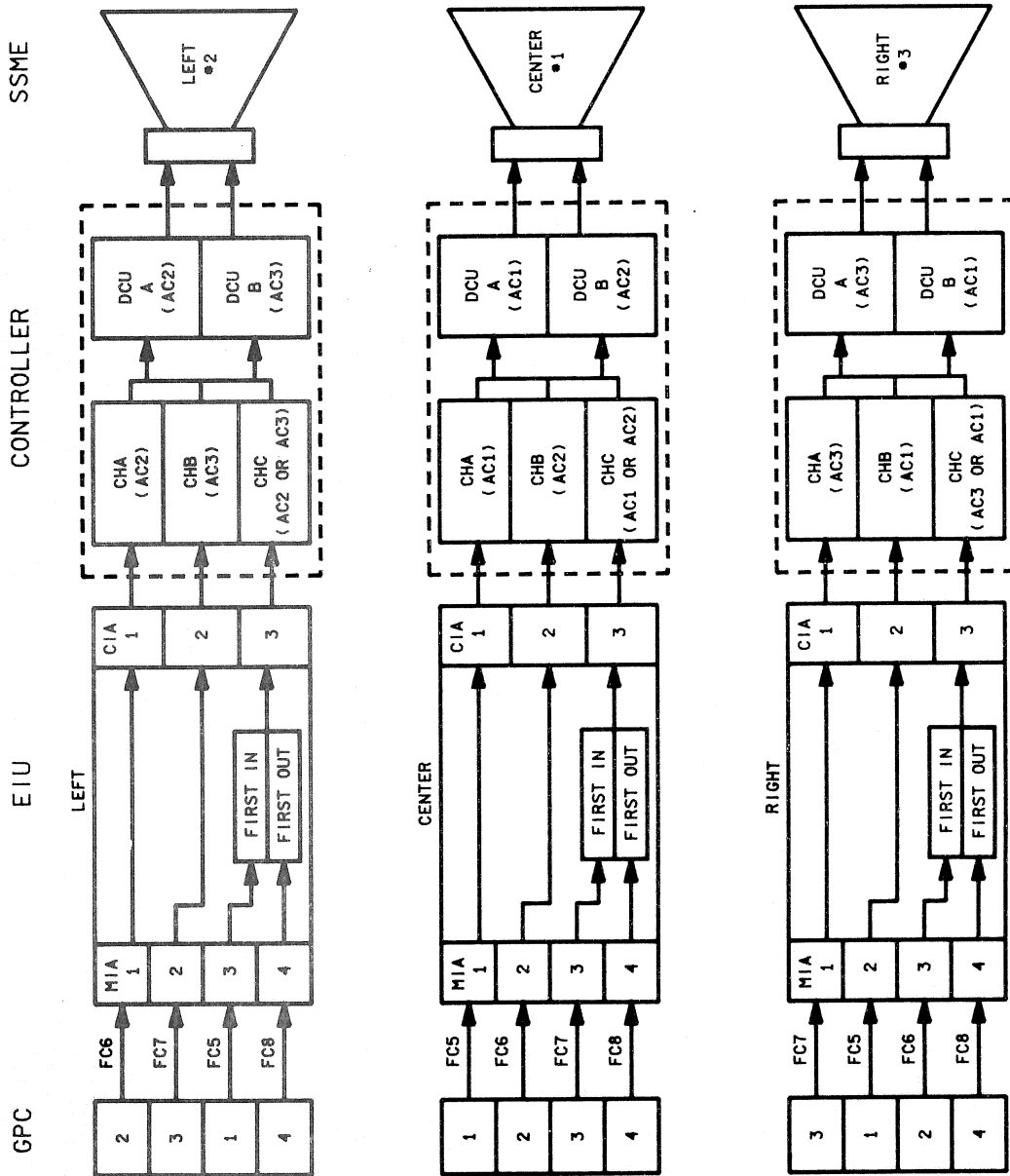

Figure 2-6.—Main engine command flow.

Main Engine Data Flow

Sensors in the engine feed critical data to both controller DCUs. The outputs from DCU A and DCU B are sent to VIE channels A and B for transmission to the EIU. VIE channel C is not used for data. The VIE outputs data over two lines called the primary and secondary data paths. The output from the DCU in control (normally DCU A) is sent over both the primary and secondary data paths. See figure 2-7.

There are two data paths versus three command paths between the engine controller and the EIU. The primary data (from VIE channel A) enters the EIU through CIA 1; secondary data (from VIE channel B) enters through CIA 2. The data are stored in the EIU until the GPCs issue a data request.

The GPCs request both primary and secondary data but, if there are no failures, only primary data is looked at. Primary data is output from the EIU through MIA 1, and secondary data is output through MIA 4. Primary data consists of the first 32 words of the SSME vehicle data table (VDT). Secondary data consists of the first six words of the VDT.

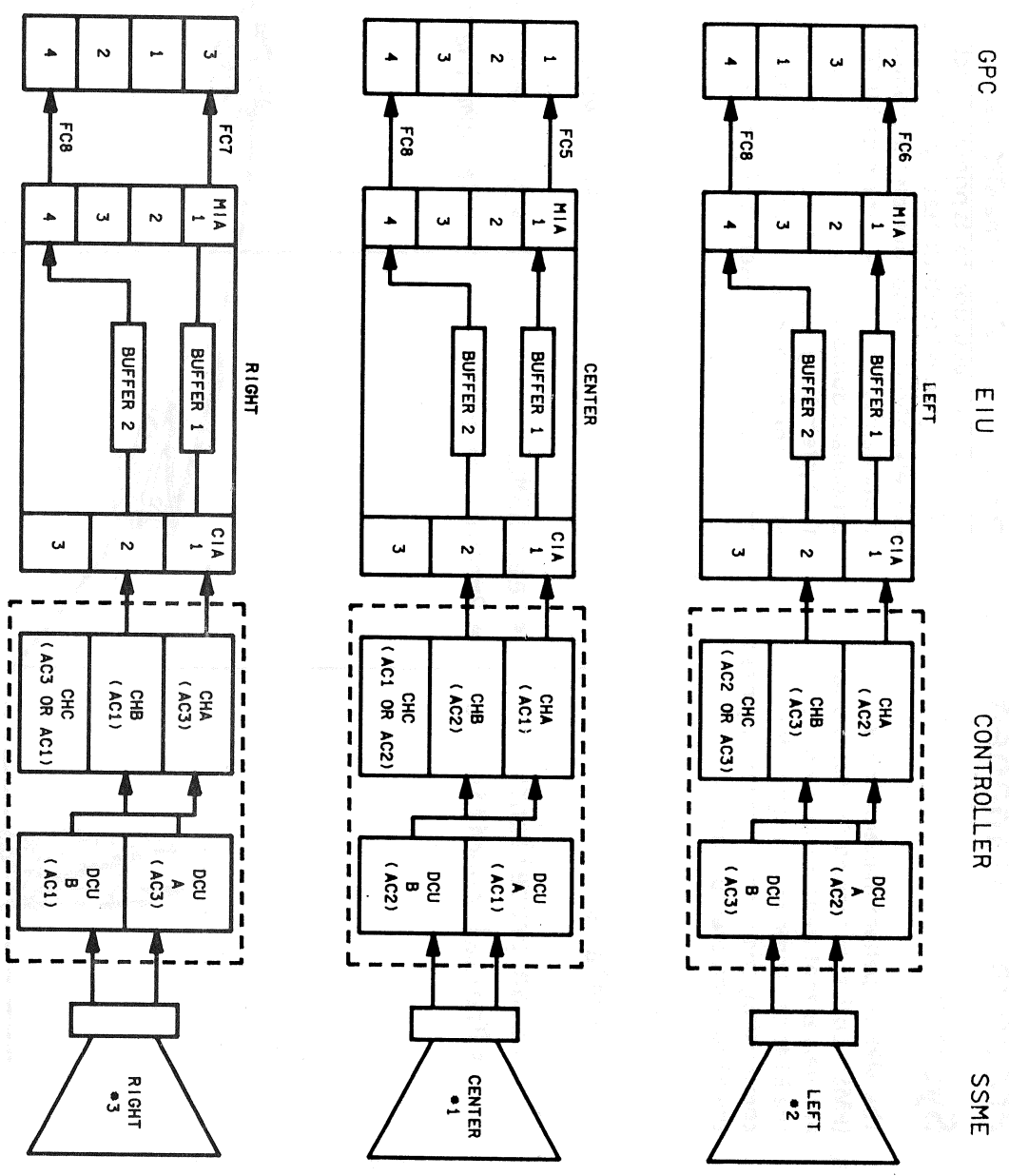

Figure 2-7.- Main engine data flow.

TD3450207, ART, 3

Propellant Management System

The MPS propellant management system (PMS) consists of manifolds, distribution lines, and valves that transport propellants from the ET to the three main engines for combustion, and gases from the engines to the ET for tank pressurization.

The PMS is the lifeline of the MPS. See figure 2-8. In addition to its primary function of feeding propellants to the engines during powered flight, it also controls the loading of propellants before launch, the post-MECO propellant dump and vacuum inerting, and the system purge and repressurization during entry. The major components of the PMS are described as follows. Refer to figure 2-9.

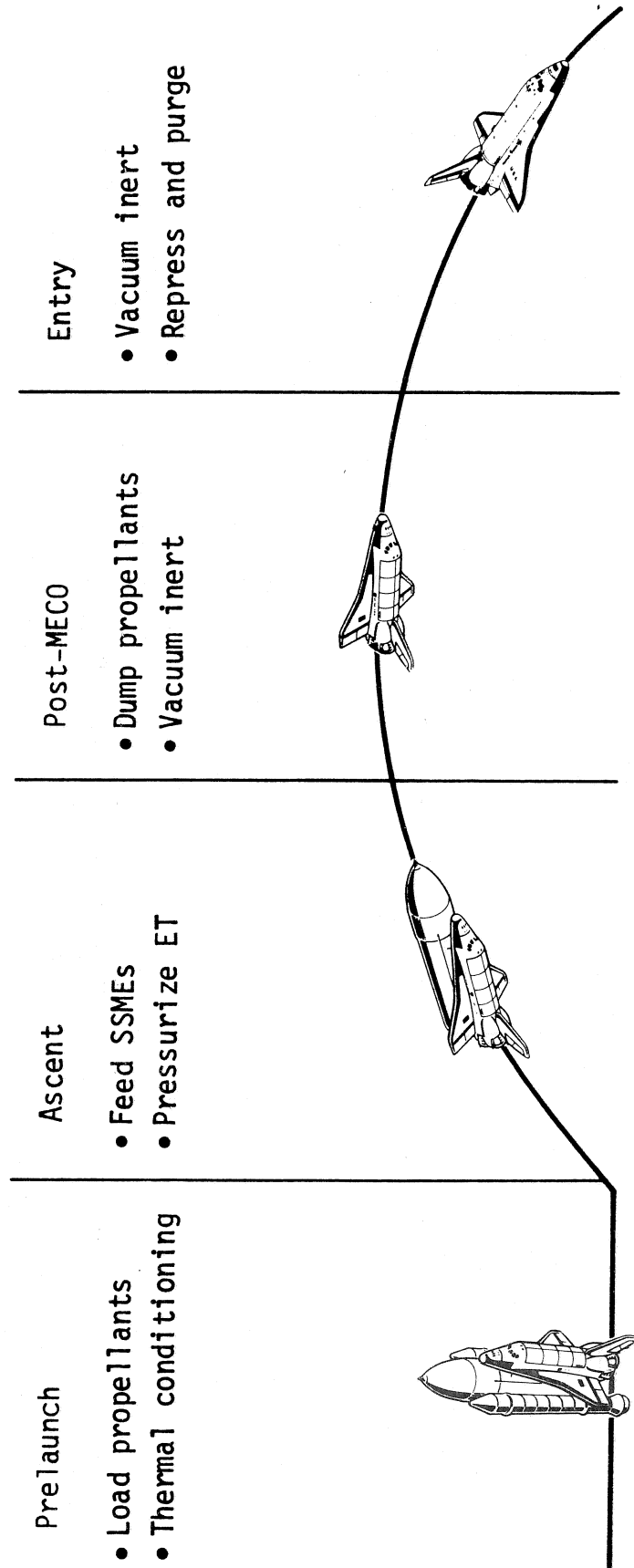
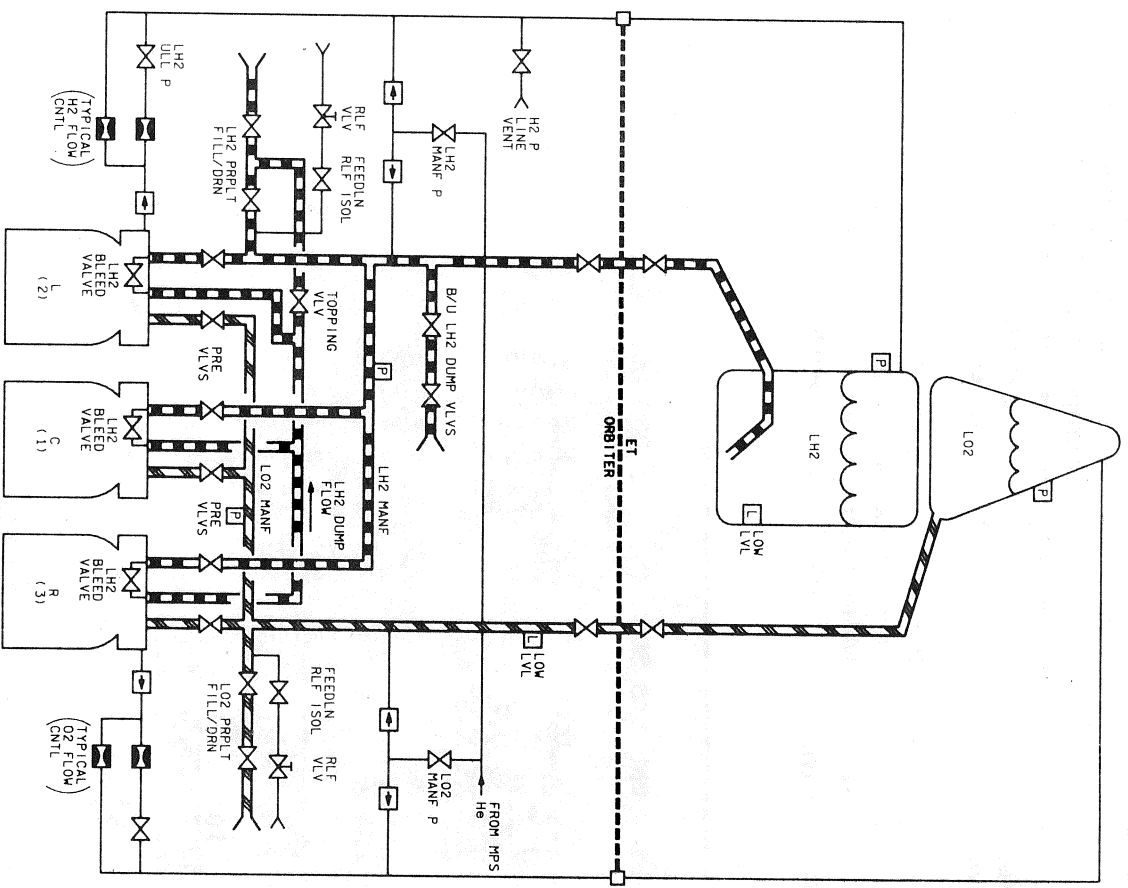

Figure 2-8.— Propellant management system functions.



103450209, ART 4

Figure 2-9. - MPS propellant schematic from the Ascent Pocket Checklist.

Propellant Feedline Manifolds

There are two 17-inch-diameter feedline manifolds in the Orbiter, one for LO2 and one for LH2. Both manifolds have a feedline disconnect valve at one end and two fill/drain valves, one inboard and one outboard, connected in series at the other end. The feedline manifolds connect to the ET at the feedline disconnect valve and to either the ground support equipment (prelaunch only),

or overboard, at the fill/drain valves. The LO2 and LH2 manifolds each have three outlets for the three engine propellant feedlines and one outlet for the feedline relief valve. The LH2 feedline contains one additional outlet for the backup LH2 dump valves.

Pressures within the LO2 and LH2 feedline manifolds can be monitored on the two ENG MANF meters on panel F7 or on the BFS GNC SYS SUMM 1 display. See figure 2-10.

Feedline Disconnect Valves

There are two disconnect valves in each feedline where the Orbiter meets the ET. One of the valves is on the Orbiter side of the manifold, and the other is on the ET side. All four disconnect valves are closed automatically during the ET SEP sequence.

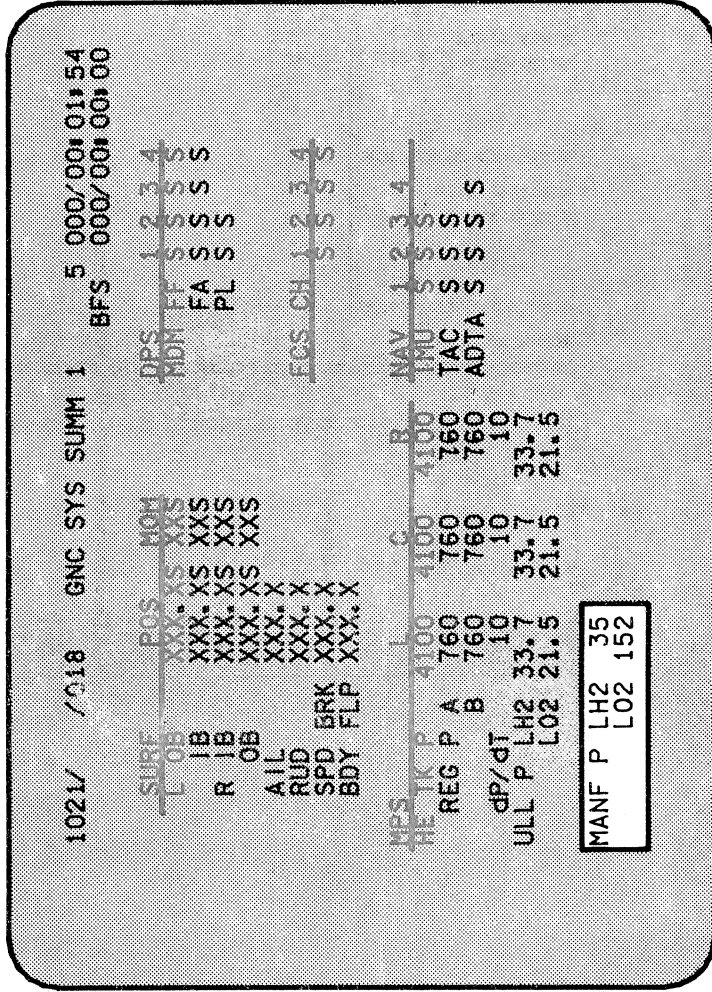
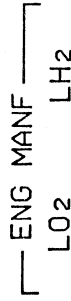
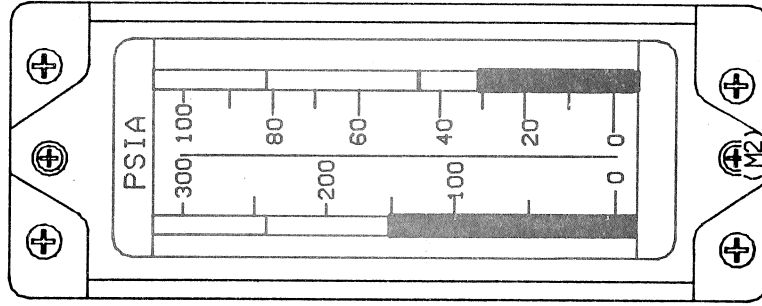

Figure 2-10. - LH2 and LO2 manifold pressures are displayed on the BFS GNC SYS SUMM 1 and the ENG MANF PRESS meters on panel F7.



TD3450210, ART: 5

Fill/Drain Valves

There are two LO2 and two LH2 fill/drain valves, an outboard and an inboard, connected in series. They are used to load the ET before launch and vacuum inert the feedline manifolds in space. Also, the LH2 fill/drains are used to expel any unused fuel during the post-MECO MPS propellant dump. (LO2 is dumped through the engines.) You can control the fill/drain valves manually from panel R4. See figure 2-11.

Manifold Relief Lines

The two relief lines, one for LH2 and one for LO2, connect the feedline manifolds at one end to an overboard port at the other end. Each line contains a relief isolation valve and a relief valve in series. Opening the isolation

valves (which occurs automatically after MECO) allows the relief valve to operate. The relief lines protect the feedline manifolds by allowing excessive pressure to be vented overboard. The relief isolation valves, shown in figure 2-11, can also be controlled from panel R4.

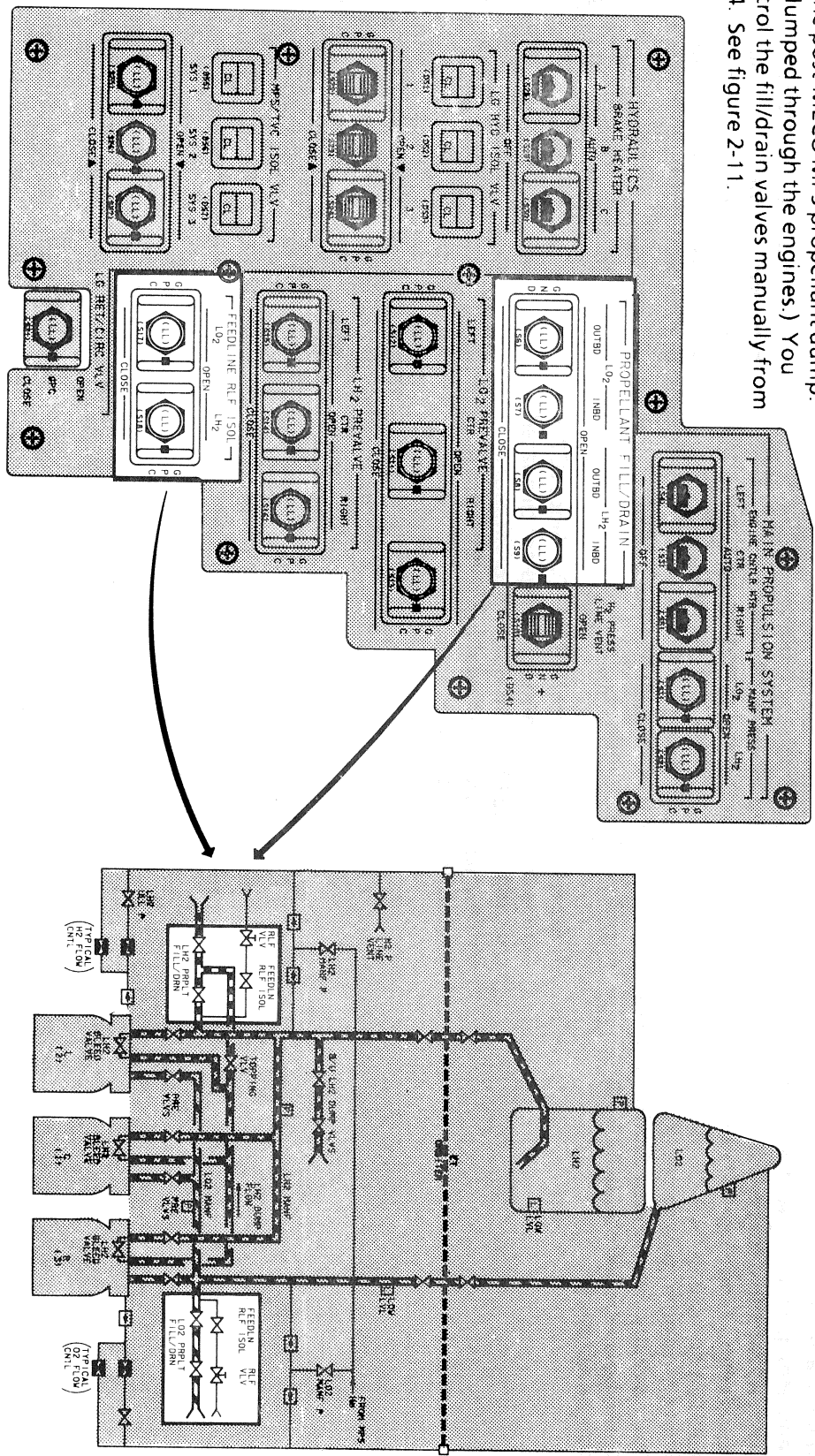

Figure 2-11.— LO2 and LH2 fill/drain and feedline relief isolation valves are controlled from panel R4.

703450211, ART. 5

Backup LH2 Dump Valves

The backup LH2 dump line connects the LH2 feedline manifold to an overboard port above the left wing of the Orbiter. See figure 2-12. The line, designed primarily for the post-MECO LH2 dump during a return to launch site (RTLS) abort, is also used to vent the LH2 manifold after a nominal MECO. Since LH2 evaporates quickly, this vent is accomplished to prevent LH2 manifold pressure buildups from repeatedly cycling the relief valve before the propellant dump begins. Flow through the line is controlled by two valves in series which are normally commanded by the GPCs but can also be controlled manually from panel R2 during OPS 1.

Topping Valve

This valve controls the flow of LH2 through the tank topping manifold which is used for prelaunch LH2 tank topping and thermal conditioning. During thermal conditioning, propellants flow through the engine components to cool them for engine start.

LH2 is loaded through the outboard fill/drain valve, circulates through the topping valve to the engines for thermal conditioning, and is pumped into the ET for tank topping. (The part of the topping recirculation line that goes to the ET is not shown on the pocket checklist schematic.)

There is no topping valve for LO2. Since LO2 is harmless in the atmosphere, it is not circulated back to the ET during thermal conditioning. Rather, it is dumped overboard through the engine LO2 bleed valves.

LH2 and LO2 Bleed Valves

The three LH2 bleed valves, one in each engine, connect the engine internal LH2 lines with the topping valve manifold. They are used to route LH2 through the engines during prelaunch thermal conditioning and to dump the LH2 trapped in the engines post-MECO.

There are also three LO2 bleed valves that are not shown on the pocket checklist schematic. They connect the engine internal LO2 lines to an overboard port and are used only during prelaunch thermal conditioning.

Prevalves

The six engine prevalves control the flow of LH2 and LO2 to the three main engines. Most of the pre valve functions are automatic, but they can also be controlled manually from panel R4. See figure 2-13.

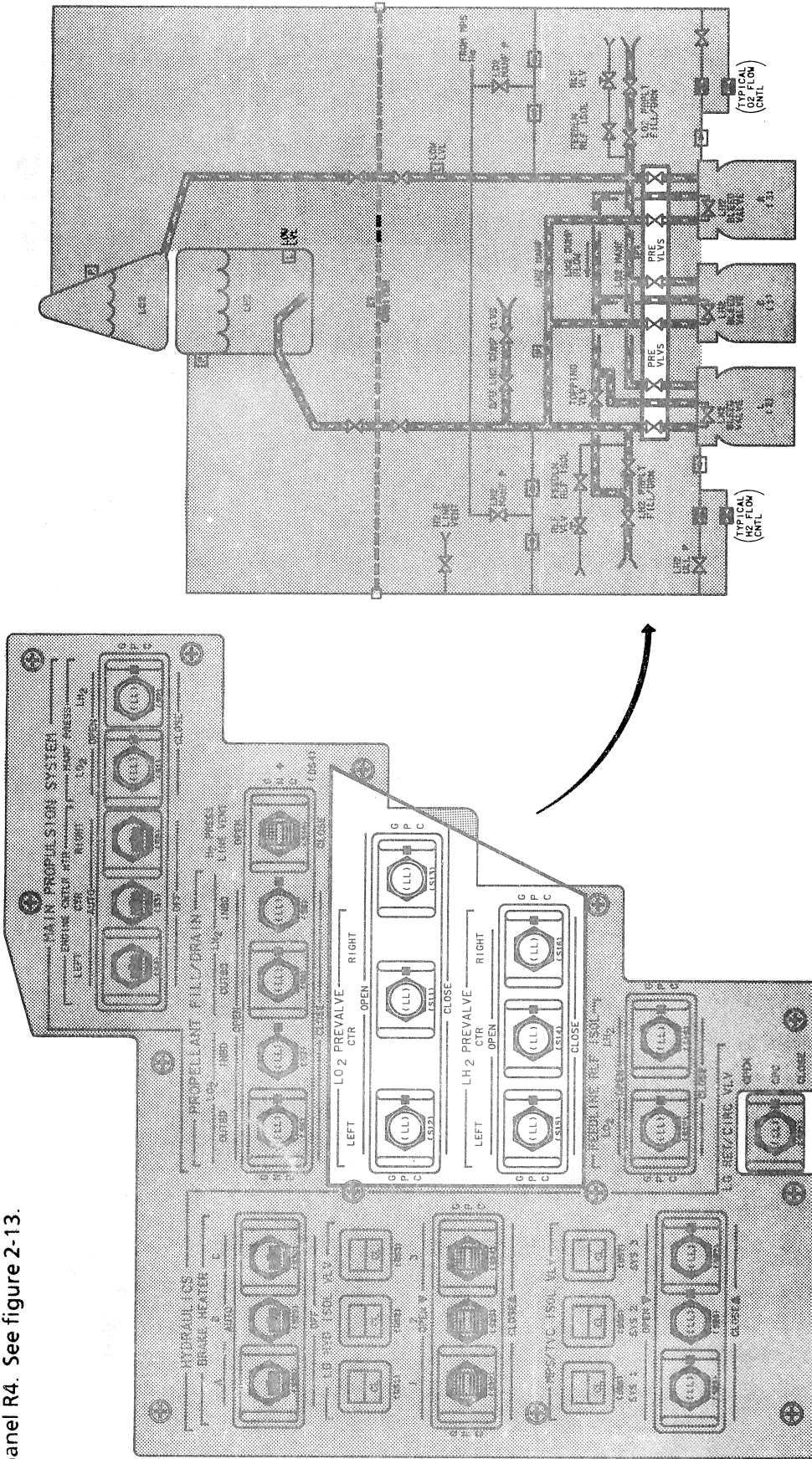

Figure 2-13. – LO2 and LH2 pre valve switches are on panel R4.

Ullage Pressure System

Ullage refers to the space in each tank not occupied by the propellants. The ullage pressure system consists of the sensors, lines, and valves used to collect gaseous propellants (GH2 and GO2) from the three main engines and supply them to the ET to maintain propellant tank pressure during engine operation. Refer to figure 2-14.

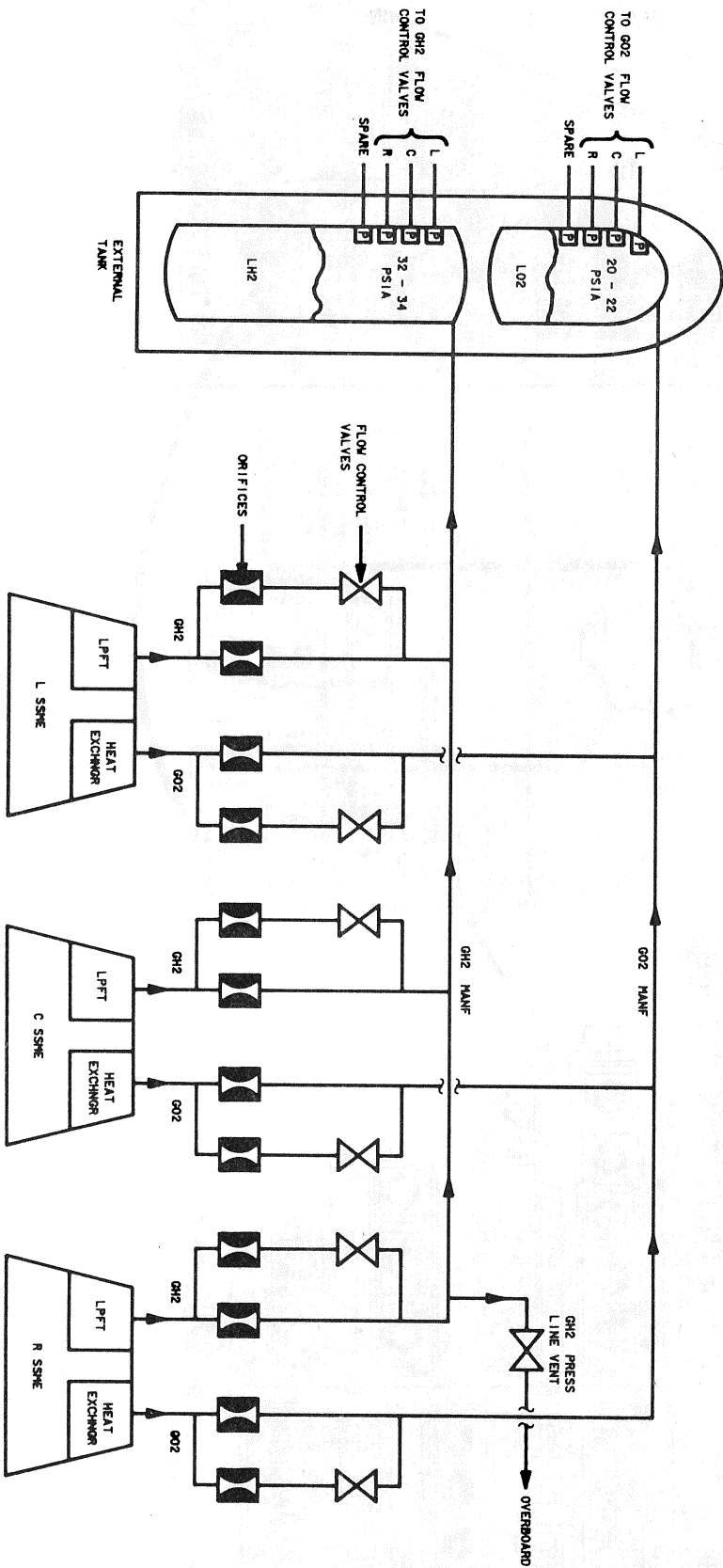

Figure 2-14. – External tank ullage pressure system.

TD3490214, ART 3

There are two ET pressurization manifolds in the Orbiter, one for GH2 and one for GO2. Each manifold connects its respective propellant tank at one end to the three engine ullage pressure outlet lines at the other end.

There are six engine ullage pressure outlet lines in the Orbiter, three for GH2 and three for GO2. Each GH2 line connects the LPFT turbine outlet on one SSME to the GH2 ET

pressurization manifold. Each GO2 line connects the oxidizer heat exchanger outlet on one SSME to the LO2 ET pressurization manifold.

Each of the six engine ullage pressure outlet lines contains two orifices connected in parallel, and one flow control valve connected in series with one of the orifices. The combination of orifices and flow control valves is used to control the ullage pressure in the two ET propellant tanks.

Pressure in the LH2 tank is maintained between 32 and 34 psia, and LO2 tank pressure is maintained between 20 and 22 psia. Each flow control valve is driven by its own ullage pressure sensor at the top of its corresponding propellant tank. When a sensor detects low pressure, its

corresponding flow control valve opens; when the pressure comes back up, the valve is closed. The three GH2 flow control valves can also be opened manually with the LH2 ULLAGE PRESS switch on panel R2. See figure 2-15. The three LH2 and three LO2 ullage pressure sensor outputs can be read on the BFS GNC SYS SUMM 1 display (figure 2-16).

A GH2 pressurization vent line connects the ET GH2 pressurization manifold to an overboard port. Flow through the line is governed by the GH2 pressurization line vent valve which is controlled from panel R4. This line is used exclusively for vacuum inerting the GH2 pressurization manifold onorbit. See figure 2-15.

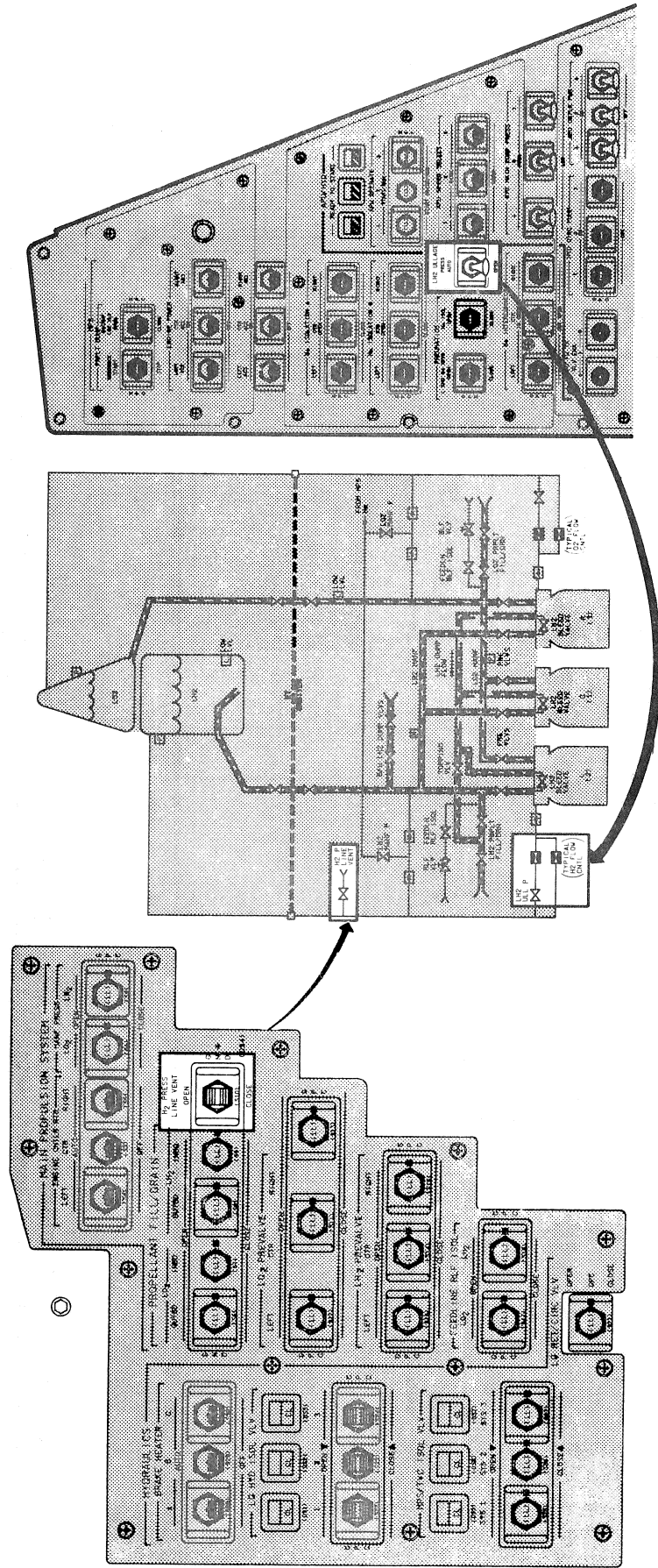

TD1450215, ART1, 4

Figure 2-15. – Crew controls for the ullage pressure system include the H2 PRESS LINE VENT switch on panel R4 (left) and the LH2 ULLAGE PRESS switch on panel R2 (right).

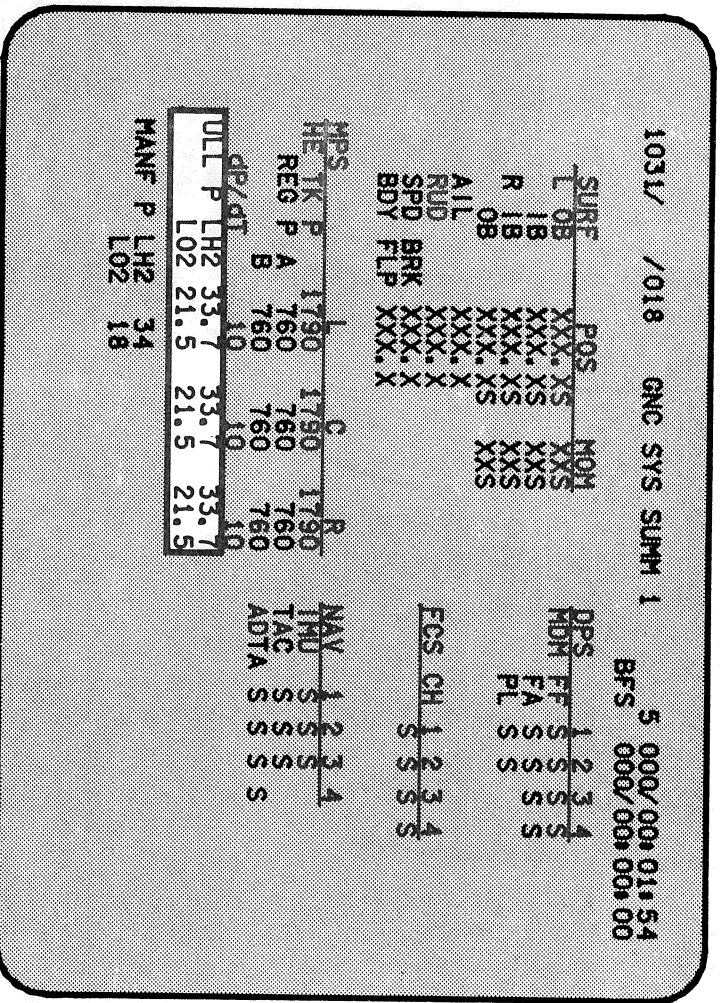

Figure 2-16 - LH2 and LO2 ullage pressures are displayed on the BFS GNC SYS SUMM 1.

Manifold Pressure Valves

The LH2 and LO2 manifold pressure valves route helium from the MPS helium system into the feedline manifolds. This helium is used for pressure to expel propellants during the MPS propellant dump and to repressurize the propellant lines during entry. They can be controlled manually from panel R4. See figure 2-17.

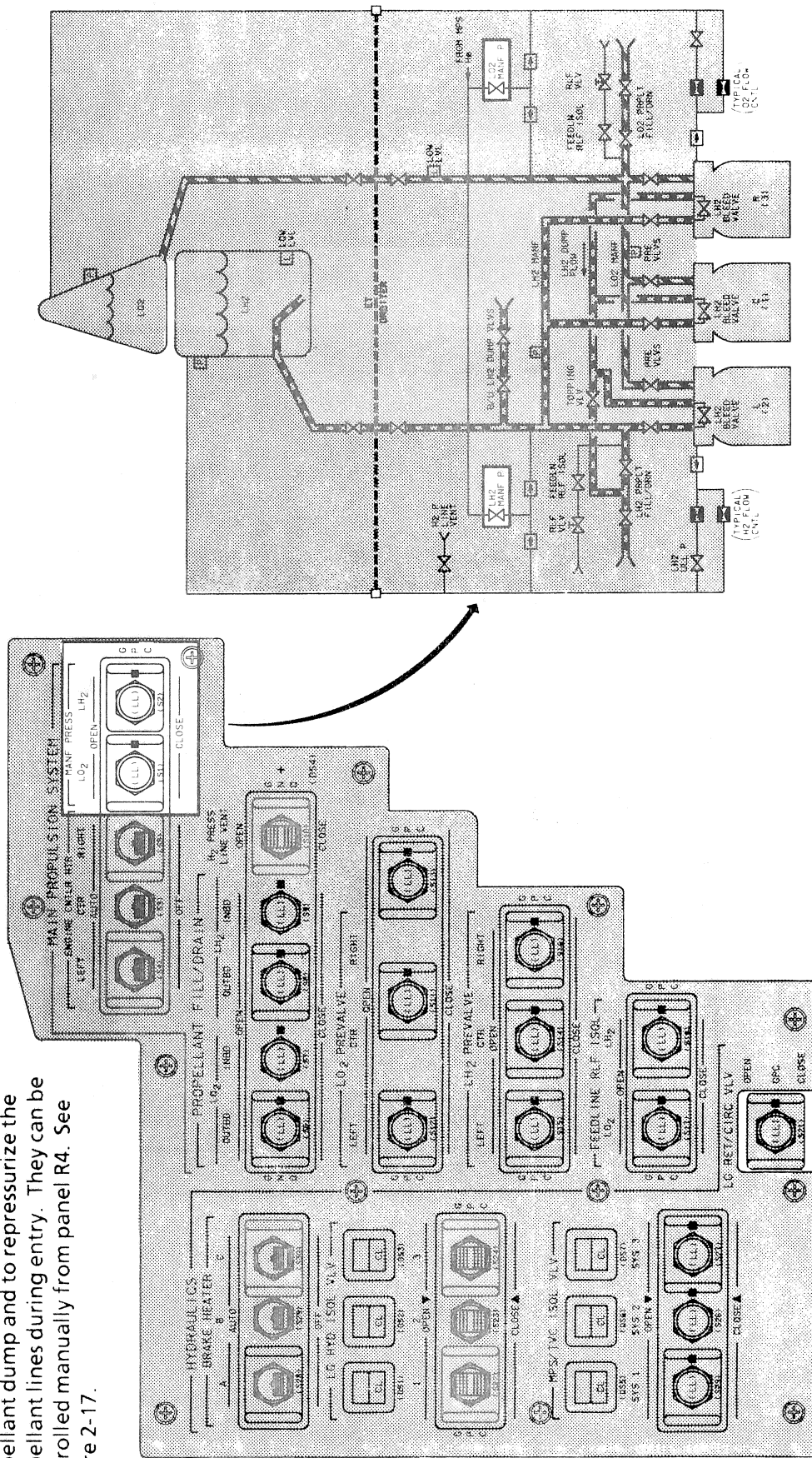

Figure 2-17.--LO2 and LH2 MANF PRESS switches on panel R4.

Valve Types

The PMS uses two basic types of valves: pneumatically actuated and electrically actuated. Refer to figure 2-18. Pneumatic valves are used where large loads are encountered, such as in the control of liquid propellant flows. Electrical valves are used for lighter loads, such as in the control of gaseous propellant flows.

The pneumatically activated valves are divided into two subtypes: those that require pneumatic pressure to open and close the valve (type 1) and those that are spring-loaded to one position and require pneumatic pressure to move to the other position (type 2).

The electrically-actuated solenoid valves are spring-loaded to one position and move to the other position when electrical power is applied.

PMS VALVE TYPES

Pneumatic		Electric
Type 1	Type 2	
Feedline disconnect valves Fill/drain valves Prevalves	Feedline relief isolation valves (NO) Backup LH2 dump valves (NC) Topping valve (NC)	Ullage pressure flow control valves (NO) GH2 press line vent (NC) Manifold pressure valves (NC)

NO: Normally open - The spring force drives the valve open.
 NC: Normally closed - The spring force drives the valve closed.

Figure 2-18.- Valve types in the propellant management system.

Helium System

The MPS helium system consists of storage tanks, distribution lines, regulators, and valves that supply helium to the main engines and the MPS PMS.

Helium is supplied to the main engines to purge the HPOT intermediate seals and also to close the engine valves during an emergency pneumatic shutdown. The balance of MPS helium is used to operate the pneumatic valves within the PMS, to help force LH2 and LO2 out of the propellant lines during the post-MECO dump, and to pressurize or purge the lines during entry. The helium system is divided into four distinct subsystems, one for each of the three main engines and a fourth pneumatic system to operate the propellant valves. The major components of the system are described as follows. Refer to figure 2-19.

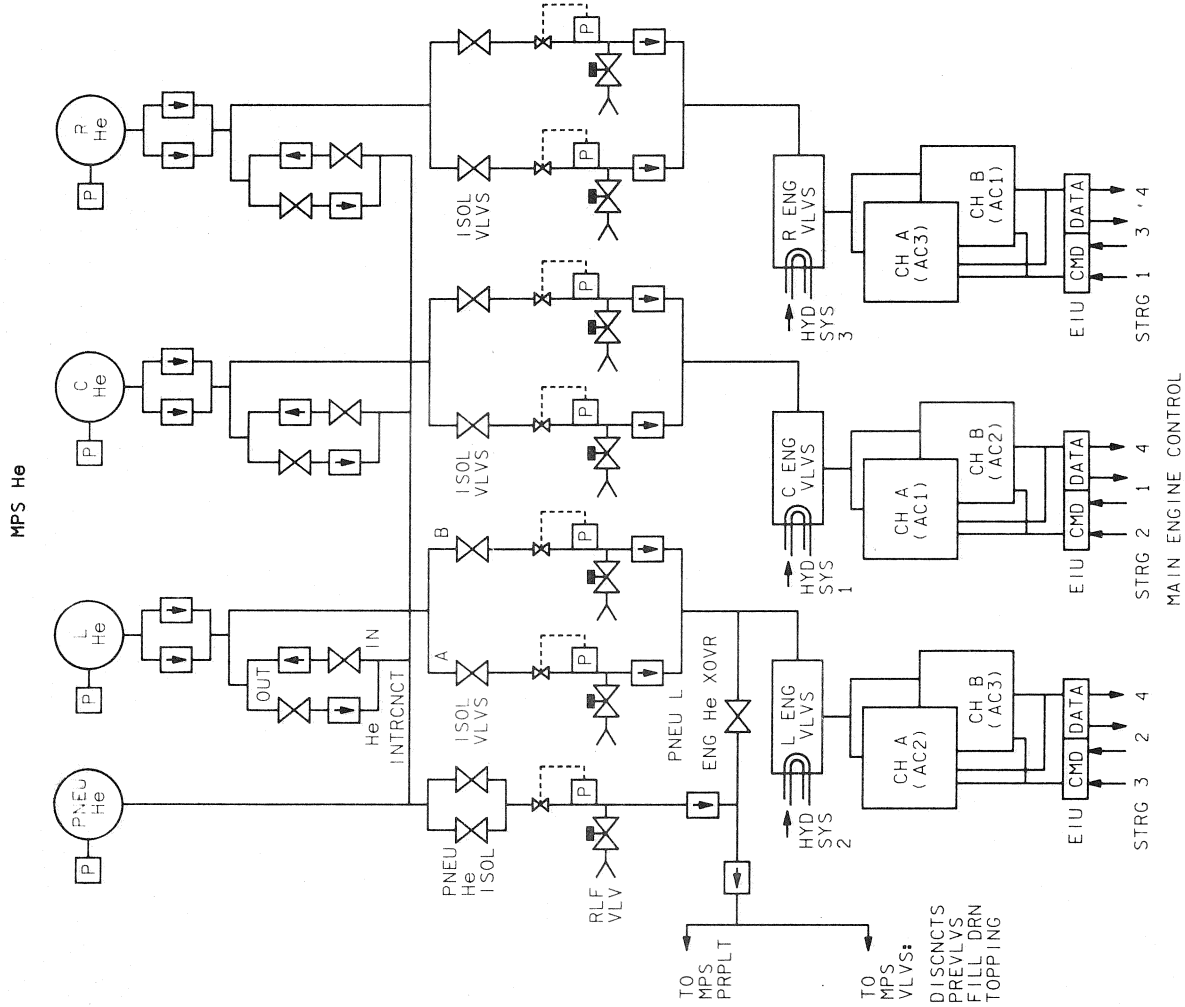

TD3450219, ART, 3

Figure 2-19. – MPS helium schematic from the Ascent Pocket Checklist.

Supply Tanks

There are three large (17.3 cubic-foot) and seven small (4.7 cubic-foot) helium tanks. Each large tank is plumbed to two of the small tanks to form three clusters. Each cluster (shown in the pocket checklist schematic as one tank) provides helium to one of the main engines. The remaining small tank is the pneumatic helium supply.

The crew can monitor engine helium tank pressures on the MPS HELIUM meters on panel F7 or on the BFS GNC SYS SUMM 1 display. Pneumatic helium tank pressure can be monitored only on panel F7. See figure 2-20.

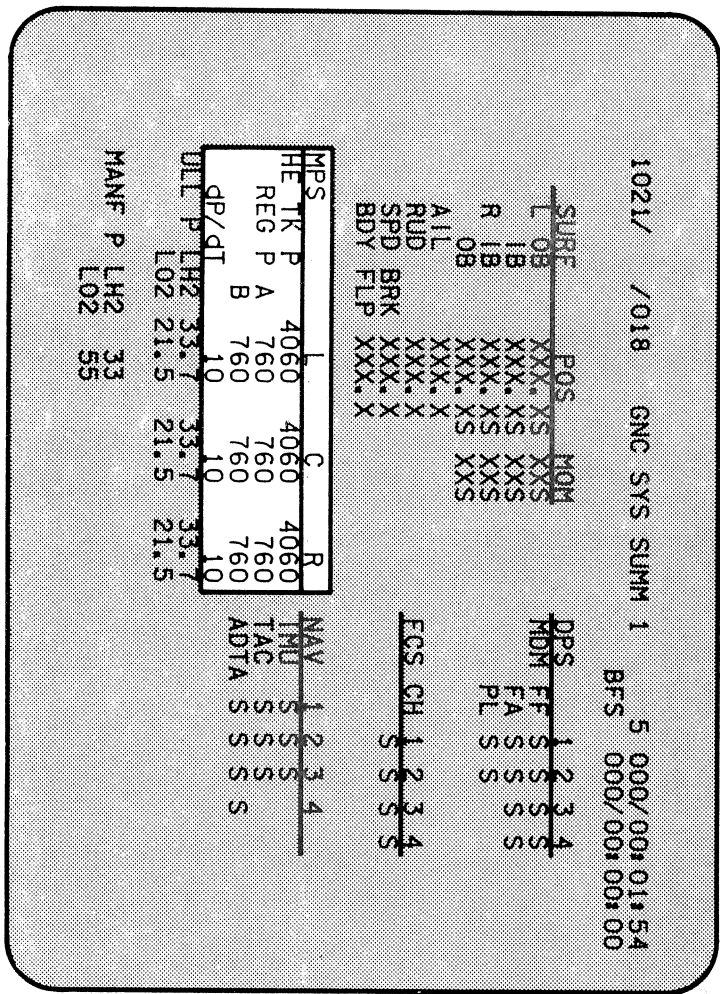
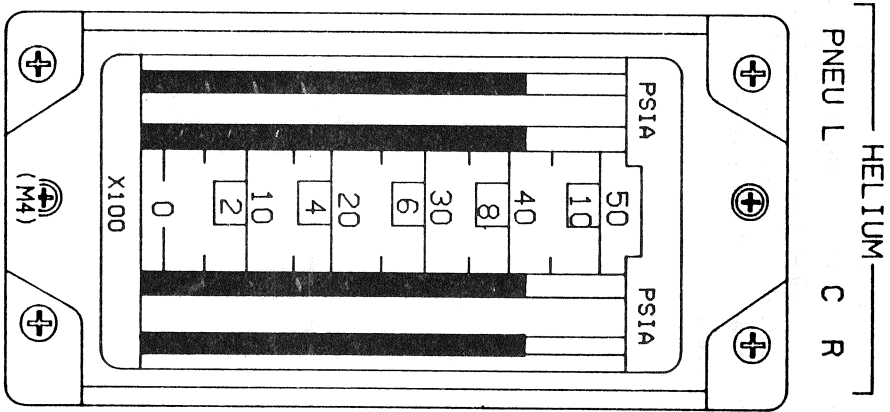

Figure 2-20. MPS helium tank and regulator pressures are displayed on the BFS GNC SYS SUMM 1 and the MPS HELIUM meters on panel F7.



TD3450220. ART 1 5

Helium Isolation Valves

There are eight helium isolation valves, grouped in pairs, that control the flow of helium from the supply tanks. One pair is connected to each engine tank cluster, and the fourth pair is connected to the pneumatic supply tank. In the engine helium supply systems, the isolation valves are in parallel with each valve controlling helium flow through one leg of a dual redundant supply circuit. Each leg, referred to as leg A and leg B, contains an isolation valve, a regulator, a relief valve, and a check valve.

The two isolation valves for the pneumatic supply tank are also connected in parallel, but the rest of the pneumatic system consists of a single regulator, relief valve, and check valve.

Each of the engine helium isolation valves can be controlled by its own switch on panel R2. See figure 2-21. Both pneumatic helium isolation valves are controlled by a single switch, also on panel R2. The six engine system regulator pressures can be read on the BFS GNC SYS SUMM 1 display. The three engine system leg A regulators and the pneumatic system regulator can be monitored on the MPS HELIUM meters on panel F7 (figure 2-20).

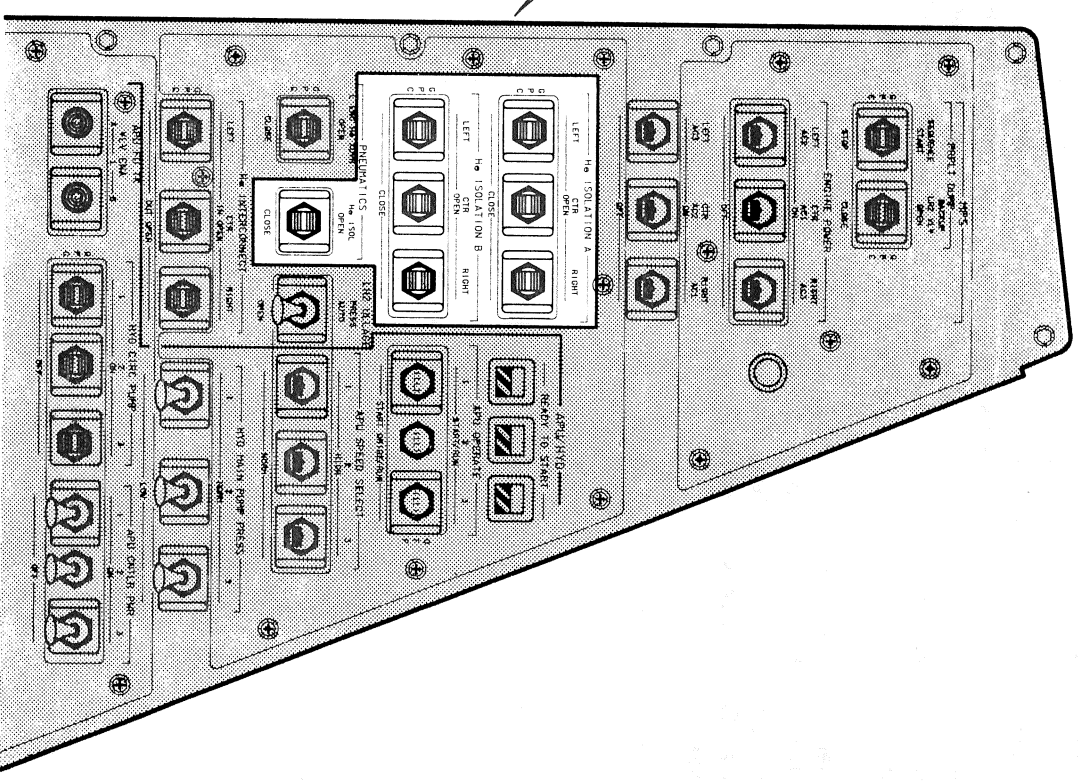
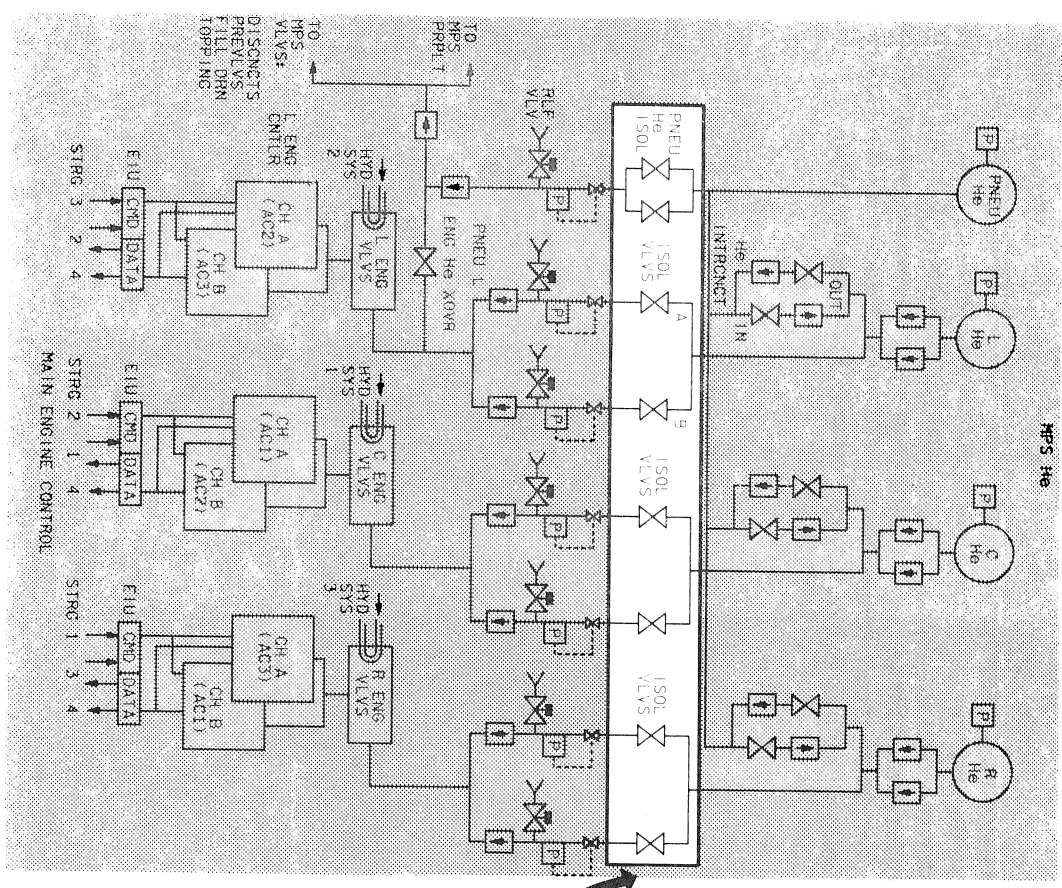

Figure 2-21. -- The MPS helium isolation valves are controlled from panel R2.

Pneumatic Left Engine Helium Crossover Valve

The crossover valve between the pneumatic and left engine helium systems serves as a backup for the nonredundant pneumatic pressure regulator system. In the event of a pneumatic helium regulator failure or leak in the pneumatic helium system, the left engine helium system can provide regulated helium through the crossover valve to the pneumatic helium distribution system. The PNEU L ENG He XOVER valve is controlled from panel R2. See figure 2-22.

Helium Interconnect Valves

Each of the three engine helium supply systems has a helium "out" interconnect valve which connects it to the pneumatic supply system. Also, each has a helium "in" interconnect valve which connects the pneumatic helium supply system to that engine supply system. Each valve is connected in series with a check valve which allows flow in only one direction.

Each pair of interconnect valves is controlled by a single switch on panel R2 (figure 2-22). The three positions on each switch are IN OPEN, GPC, and OUT OPEN. When the switch is in the IN OPEN position, the "in" interconnect valve is open and the "out" interconnect valve is closed. The OUT OPEN position does the reverse. When the switch is in GPC, both valves are closed except when commanded open by the GPCs.

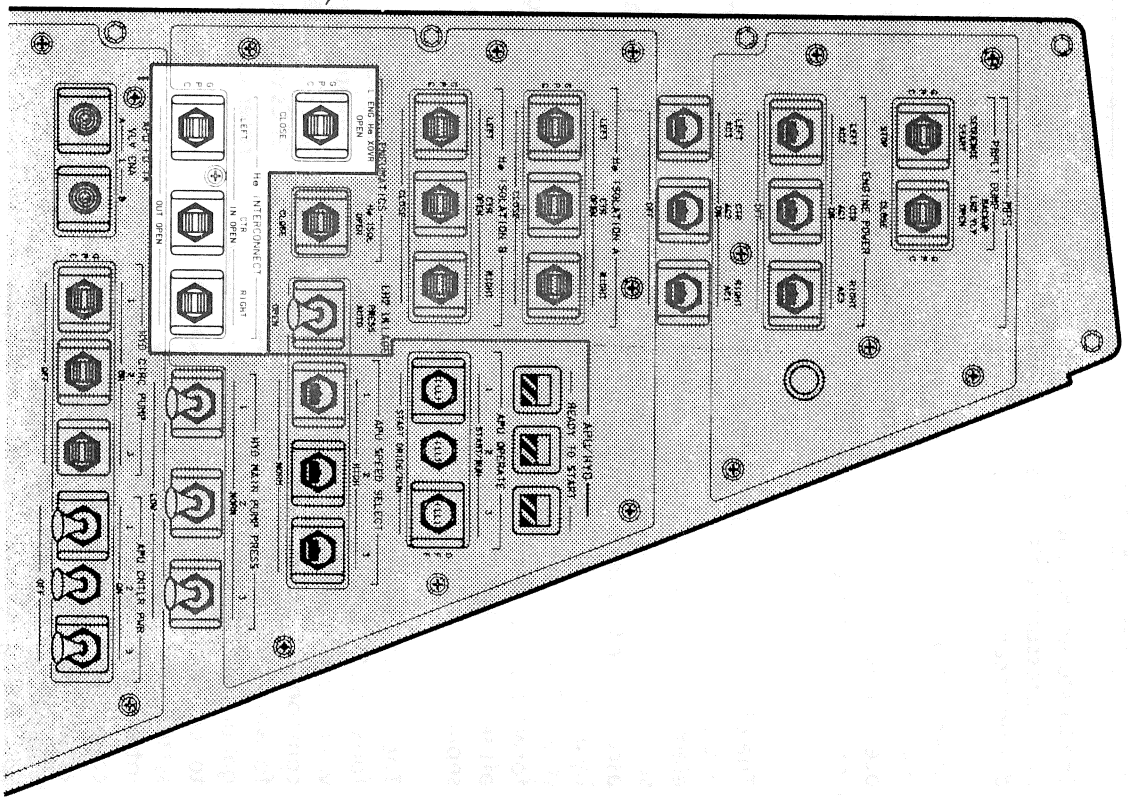
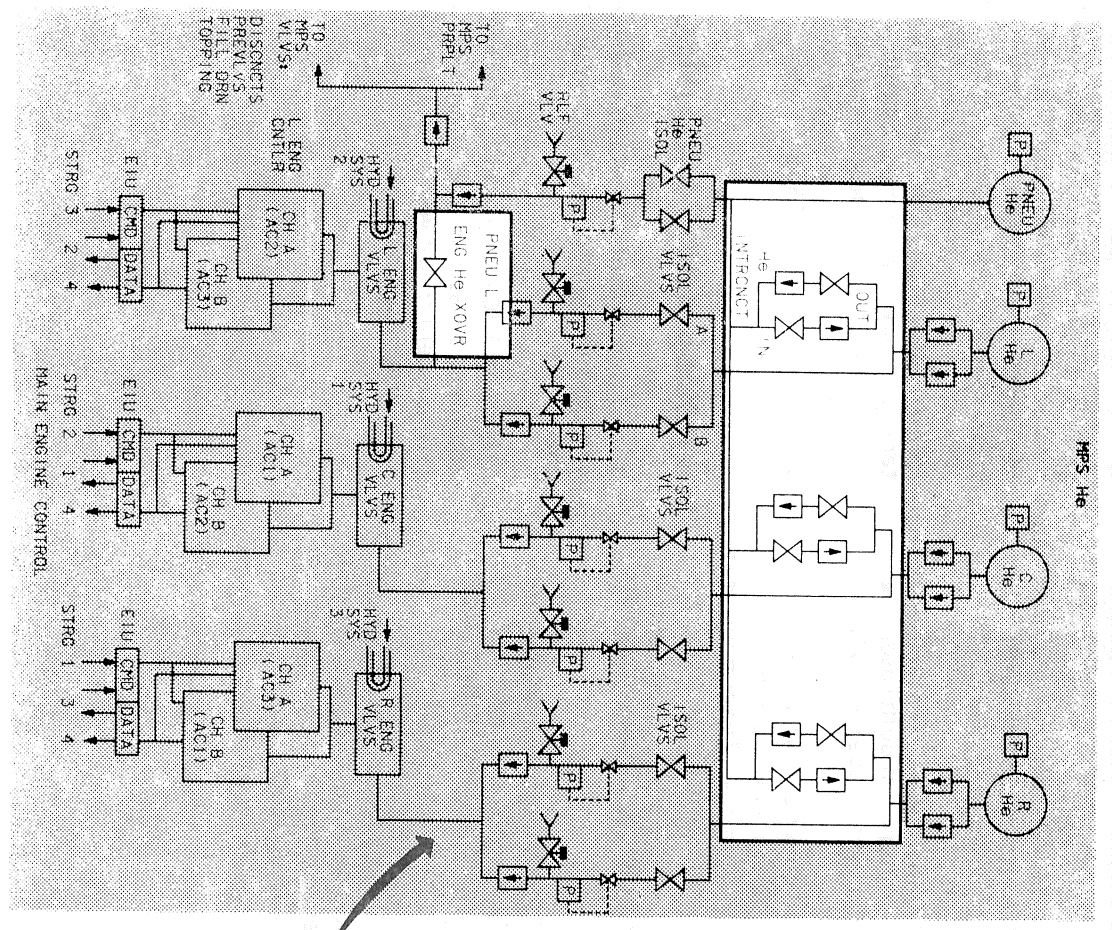

Figure 2-22. Crew controls for the L ENG He XOVR and helium interconnect valves are on panel R2.

External Tank

The ET stores LH2 and LO2 and supplies them under pressure to the three main engines during ascent.

After MECO, the tank is jettisoned, reenters the atmosphere, and impacts in a remote ocean area. Since the tank is not recovered, it contains a minimum number of active components.

The ET is 154 feet long and measures 27.5 feet in diameter. See figure 2-23. It is the largest element of the Space Shuttle and serves as the structural backbone of the vehicle during ascent. The Orbiter is connected to the tank by a single forward attachment and two aft struts. The SRBs are connected by a single forward attachment and by sway braces at the aft segment. The Orbiter and SRBs are separated from the ET by pyrotechnic devices.

The ET has three major components: the forward LO2 tank, an unpressurized intertank which contains most of the electrical components, and the aft LH2 tank. The forward tank holds approximately 143 000 gallons of LO2. The tank nose cone is shaped to reduce drag, contains the ascent air data system, and serves as a lightning rod. The intertank houses the ET instrumentation components and contains the SRB forward attachment points. The aft tank holds approximately 385 000 gallons of LH2 and provides, at its forward end, the forward Orbiter attachment point and, at its aft end, the aft Orbiter and SRB attachment points.

Each propellant tank has a vent and relief valve at its forward end. These dual function valves are controlled by the ground support equipment for the vent function and are open during flight when the LH2 ullage pressure reaches 36 psi or the LO2 ullage pressure reaches 24 psi. The vent function is only available during prelaunch; the relief function is available only in flight. In both cases, the crew has no direct control over this valve.

In addition to its vent and relief valve, the LO2 tank contains a separate pyrotechnically actuated tumble vent valve. The tumble vent valve is opened during the ET SEP sequence. The resultant thrust assists the separation and causes the tank to tumble, providing a more predictable reentry.

There are eight propellant depletion sensors, four for LH2 and four for LO2. The fuel depletion sensors are located at the bottom of the LH2 tank. The oxidizer sensors are mounted in the Orbiter's LO2 feedline manifold. Should any two of the LH2 or LO2 depletion sensors detect a dry condition after the ET low level arm command is received, the GPCs will issue a MECO command, often referred to as a low-level cutoff.

There are also eight ullage pressure sensors, four at the top of each propellant tank (Ullage is the empty space at the top of the tank.) Three of the sensors in the LO2 tank are used to drive the three GO2 flow control valves, one for each engine. Three of the sensors in the LH2 tank drive the three GH2 flow control valves. The fourth sensor in each tank is a spare and can be substituted for a failed sensor before liftoff. The outputs from the three active sensors in each tank are shown on the BFS GNC SYS SUMM 1 display.

Thrust Vector Control

Thrust vector control (TVC) provides attitude control and trajectory shaping by gimballing the SSMEs.

The major TVC subsystems are the MPS TVC command subsystem operating program (SOP), ascent thrust vector control (ATVC), and six hydraulic servoactuators.

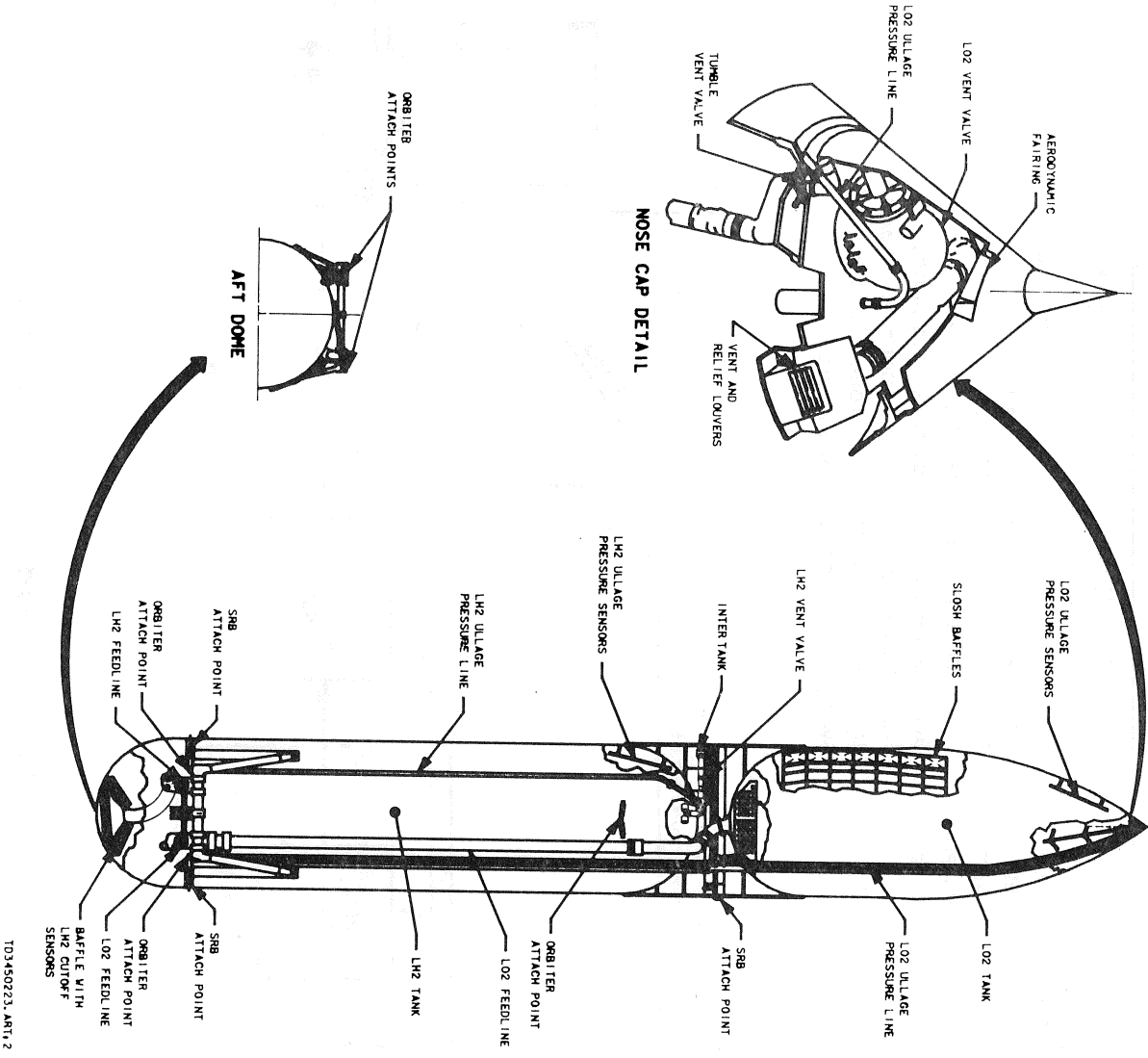
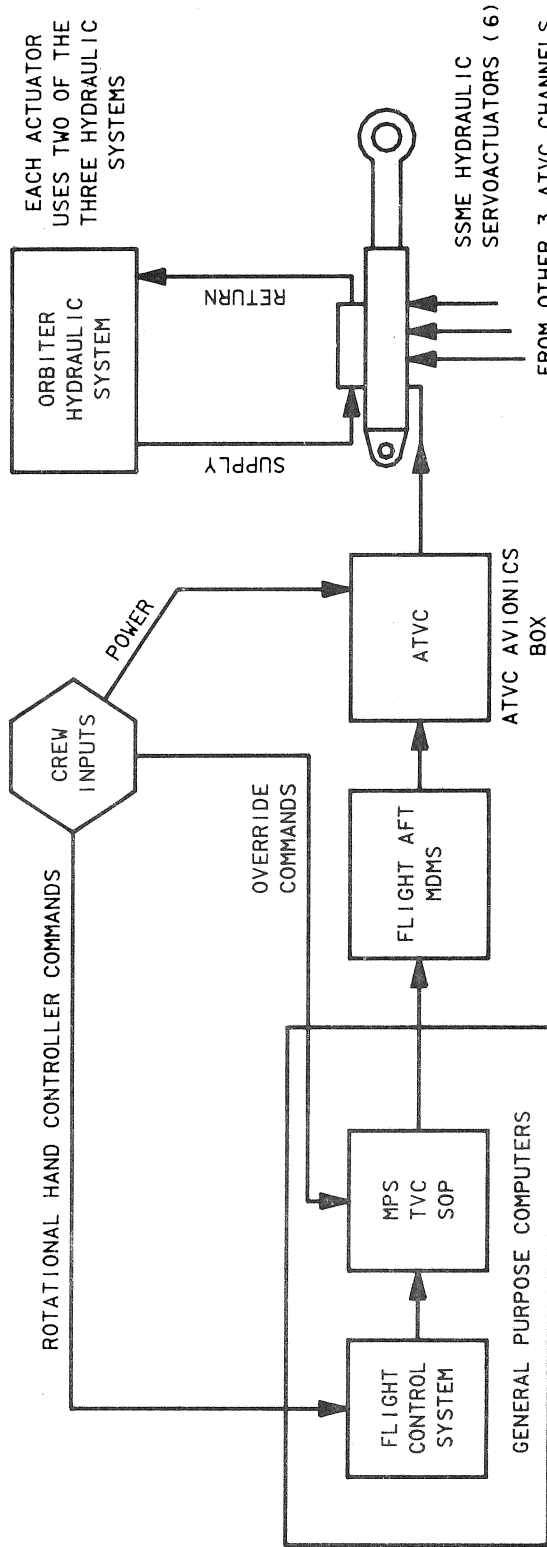

Figure 2-23 - External tank.

Command Flow

Guidance and control requirements are issued to the MPS TVC SOP where they are processed and dispersed to the ATVC avionics boxes. The ATVC is a hardware package which converts digital commands from the GPCs into voltage commands for each hydraulic gimbal actuator.

There are four redundant ATVC channels, each receiving commands from the GPCs and each sending commands to all six servo-actuators. See figure 2-24. Each main engine has two hydraulic servoactuators, one for pitch and one for yaw, that extend or retract to gimbal the engine. See figure 2-25. Each actuator receives four identical commands from the four different ATVC channels. Power to the ATVC channels is controlled by four switches on panel 017. See figure 2-26.



TD3450224, ART 1

Figure 2-24. - MPS TVC interfaces and command flow.

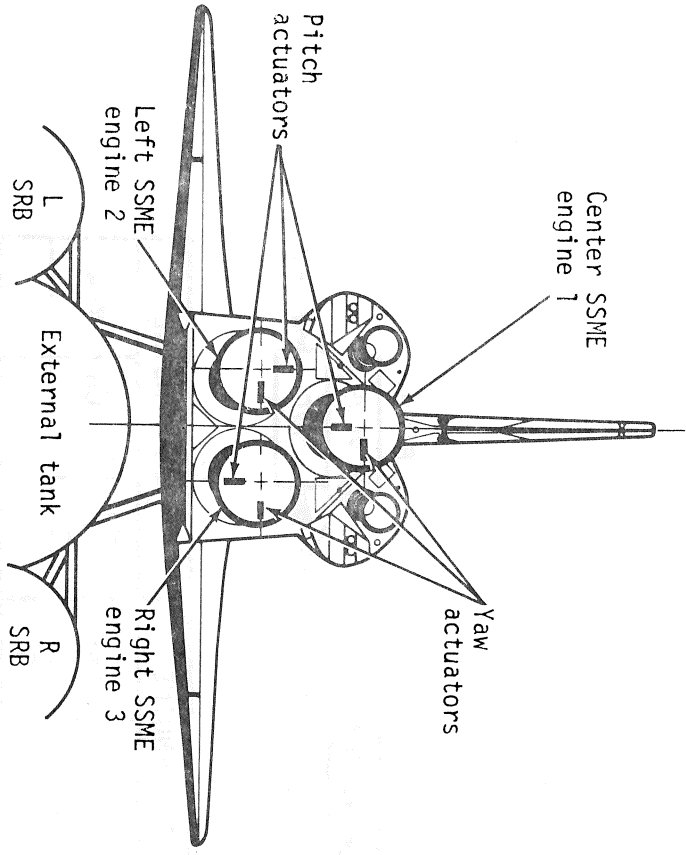

Figure 2-25. - Main engine gimbal actuators.

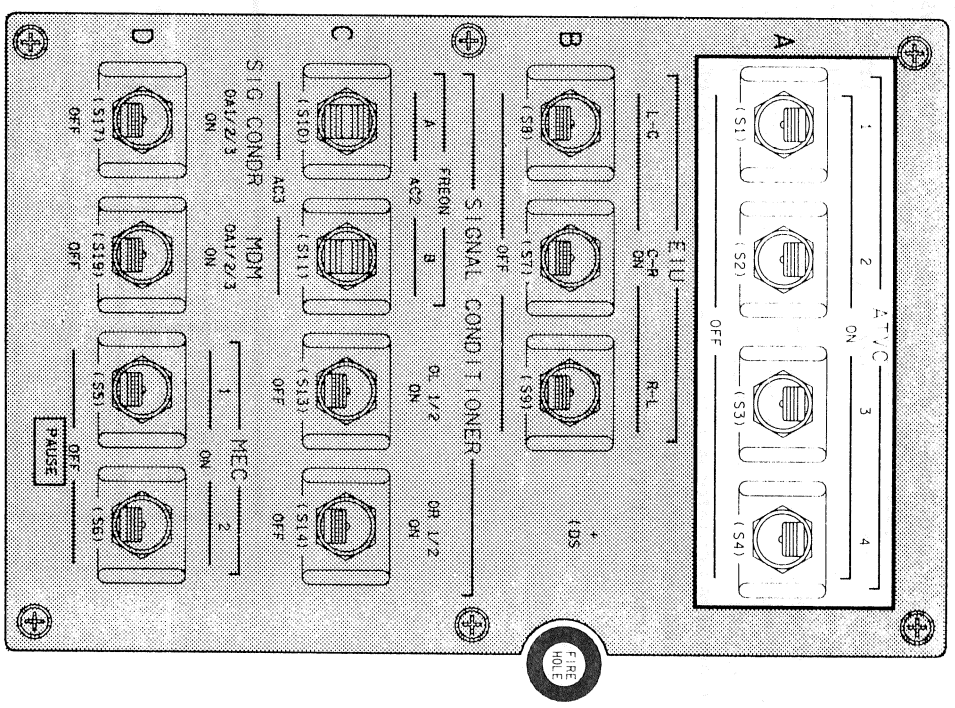

Figure 2-26. - ATVC power is controlled from panel 017.

103450226, ART 1, 2

Hydraulic Interface

Each gimbal actuator uses two of the three Orbiter hydraulic systems for pressure: a primary source and secondary source. Refer to figure 2-27. Normally, the primary system is providing the required hydraulic pressure. If the primary system fails, a switching valve will automatically switch over to the standby system and the actuator will continue to function. For each engine, the primary hydraulic system for the pitch actuator is the

standby system for yaw; conversely, the primary system for the yaw actuator is the standby system for pitch. Note that the primary hydraulic system for the pitch actuator of each engine is the same system used by the valves of that engine. The Orbiter hydraulic systems interface with the MPS TVC actuators and engine valves to equally distribute the workload among the three systems.

For a complete discussion on ATVC, refer to the MPS TVC 2102 training manual.

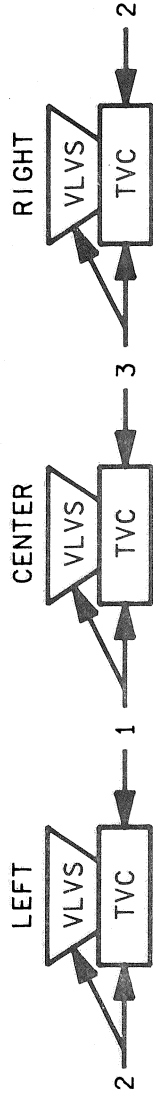

HYDRAULIC SYSTEM	LEFT ENGINE		CENTER ENGINE		RIGHT ENGINE	
	ENG VLV	PITCH YAW	ENG VLV	PITCH YAW	ENG VLV	PITCH YAW
1		S P	P	S		
2	P	P S			S	P
3				S	P	S

P = PRIMARY SYSTEM
S = STANDBY SYSTEM

EACH ACTUATOR HAS TWO HYDRAULIC SYSTEMS (ONE PRIMARY AND ONE BACKUP).

TD3450227. ART. 1

Figure 2-27. - MPS TVC actuator interface with the Orbiter hydraulic systems.

Controls and Displays

The following is a summary of the controls and displays used to operate the MPS. Figure 2-28 shows the locations of the panels containing MPS controls on the forward flight deck.

Switches, meters, or lights on center panel C3; forward panels F2, F4, F6, and F7; overhead panels 014 and 017; left panel L4; and right panels R2 and R4 are illustrated in figures 2-29 through 2-37.

Most of the switches are discussed elsewhere in conjunction with their related systems or crew procedures. Figures 2-38 through 2-42 are examples of the displays used in operating the MPS.

Following each figure is an explanation of the function of the control or display.

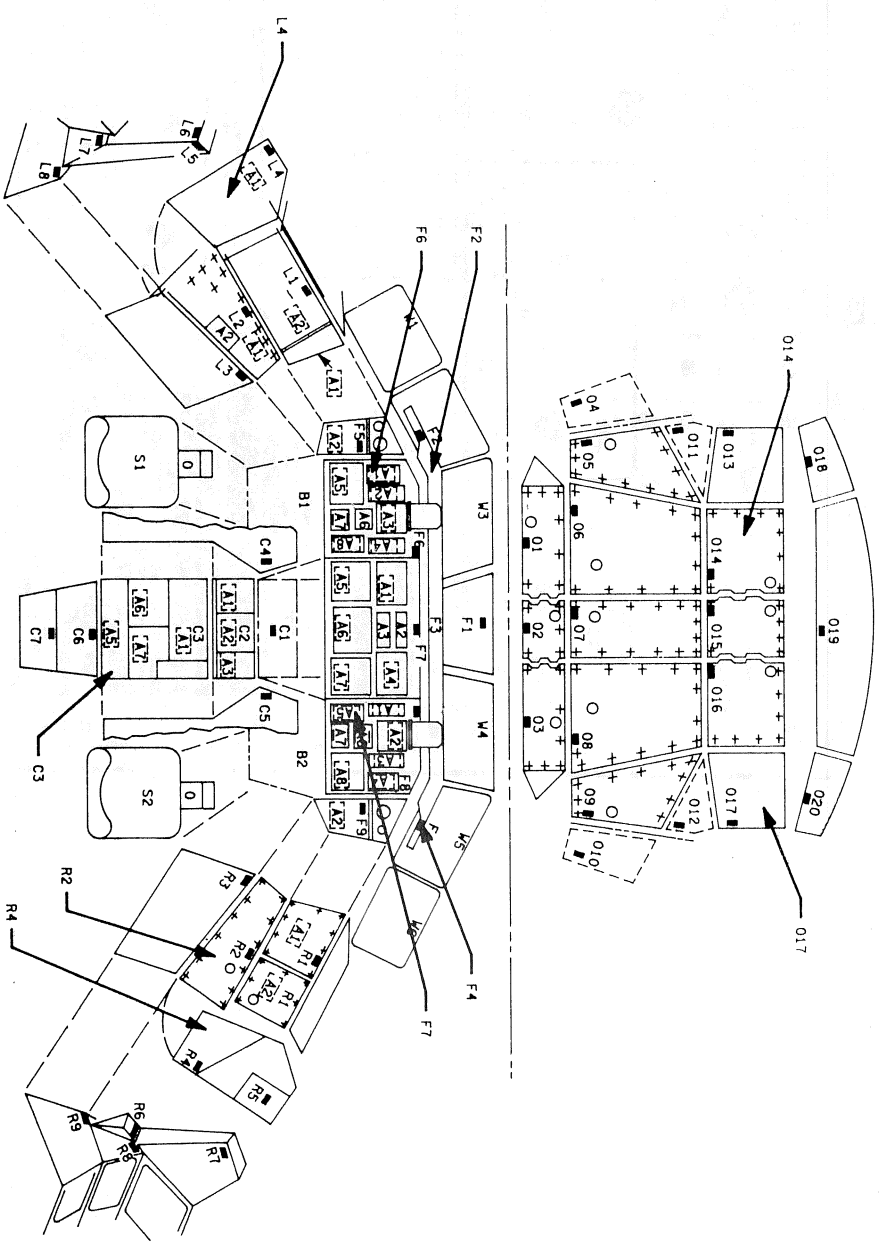
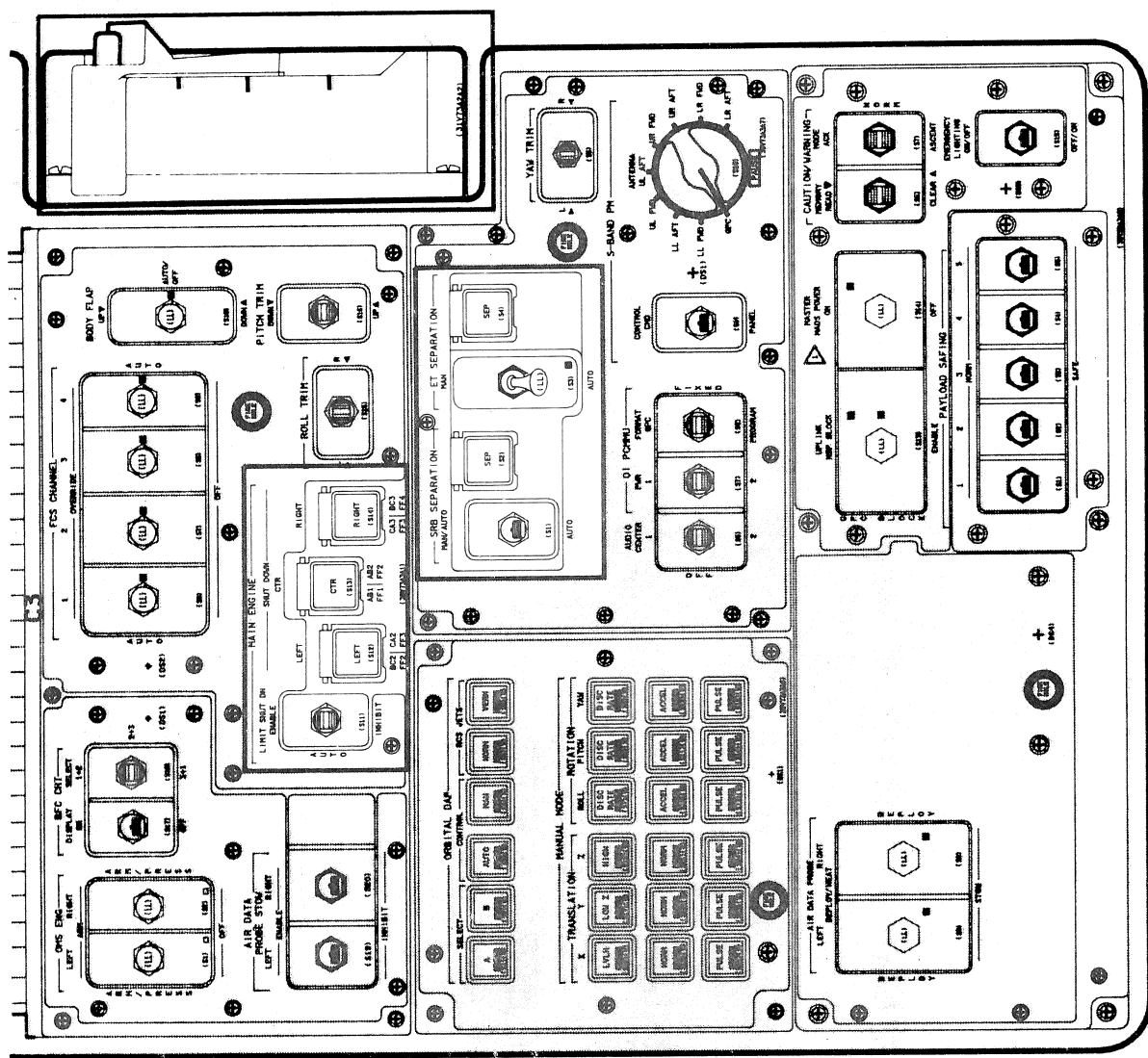

Figure 2-28.— Location of panels containing MPS controls.

TD3450228, ART 1



TD345007R, REV. 1

Figure 2-29. - Panel C3.

CONTROL OR DISPLAY	FUNCTION
MAIN ENGINE LIMIT SHUTDOWN SWITCH ENABLE AUTO INHIBIT	Enables the redline limit shutdown logic for the three main engines. Any engine that exceeds a redline limit will be shut down automatically by its main engine controller. Enables the redline limit shutdown logic for the three main engines. If an engine shuts down early, or any engine experiences a data path failure, the limits are inhibited on the remaining two engines. Inhibits the redline limit shutdown logic for the three main engines.
MAIN ENGINE SHUTDOWN PUSH-BUTTONS (3)	When depressed, a shutdown command is issued to its respective engine. The controller will perform a hydraulic shutdown unless the engine is in hydraulic lockup. In this case, the controller will perform a pneumatic shutdown. If the GPCs do not recognize a shutdown engine due to a data path failure, depressing the applicable pushbutton will tell guidance to account for the failed engine and close the prevalves of that engine. Depressing all three buttons simultaneously will manually set the MECO CONFIRMED flag. This feature is used after MECO when two or more data path failures occur prior to MECO.
SRB SEPARATION SWITCH MAN/AUTO AUTO	Provides power to the SRB SEPARATION pushbutton. During ascent, this allows the crew to override any software separation inhibits (body rates or dynamic pressure) by depressing the pushbutton. An AUTO separation will still occur with the switch in this position if all separation constraints are met. During entry, it allows the crew to set the weight on wheels (WOW) and weight on nose gear (WONG) disretes. Removes power from the SRB SEPARATION pushbutton placing the separation software in an AUTO-only mode.
SRB SEPARATION PUSHBUTTON	Enabled, if the SRB SEPARATION switch is in MAN/AUTO. When depressed, it allows the crew to override any software separation inhibits so the separation sequence can continue. The manual separation input cannot be processed until 125 seconds after SRB ignition. This is after $P_c < 50$, thrust decay, and actuator null. During entry, the pushbutton sets the WOW and WONG disretes.

Figure 2-29. – Continued.

CONTROL OR DISPLAY	FUNCTION
ET SEPARATION SWITCH MAN AUTO	Provides power to the ET SEPARATION pushbutton. During ascent, this allows the crew to inhibit an AUTO separation and perform a manual separation by depressing the pushbutton. During entry, it allows the crew to set the WOW and WONG discretes. Removes power from the ET SEPARATION pushbutton placing the separation software in an AUTO-only mode.
ET SEPARATION PUSHBUTTON	Enabled, if the ET SEPARATION switch is in MAN. When depressed, it initiates a manual separation allowing the crew to override any software inhibits. During entry, the pushbutton sets the WOW and WONG discretes.
SPEEDBRAKE/THRUST CONTROLLER TAKEOVER PUSHBUTTON LEVER	When depressed, signals the GPCs of the intent to engage manual throttle. Manual control of the thrust function is established by depressing the takeover pushbutton, matching the throttle position to within 4 percent of the current AUTO command, and then releasing the pushbutton. When MANUAL mode is established, lever is used to throttle the main engines in MM 102, 103, and 601. (NOTE: This lever is also used for manual speedbrake control during gliding flight.) There is no manual throttle capability with BFS engaged. Also, only the pilot can throttle manually. The commander's lever can be used as a speedbrake control only.

Figure 2-29. – Concluded.

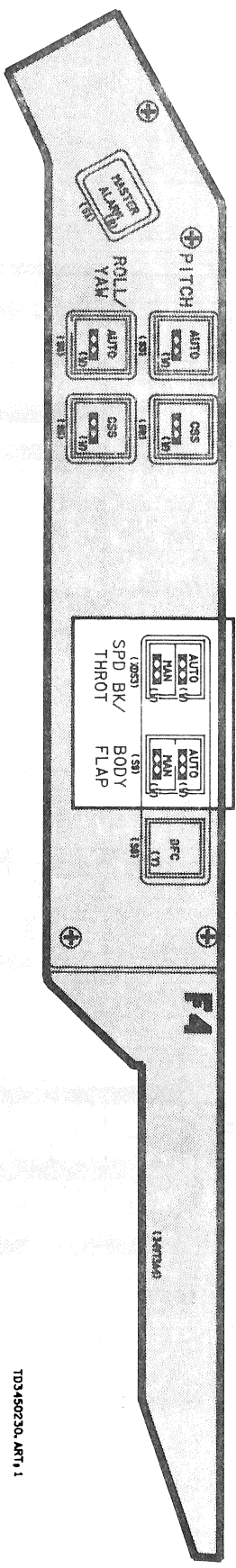
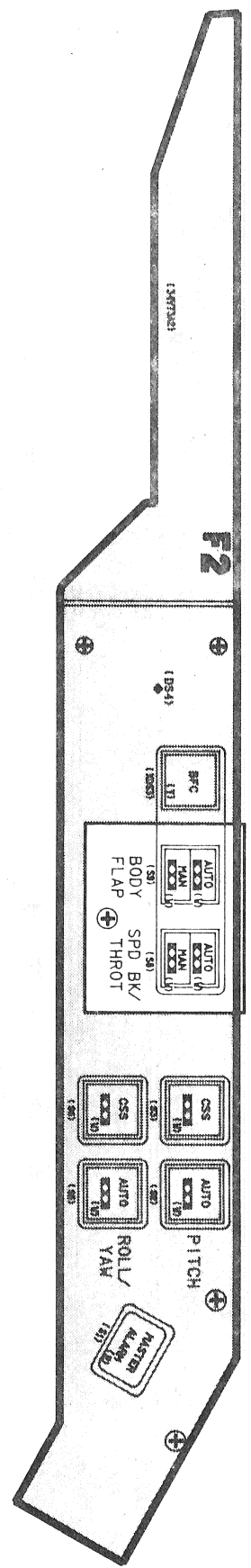

1D3450230, ART 1

CONTROL OR DISPLAY	FUNCTION
SPD BK/THROT PUSHBUTTON INDICATOR (pbi)	Changes the throttle function from MANUAL to AUTO. (Also used to control the speedbrake during gliding flight.)
DEPRESS AUTO LIGHT (white) MAN LIGHT (white)	Indicates the throttle (or speedbrake) is in the AUTO mode. Indicates the throttle (or speedbrake) is in the MANUAL mode.
BODY FLAP pbi	Primary use is for control/status of the body flap. Relating to the MPS, the body flap light is illuminated at the transition to MM 101 and is extinguished when the MPS dump is complete.

Figure 2-30. - Panels F2 and F4.

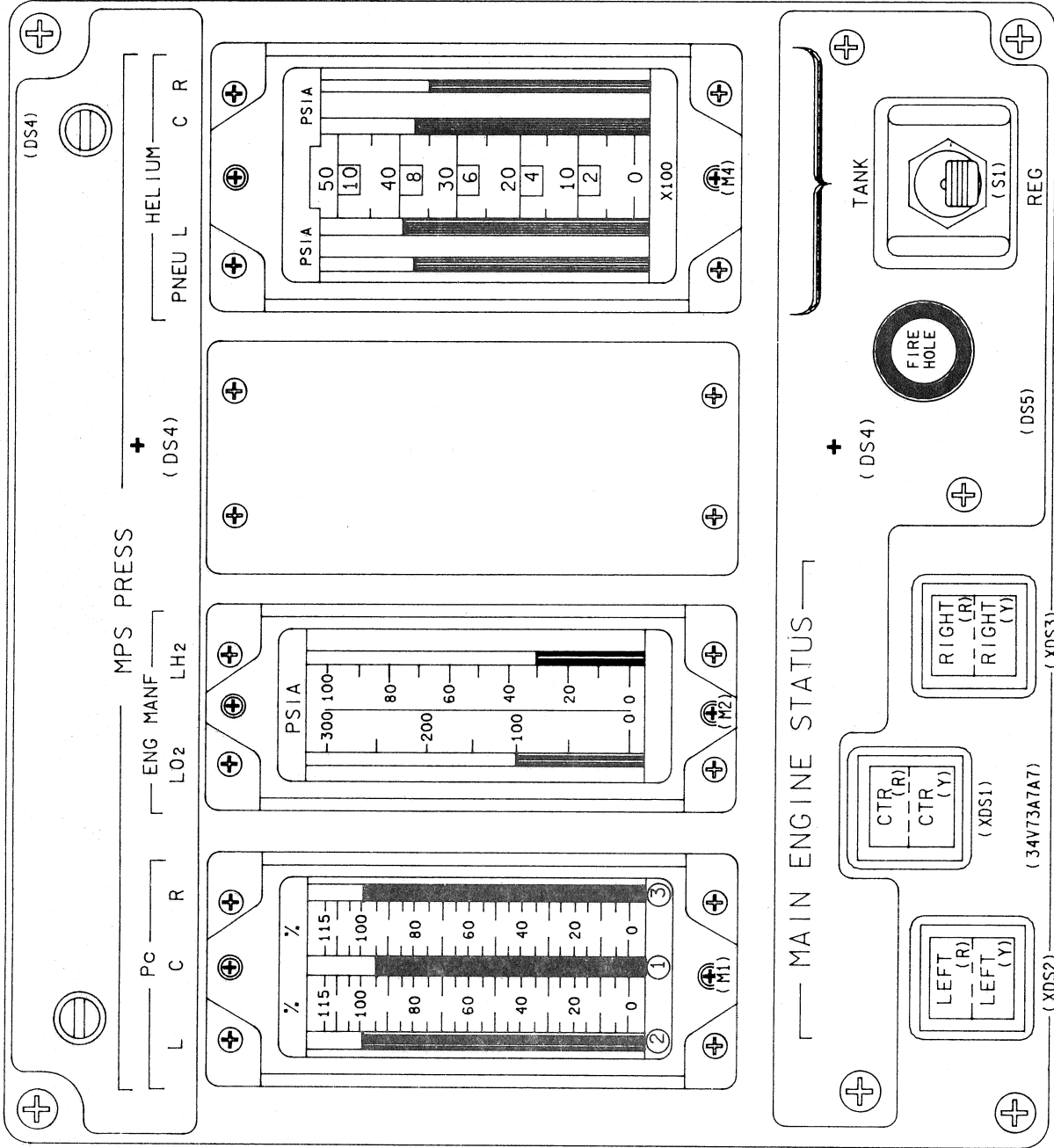

TD3450231. ART. 2

Figure 2-31. - MPS displays on Panel F7.

CONTROL OR DISPLAY	FUNCTION
MPS PRESS Pc METERS (3)	Display left, center, and right main engine combustion chamber pressure in percent (0% to 115%).
MPS PRESS ENG MANF METERS	
LO2	Displays LO2 manifold pressure in the line between the ET and the main engines (0 to 300 psia).
LH2	Displays LH2 manifold pressure in the line between the ET and the main engines (0 to 100 psia).
MPS PRESS HELIUM METERS (4)	Displays pneumatic, left, center, and right MPS helium supply tank pressures when TANK is selected with the MPS PRESS HELIUM switch (0 to 5000 psia). Displays pneumatic regulator pressure and left, center, and right A regulator pressures when REG is selected with the MPS PRESS HELIUM switch (0 to 1000 psia). Tank pressure is read with the numbers above the lines (X100) on the meter. Regulator pressure is read using the numbers in the boxes below the lines (X100).
MPS PRESS HELIUM SWITCH	
TANK	Displays helium tank pressures on the MPS PRESS HELIUM meters.
REG	Displays regulator pressures on the MPS PRESS HELIUM meters.
MAIN ENGINE STATUS LIGHTS (3)	
RED	The top half of the light illuminates red if its associated engine shuts down or if a redline limit is exceeded when the limit shutdown software is inhibited. All three lights illuminate at MECO and extinguish at ET separation.
YELLOW	The bottom half of the light illuminates yellow for a data path failure, command path failure, hydraulic lockup, or electrical lockup.

Figure 2-31. -- Concluded.

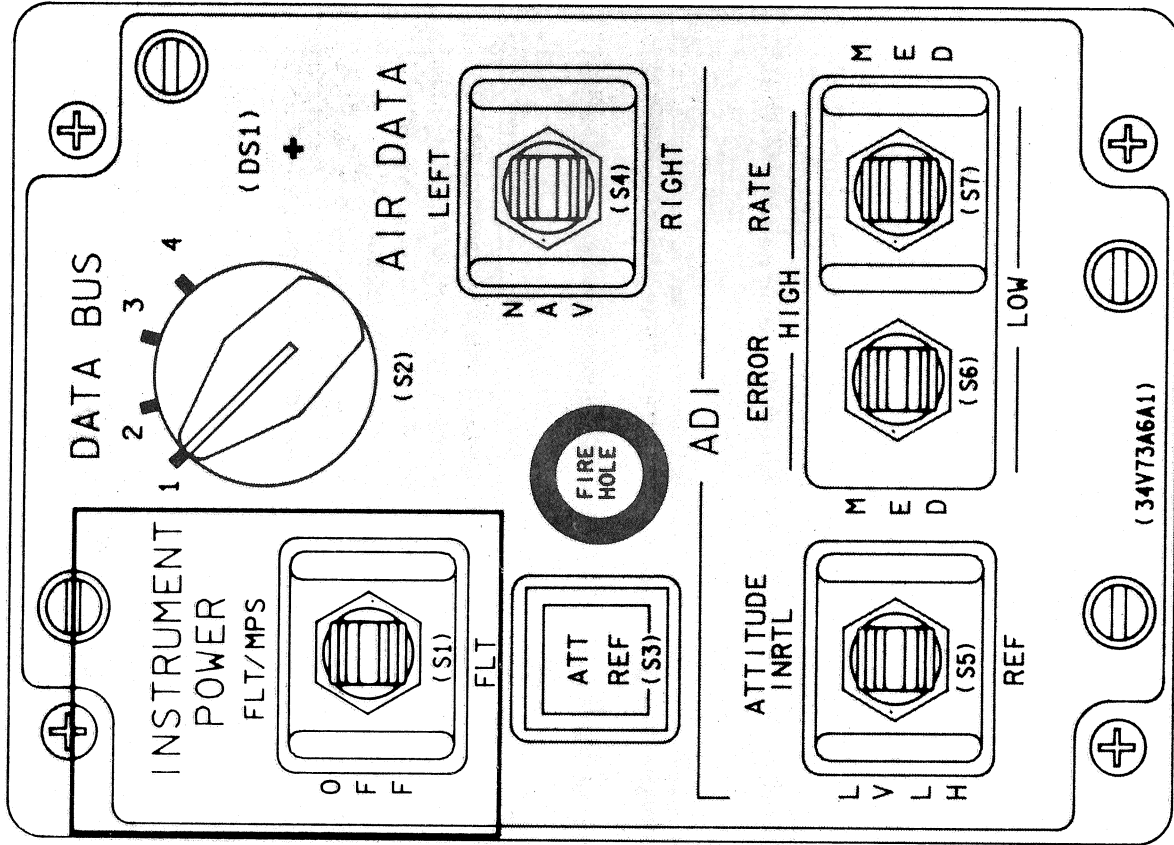

TD3450232. ART. 1

Figure 2-32. - INSTRUMENT POWER switch on panel F6.

CONTROL OR DISPLAY	FUNCTION
INSTRUMENT POWER SWITCH	
FLT/MPS	Applies power to the flight-critical dedicated displays, on panels F6 and F7, and the MPS PRESS meters on panel F7.
OFF	Removes power from the displays and meters listed in the other two positions.
FLT	Applies power to the flight-critical dedicated displays on panels F6 and F7.

Figure 2-32. -- Concluded.

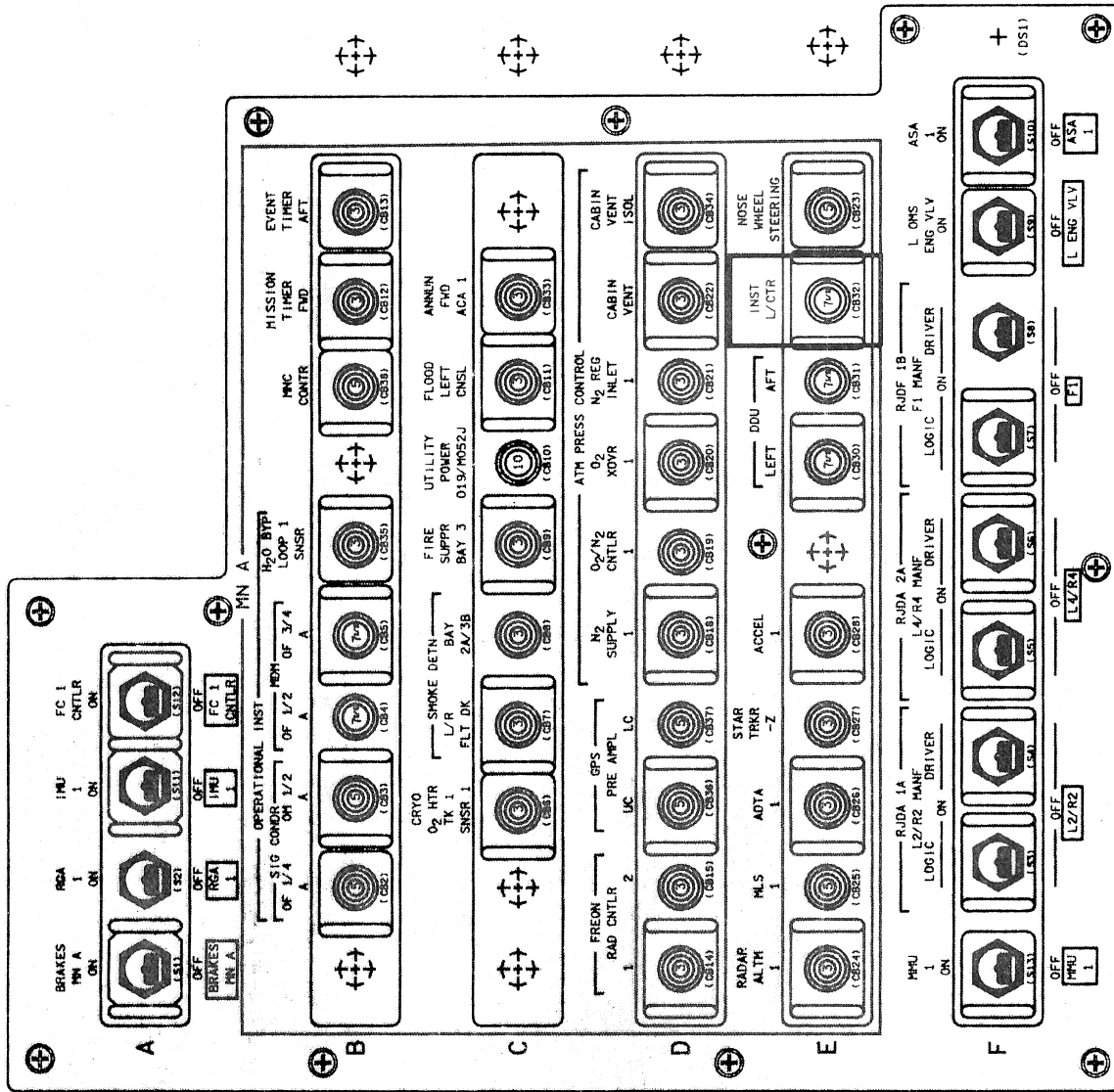

TD3450233-ART1

Figure 2-33.- Panel 014.

CONTROL OR DISPLAY	FUNCTION
INST UCTR CIRCUIT BREAKER (cb)	Provides power to the left and center flight-critical dedicated displays (panels F6 and F7) and MPS PRESS meters (panel F7).

Figure 2-33. -- Concluded.

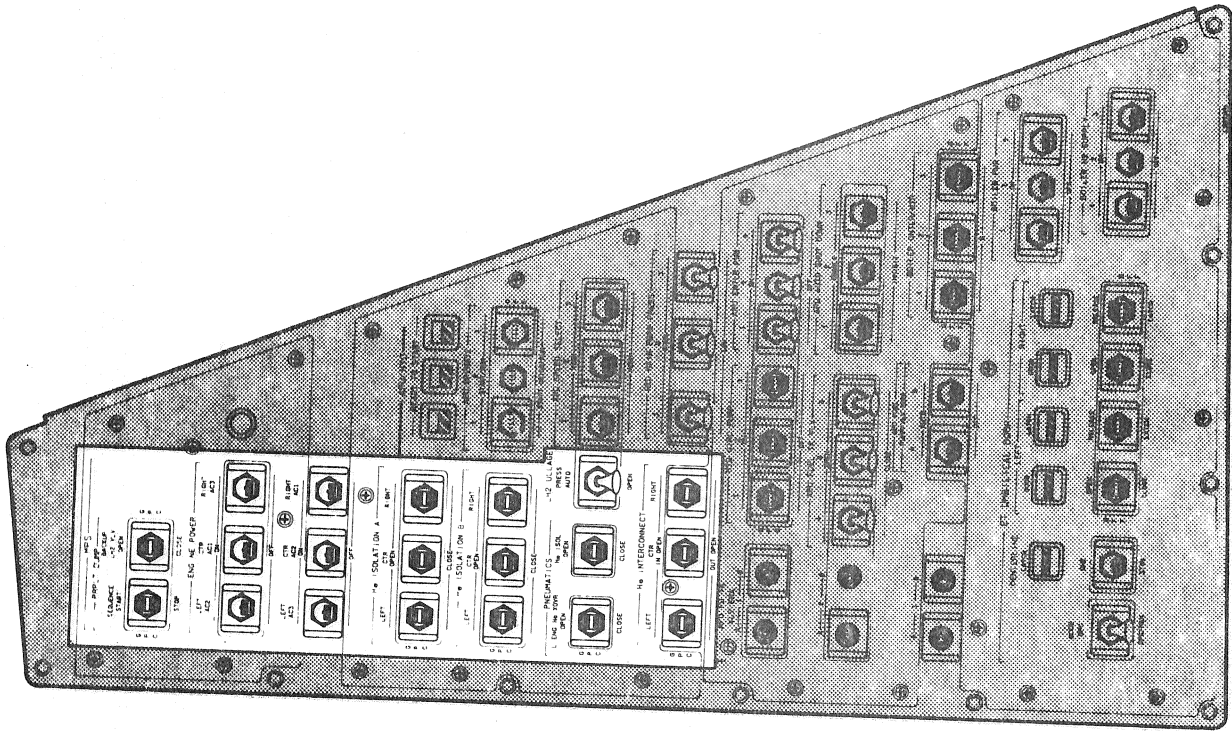

TD345023A, ART. 1

Figure 2-34. - Panel R2.

CONTROL OR DISPLAY	FUNCTION
MPS PRPLT DUMP SEQUENCE SWITCH START GPC STOP	Manually starts the MPS propellant dump sequence post-MECO. The remainder of the sequence, including dump termination, is automatic. Allows the GPCs to start the MPS propellant dump at OMS-1 ignition. Inhibits the GPCs from starting the dump if it has not occurred yet.
MPS PRPLT DUMP BACKUP LH2 VLV SWITCH OPEN GPC CLOSE	Opens the backup LH2 dump valves - also known as RTLS dump valves. Allows the GPCs to control the backup LH2 dump valves. Closes the backup LH2 dump valves.
MPS ENGINE POWER SWITCHES (6) LEFT AC2 ON OFF LEFT AC3 CENTER AC1 CENTER AC2 RIGHT AC3 RIGHT AC1	Applies ac power to the left engine controller DCU A. Removes ac power from the left engine controller DCU A. Same as LEFT AC2 except it provides power to the left controller DCU B. Same as LEFT AC2 except it provides power to the center controller DCU A. Same as LEFT AC2 except it provides power to the center controller DCU B. Same as LEFT AC2 except it provides power to the right controller DCU A. Same as LEFT AC2 except it provides power to the right controller DCU B.

Figure 2-34. - Continued.

CONTROL OR DISPLAY	FUNCTION
MPS HELIUM ISOLATION SWITCHES (6)	
LEFT A	Opens the A leg isolation valve for the left engine helium system.
OPEN	Allows the GPCs to control the A leg isolation valve.
GPC	Closes the A leg isolation valve for the left engine helium system.
CLOSE	Same as LEFT A except for the LEFT B isolation valve.
LEFT B	Same as LEFT A except for the CENTER A isolation valve.
CENTER A	Same as LEFT A except for the CENTER B isolation valve.
CENTER B	Same as LEFT A except for the RIGHT A isolation valve.
RIGHT A	Same as LEFT A except for the RIGHT B isolation valve.
RIGHT B	
MPS PNEUMATIC L ENG HELIUM XOVR SWITCH	
OPEN	Opens the L ENG He XOVR valve allowing helium from the left helium tank to supply the pneumatic system.
GPC	Allows the GPCs to control the L ENG He XOVR valve.
CLOSE	Closes the L ENG He XOVR valve.

Figure 2-34. – Continued.

CONTROL OR DISPLAY	FUNCTION
MPS PNEUMATIC HELIUM ISOLATION SWITCH OPEN GPC CLOSE	Opens the two pneumatic helium isolation valves. Allows the GPCs to control the valves. Closes the two pneumatic helium isolation valves.
MPS He INTERCONNECT LEFT SWITCH IN OPEN GPC OUT OPEN MPS He INTERCONNECT CENTER SWITCH MPS He INTERCONNECT RIGHT SWITCH	Opens the inlet interconnect valve allowing helium from the pneumatic tank and interconnect manifold to supply the left engine system. Inhibits power to the outlet interconnect valve to ensure it remains closed. Allows the GPCs to control the interconnect valves. Opens the outlet interconnect valve allowing helium from the left engine system to supply the interconnect manifold and pneumatic system. Inhibits power to the inlet interconnect valve to ensure it remains closed. Same as the INTERCONNECT LEFT except for the center helium system. Same as the INTERCONNECT LEFT except for the right helium system.
MPS LH2 ULLAGE PRESS SWITCH AUTO OPEN	Enables automatic control of the three GH2 flow control valves which open and close to maintain proper ullage pressure in the LH2 tank. Opens the three GH2 flow control valves allowing maximum flow from the engines to the LH2 tank, thus increasing ullage pressure.

Figure 2-34. – Concluded.

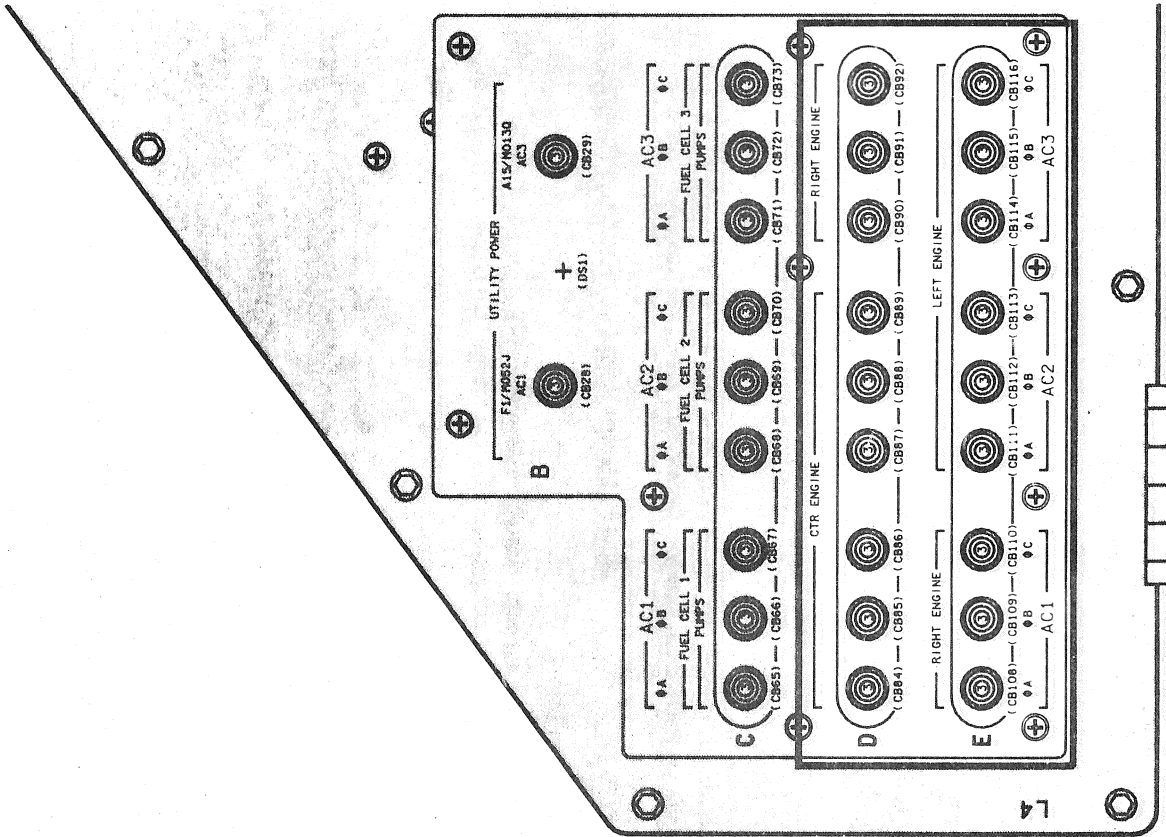

TD3450235, ART. 1

Figure 2-35.-- Panel L4.

CONTROL OR DISPLAY	FUNCTION
CENTER ENGINE AC1 ØA, ØB, ØC cb (3)	Supplies ac power to the center engine controller DCU A.
CENTER ENGINE AC2 ØA, ØB, ØC cb (3)	Supplies ac power to the center engine controller DCU B.
RIGHT ENGINE AC3 ØA, ØB, ØC cb (3)	Supplies ac power to the right engine controller DCU A.
RIGHT ENGINE AC1 ØA, ØB, ØC cb (3)	Supplies ac power to the right engine controller DCU B.
LEFT ENGINE AC2 ØA, ØB, ØC cb (3)	Supplies ac power to the left engine controller DCU A.
LEFT ENGINE AC3 ØA, ØB, ØC cb (3)	Supplies ac power to the left engine controller DCU B.

Figure 2-35. – Concluded.

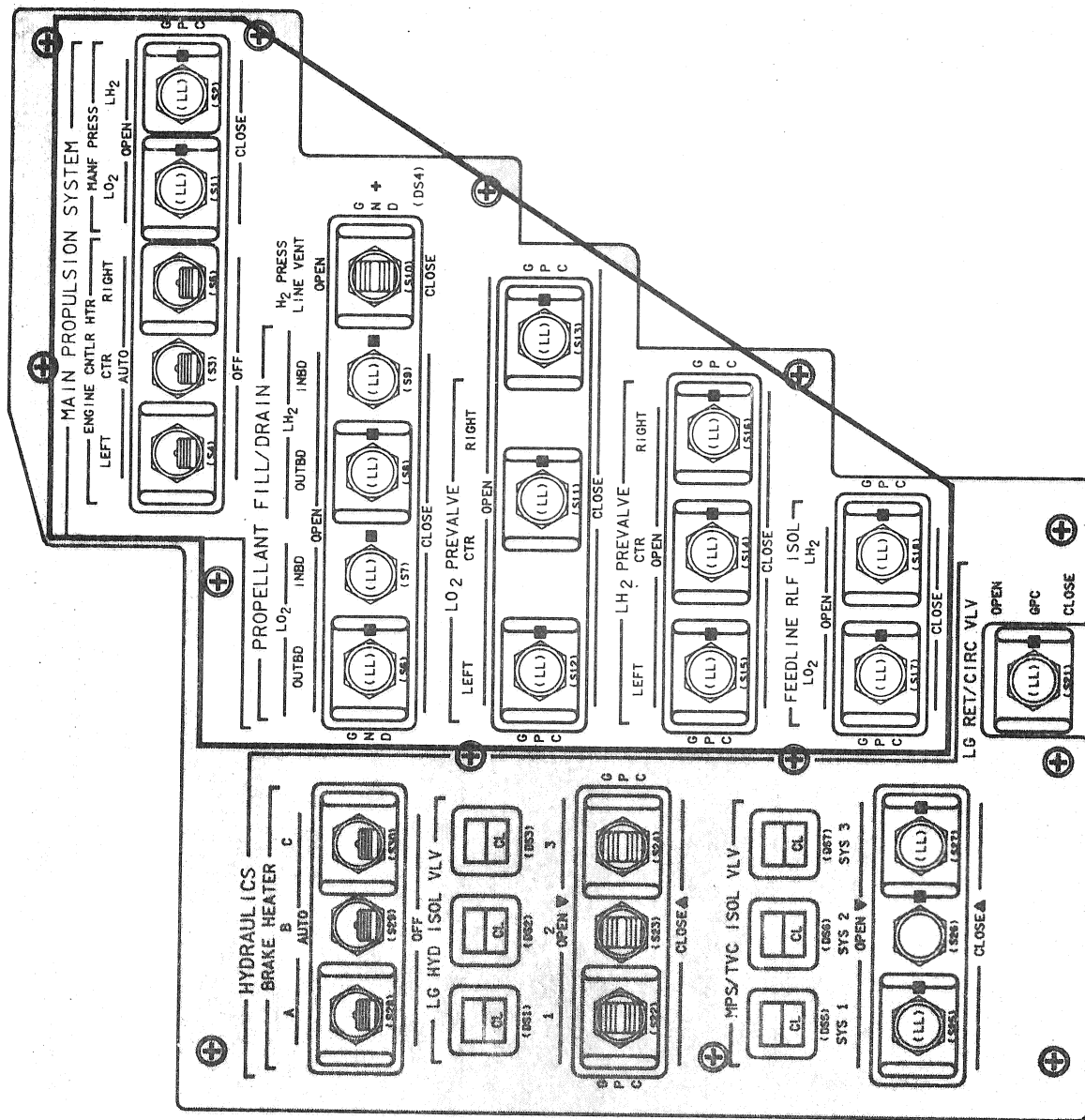

Figure 2-36. - Panel R4.

TD3450236, ART. 1

CONTROL OR DISPLAY	FUNCTION
MPS ENGINE CONTROLLER HEATER SWITCHES (3) LEFT AUTO OFF CENTER RIGHT	Applies power to a thermostatically-controlled heater allowing automatic temperature control of the left engine controller. Removes power from the heater. Same as LEFT except for the center engine controller. Same as LEFT except for the right engine controller.
MPS MANIFOLD PRESSURE LO2 SWITCH OPEN GPC CLOSE MPS MANIFOLD PRESSURE LH2 SWITCH	Opens the LO2 manifold pressure valves allowing helium to flow into the LO2 feedline manifold. Allows the GPCs to control the LO2 manifold pressure valves. Closes the LO2 manifold pressure valves isolating the LO2 feedline manifold from the helium supply. Same as the MPS MANIFOLD PRESSURE LO2 switch except for the LH2 feedline manifold.

Figure 2-36. – Continued.

CONTROL OR DISPLAY	FUNCTION
MPS PROPELLANT FILL/DRAIN LO2 OUTBOARD SWITCH	
OPEN	Opens the LO2 outboard fill/drain valve.
GND	Allows the GPCs or launch processing system to control the valve.
CLOSE	Closes the LO2 outboard fill/drain valve.
MPS PROPELLANT FILL/DRAIN LO2 INBOARD SWITCH	Same as MPS PROPELLANT FILL/DRAIN LO2 OUTBOARD switch except for the LO2 inboard fill/drain valve.
MPS PROPELLANT FILL/DRAIN LH2 OUTBOARD SWITCH	Same as MPS PROPELLANT FILL/DRAIN LO2 OUTBOARD switch except for the LH2 outboard fill/drain valve.
MPS PROPELLANT FILL/DRAIN LH2 INBOARD SWITCH	
OPEN	Opens the LH2 inboard fill/drain valve and the LH2 topping valve.
GND	Allows the GPCs or launch processing system to control the valves.
CLOSE	Closes the LH2 inboard fill/drain valve and the LH2 topping valve.
MPS H2 PRESS LINE VENT SWITCH	
OPEN	Opens the MPS H2 PRESS LINE VENT valve allowing GH2 in the line to vent overboard.
GND	Allows the GPCs, through the launch processing system, to open the valve. If an OPEN command is not present, the valve closes.
CLOSE	Closes the MPS H2 PRESS LINE VENT valve.

Figure 2-36. – Continued.

CONTROL OR DISPLAY	FUNCTION
<p>MPS PREVALVE SWITCHES (6)</p> <p>LO2 LEFT</p> <p>OPEN</p> <p>GPC</p> <p>CLOSE</p> <p>LO2 CENTER</p> <p>LO2 RIGHT</p> <p>LH2 LEFT</p> <p>LH2 CENTER</p> <p>LH2 RIGHT</p>	<p>Opens the LO2 prevalve to the left main engine.</p> <p>Allows the GPCs to control the valve.</p> <p>Closes the LO2 prevalve to the left main engine.</p> <p>Same as LO2 LEFT except for the center engine.</p> <p>Same as LO2 LEFT except for the right engine.</p> <p>Same as LO2 LEFT except LH2 prevalve for the left engine.</p> <p>Same as LO2 LEFT except LH2 prevalve for the center engine.</p> <p>Same as LO2 LEFT except LH2 prevalve for the right engine.</p>
<p>MPS FEEDLINE RELIEF ISOLATION LO2 SWITCH</p> <p>OPEN</p> <p>GPC</p> <p>CLOSE</p> <p>MPS FEEDLINE RELIEF ISOLATION LH2 SWITCH</p>	<p>Opens the LO2 feedline relief isolation valve allowing pressure in the LO2 manifold to vent overboard.</p> <p>Allows the GPCs to control the valve.</p> <p>Closes the LO2 feedline relief isolation valve.</p> <p>Same as MPS FEEDLINE RELIEF ISOLATION LO2 switch except for the LH2 manifold.</p>

Figure 2-36. -- Concluded.

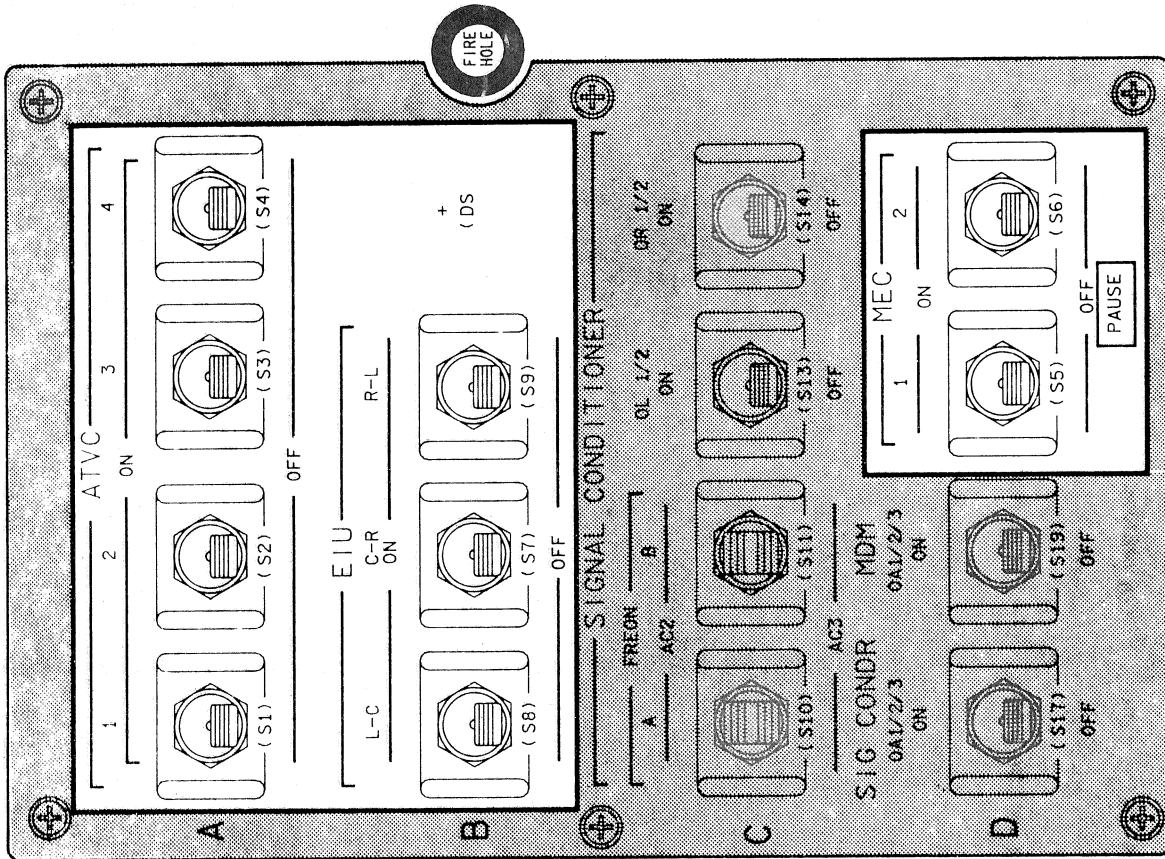

TD3450237. ART. 3

Figure 2-37. - Panel 017.

CONTROL OR DISPLAY	FUNCTION
<p>ATVC 1 SWITCH</p> <p>ON</p>	<p>Applies power to the ATVC 1 electronics that process the position commands to the channel 1 main engine and SRB hydraulic actuator servovalves. Also applies power to the hydraulic actuator isolation valve drivers.</p>
<p>OFF</p> <p>ATVC 2 SWITCH</p> <p>ATVC 3 SWITCH</p> <p>ATVC 4 SWITCH</p>	<p>Removes power from the ATVC 1 electronics.</p> <p>Same as ATVC 1 switch except ATVC 2 and channel 2.</p> <p>Same as ATVC 1 switch except ATVC 3 and channel 3.</p> <p>Same as ATVC 1 switch except ATVC 4 and channel 4.</p>
<p>EIU L-C SWITCH</p> <p>ON</p> <p>OFF</p> <p>EIU C-R SWITCH</p> <p>EIU R-L SWITCH</p>	<p>Applies power to the left and center EIUs enabling command and data transfer between the GPCs and left and center engine controllers.</p> <p>Removes power from the left and center EIUs.</p> <p>Same as EIU L-C switch except for the center and right EIUs and engine controllers.</p> <p>Same as EIU L-C switch except for the right and left EIUs and engine controllers.</p> <p>NOTE: Switches are redundant to each other. Only one needs to be on to supply power to its two associated EIUs, and two switches must be off to remove power from any EIU.</p>
<p>MEC1 SWITCH</p> <p>ON</p> <p>OFF</p> <p>MEC 2 SWITCH</p>	<p>Applies power to MEC 1 enabling the MEC launch, staging, and ET separation functions.</p> <p>Removes power from MEC 1.</p> <p>Same as MEC 1 except MEC 2.</p>

Figure 2-37. – Concluded.

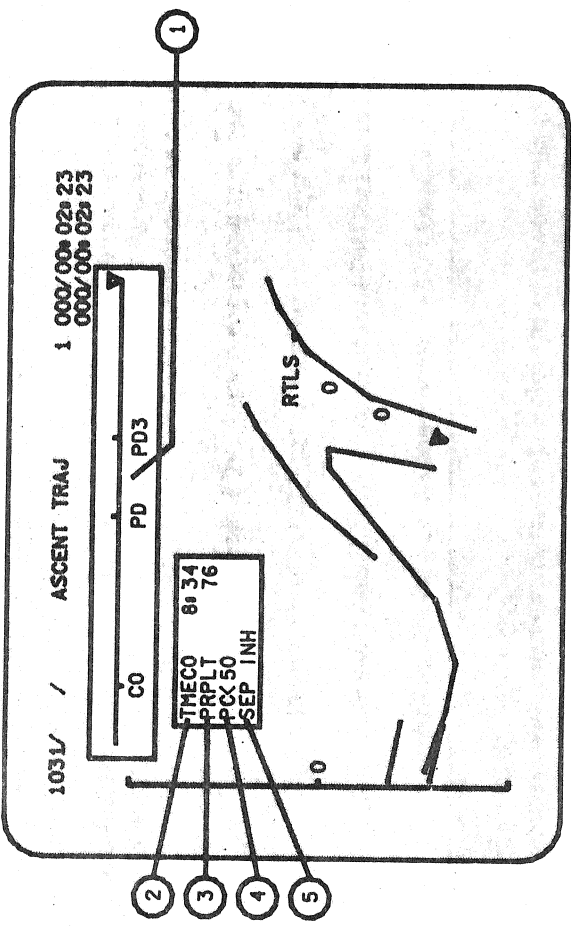

TD3450236. ART 1

CONTROL OR DISPLAY	FUNCTION
① DELTA RANGE SCALE	The scale across the top is delta range (ΔR). ΔR is the glide range potential based on energy state minus present range from the landing site. Current ΔR is indicated by a moving triangle. Tick marks are placed where powered pitchdown normally occurs at MECO minus 20 seconds (PD), where powered pitchdown occurs for a three-engine RTLS case (PD3), and where MECO occurs (CO). The ΔR scale is active only during an RTLS abort.
② TMECO	TMECO is the predicted time of MECO, in minutes and seconds from lift-off.
③ PRPLT	PRPLT indicates the percent of propellant remaining in the ET.
④ PC < 50	PC < 50 is displayed when the SRB chamber pressures drop below 50 psi prior to separation.
⑤ SEP INH	SEP INH is displayed in MM102 if SRB AUTO separation is inhibited and is blanked upon transition to MM103. SEP INH is also displayed in MM103 if ET AUTO separation is inhibited.

Figure 2-38. - PASS ASCENT TRAJ display.

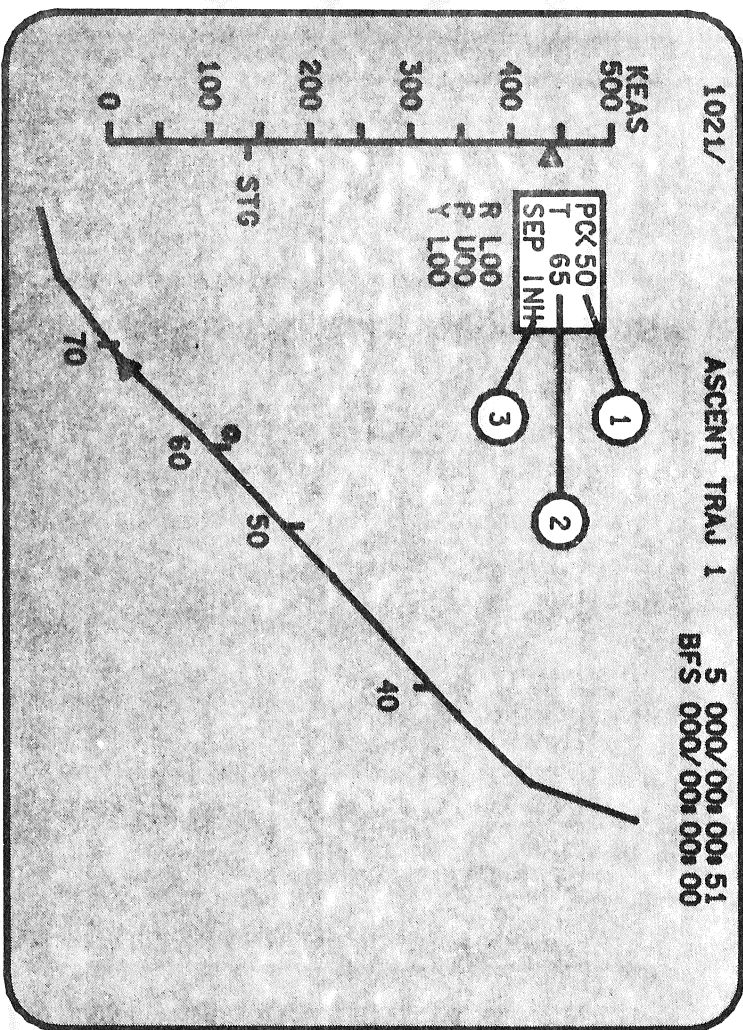

TD3450239, ART, 1

CONTROL OR DISPLAY	FUNCTION
① Pc < 50	Pc < 50 is displayed when the SRB chamber pressures drop below 50 psi prior to separation.
② T	T indicates the throttle command, in percent, generated by the BFS.
③ SEP INH	SEP INH is displayed if SRB AUTO separation is inhibited.

Figure 2-39. - BFS ASCENT TRAJECTORY 1 display.

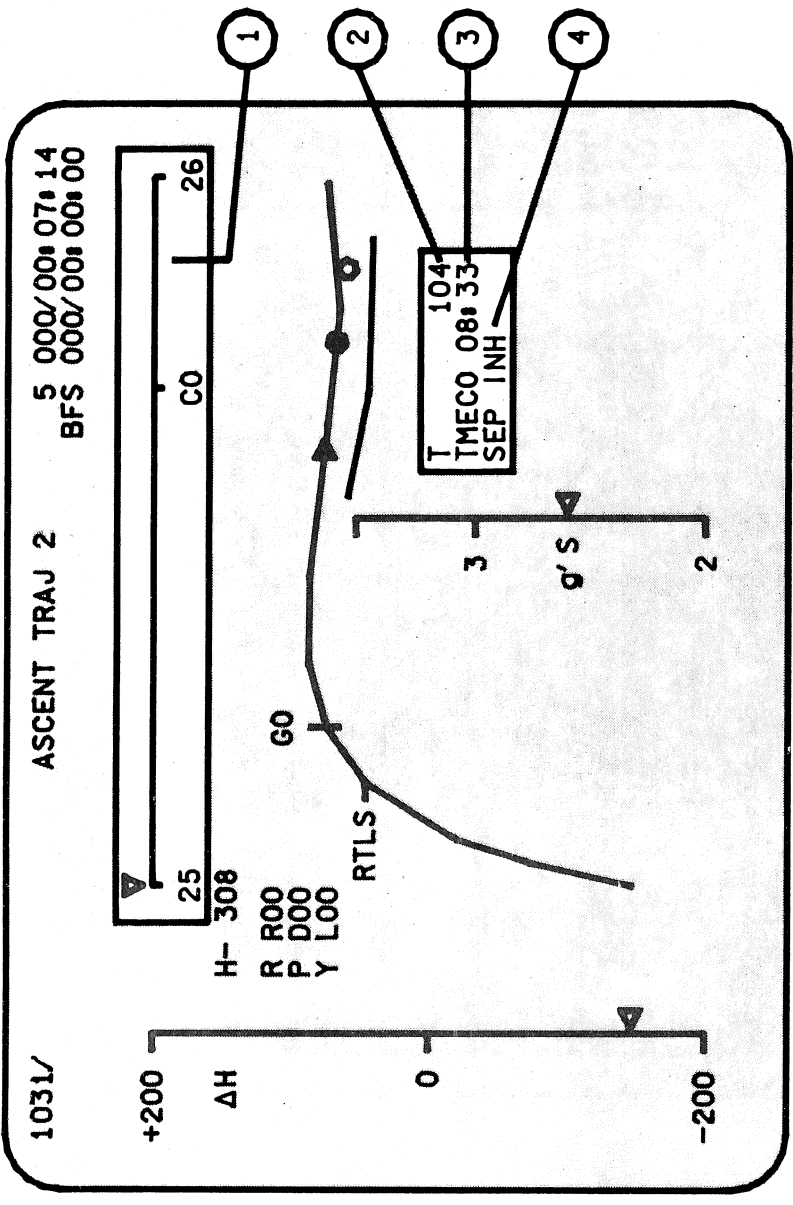

TD3450240. ART, 2

Figure 2-40. - BFS ASCENT TRAJ 2 display.

CONTROL OR DISPLAY	FUNCTION
① INERTIAL VELOCITY SCALE	The scale across the top is an inertial velocity scale within mission-dependent, I-loaded limits (1000 fps apart). Current velocity is indicated by a moving triangle. A tick mark indicates where MECCO should occur (CO). This scale is active for a nominal ascent or transatlantic abort landing (TAL) abort.
② T	T indicates the throttle command, in percent, generated by the BFS.
③ TMECCO	TMECCO is the predicted time of MECCO, in minutes and seconds, from lift-off.
④ SEP INH	SEP INH is displayed if ET AUTO separation is inhibited.

Figure 2-40. – Concluded.

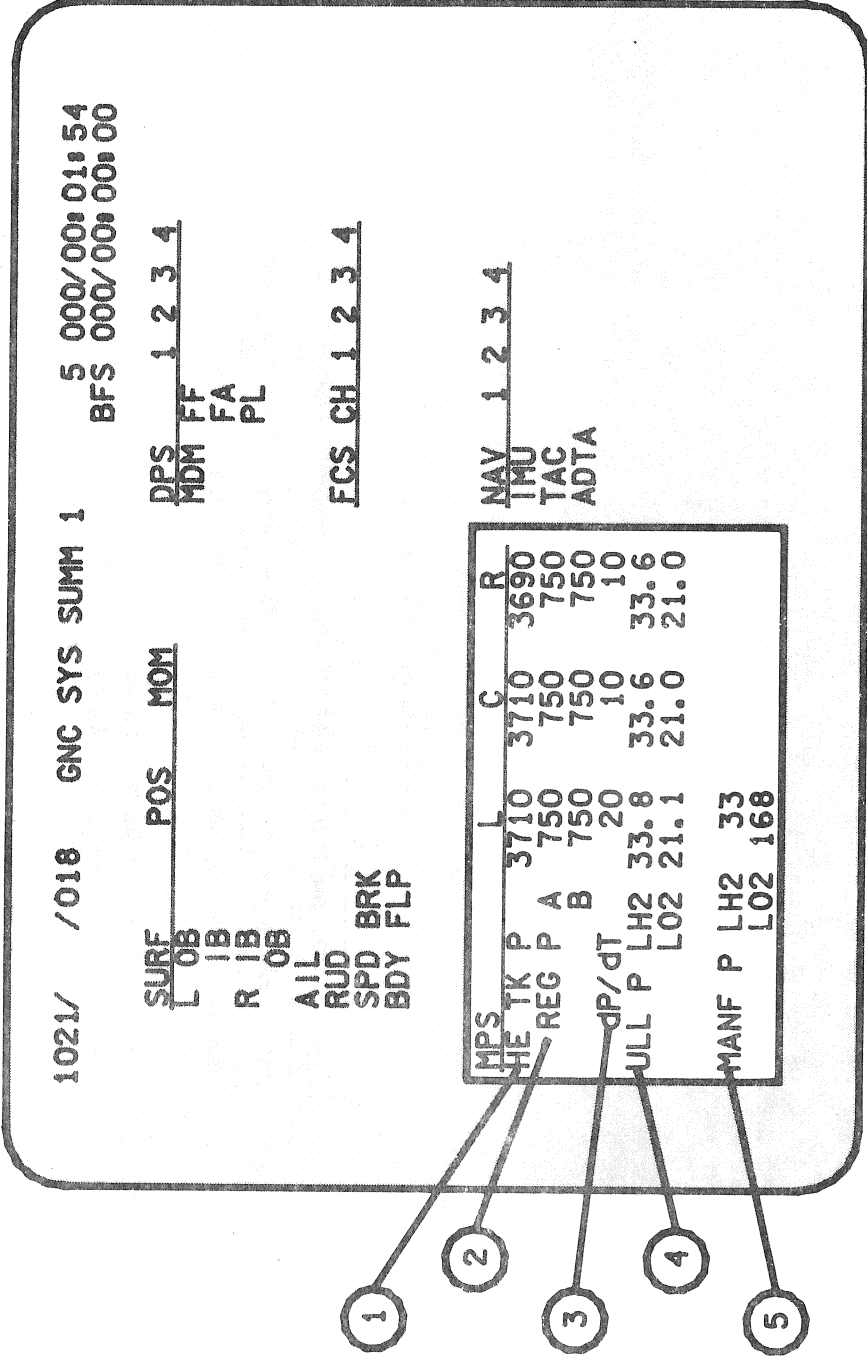

TD3450241. ART 2

Figure 2-41. - BFS GNC SYS SUMM 1 display (DISP 18).

CONTROL OR DISPLAY	FUNCTION
① MPS HE TK P	Displays the left, center, and right helium tank pressures. A ↓ and caution and warning (C&W) alarm are generated if pressure drops to 1150 psi.
② MPS HE REG P A B	Displays the left, center, and right helium regulator A pressures. A ↓ and system management (SM) alert are generated if pressure drops to 679 psi. An ↑ and SM alert are generated if pressure increases to 806 psi. A C&W alarm sounds if pressure drops to 680 psi or increases to 810 psi. Same as REG A except there is no C&W alarm associated with the B regulators.
③ MPS HE dP/dT	Displays flow rates, in psi per 3 seconds, from the left, center, and right helium tanks. Nominal flow rate is ~12 psi per 3 seconds but, since the display reads only in multiples of 10, the nominal reading is 10. An ↑ and SM alert are generated if dP/dT exceeds 20.
④ MPS ULL P LH2 LO2	Displays ullage pressure from the three active sensors in the LH2 tank. A ↓ and SM alert are generated if pressure drops to 31.6 psi. An ↑ and SM alert are generated if pressure increases to 46 psi. Displays ullage pressure from the three active sensors in the LO2 tank. A ↓ and SM alert are generated if pressure drops to 0. An ↑ and SM alert are generated if pressure increases to 29 psi.
⑤ MPS MANF P LH2 LO2	Displays pressure in the LH2 feedline manifold. An ↑ and C&W alarm are generated if pressure increases to 60 psi. Displays pressure in the LO2 feedline manifold. An ↑ and C&W alarm are generated if pressure increases to 249 psi.

Figure 2-41 -- Concluded.

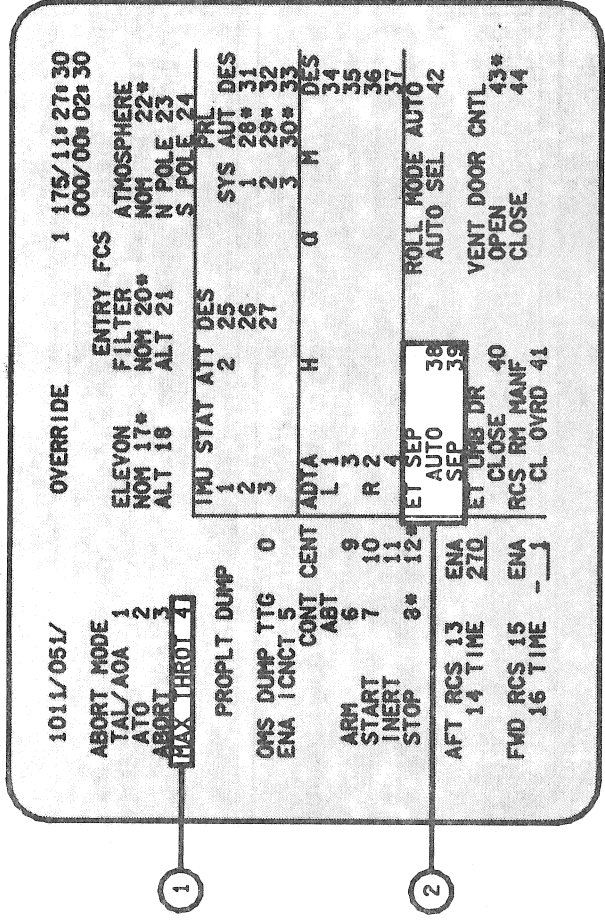

TD3450242. ART. 1

CONTROL OR DISPLAY	FUNCTION
① MAX THROT	Item 4 changes the maximum main engine throttle setting and rescales the speedbrake/thrust controller (SBTC) to the new level. Execution of item 4 in MM 103 and MM 601, before powered pitch around (PPA), commands the new maximum throttle setting. In MM 102 and MM 601, after PPA, it enables the new maximum level to be commanded upon engine failure. Once executed, it is latched and an * is displayed next to the item. Item 4 is legal only in MM 102, 103, and 601.
② ET SEP	Items 38 and 39 allow the crew to select the ET SEP AUTO mode or to initiate ET SEP. An * is displayed when either item is selected. Both items are legal only in MM 102, 103, 104, 105, 106, and 601.

Figure 2-42.- PASS OVERRIDE display (SPEC 51).

Questions

1. What are the functions of the SSME low pressure fuel and oxidizer turbopumps?
 - 1.
 - 2.
 - 3.
 - 4.
 - 5.
2. Identify three parts of the main engine where combustion takes place:
 - 1.
 - 2.
 - 3.
 - 4.
 - 5.
3. Identify the five hydraulically actuated valves in a main engine.
 - 1.
 - 2.
 - 3.
 - 4.
 - 5.
4. True or false: In addition to its role as oxidizer, LO2 is also used to cool the main engines.
5. How many command and data paths are there between each main engine controller and its associated EIU?
6. True or false: The ullage pressure system uses MPS helium to pressurize the propellant tanks in the ET.
7. Briefly describe the interface between the center main engine and the Orbiter hydraulic systems.

Answers

1. What are the functions of the SSME low pressure fuel and oxidizer turbopumps?
The low pressure turbopumps boost the propellant pressures to the level required at the inlets to the high pressure turbopumps. This allows storage of the propellants at low pressure in the ET.
 2. Identify three parts of the main engine where combustion takes place.
 1. fuel preburner
 2. oxidizer preburner
 3. main combustion chamber
3. Identify the five hydraulically actuated valves in a main engine
 1. main fuel valve (MFV)
 2. main oxidizer valve (MOV)
 3. fuel preburner oxidizer valve (FPOV)
 4. oxidizer preburner oxidizer valve (OPOV)
 5. chamber coolant valve (CCV)
4. True or false. In addition to its role as oxidizer, LO₂ is also used to cool the main engines.
False. LH₂ is used to cool the main engines.
5. How many command and data paths are there between each main engine controller and its associated EIU?
There are three command paths and two data paths between each controller and its EIU.
 6. True or false. The ullage pressure system uses MPS helium to pressurize the propellant tanks in the ET.
False. The ullage pressure system uses GH₂ and GO₂ from the three main engines to pressurize the LH₂ and LO₂ tanks in the ET.
 7. Briefly describe the interface between the center main engine and the Orbiter hydraulic systems.
The center engine uses hydraulic system 1 to operate its internal valves and hydraulic systems 1 and 3 for TVC. Hydraulic system 1 is primary for the pitch actuator and secondary for yaw; hydraulic system 3 is primary for yaw and secondary for pitch.

Section 3: System Operations

In this section, nominal MPS operations from crew ingress through landing are discussed. Our primary objective is to learn the MPS-related Flight Data File (FDF) procedures and understand their rationale. The procedures discussed in this section can be found in the Ascent and Post Insertion Checklists. Other functions that require little or no crew input, such as the MPS propellant dump, are also described. All events are presented in sequential order and are separated into four mission phases: prelaunch, powered flight, post-MECO, and entry.

Prelaunch

When the crew enters the Orbiter 2 hours prior to lift-off, the MPS is nearly ready for launch. The ET is loaded, and the propellants are being circulated for tank topping and thermal conditioning. All of the MPS switches are positioned for launch except for the He ISOLATION switches on panel R2. They will be reconfigured at T-16 minutes. Also, at T-8 minutes, the ac bus sensors on panel R1 are repositioned in support of the main engines.

The MPS helium reconfiguration transfers control of the helium isolation valves from the ground support equipment to the crew.

At T-16 minutes, the pilot (PLT) takes the seven He ISOLATION switches on panel R2 from GPC to the OPEN position. See figure 3-1. Prior to this time, the helium isolation valves were already opened by the ground support equipment. The purpose of this procedure is to protect the engines from shutting down in flight due to an inadvertent GPC command to close the helium isolation valves.

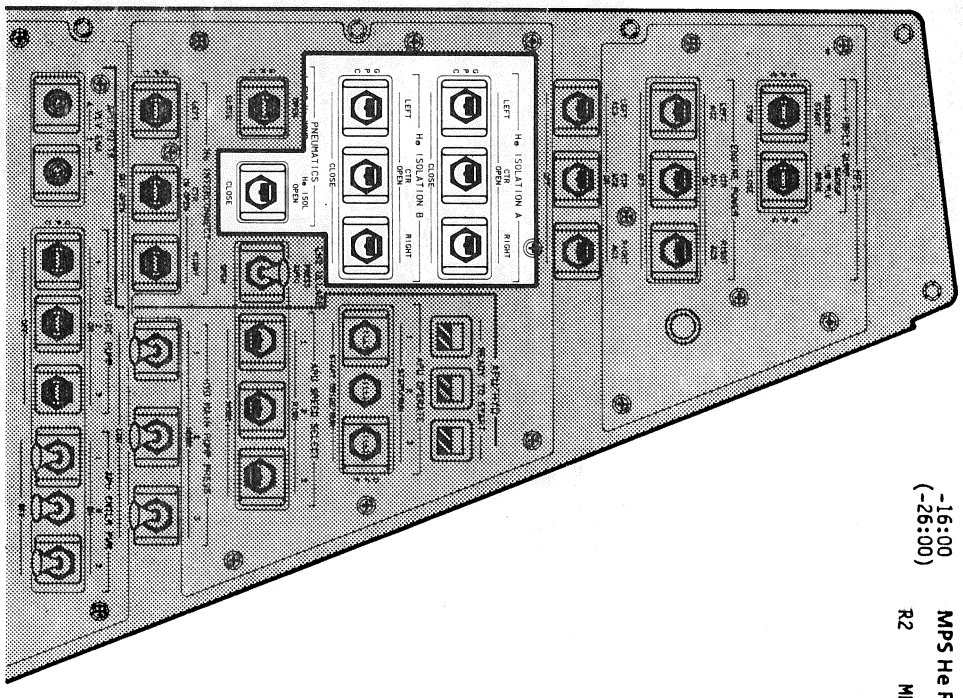
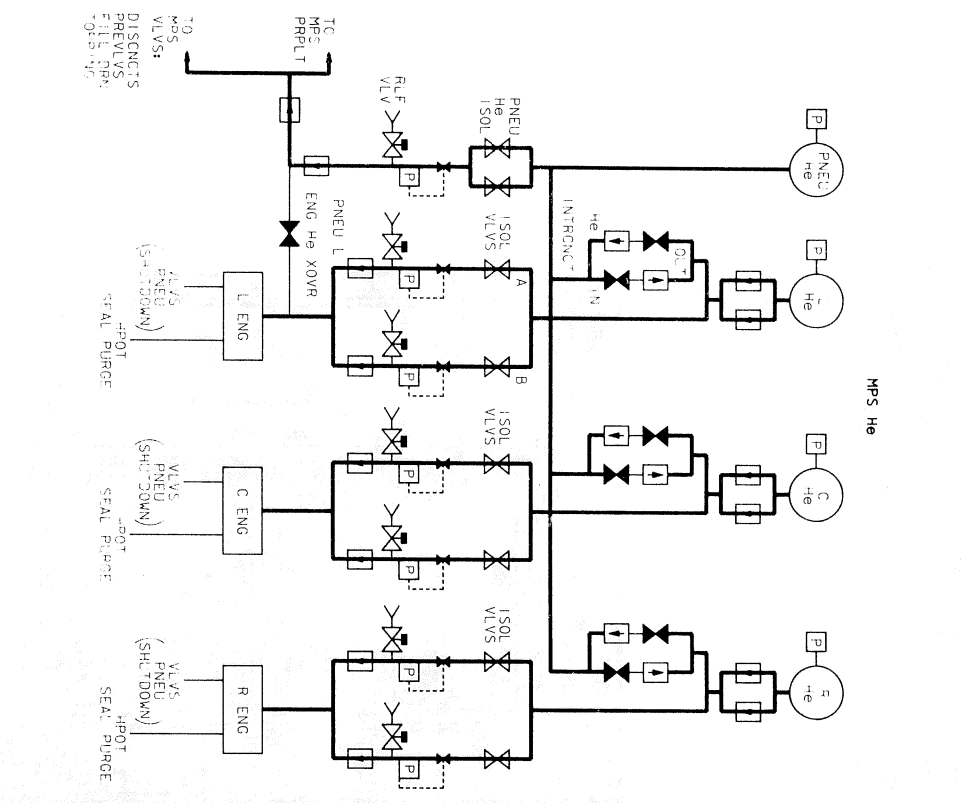

-16:00
 (-26:00)
MPS He RECONFIGURATION
 R2 MPS He ISOL A,B (stx) - OP
 PNEU He ISOL - OP

Figure 3-1. - The MPS He RECONFIGURATION is part of the prelaunch procedures in the Ascent Checklist. The helium system and MPS switches on panel R2 are shown in their launch configuration.

T034R0301, 08715

Power to the main engine controllers is protected by taking the ac bus sensors to MONITOR.

The PLT takes the ac bus sensors, on panel R1, to MONITOR at T-8 minutes. See figure 3-2. These sensors are not part of the MPS, but this procedure is accomplished for the protection of the main engines. Each engine controller is powered by two of the three ac buses, one for each DCU. Therefore, the loss of one bus will

result in a loss of controller redundancy on two engines, and the loss of any two buses will cause the associated engine to shut down. In MONITOR, the ac bus sensors will provide C&W for an over/undervoltage or overload condition, but they will not trip a bus off line.

The remainder of the MPS launch sequence is automatic. Tank topping and thermal conditioning are terminated, and the

propellant tanks are pressurized with ground support helium for engine start. At T-3 minutes, the LO2 tank is pressurized to 21 psig and, at T-2 minutes, the LH2 is pressurized to 42 psig. The main engines are commanded to start at T-7 seconds allowing about 4 seconds for the three chamber pressures to reach 90 percent (a requirement for SRB ignition) and 3 seconds for twang. Twang is the vehicle oscillation that occurs at main engine start. Then, at T-0, the SRBs ignite for lift-off.

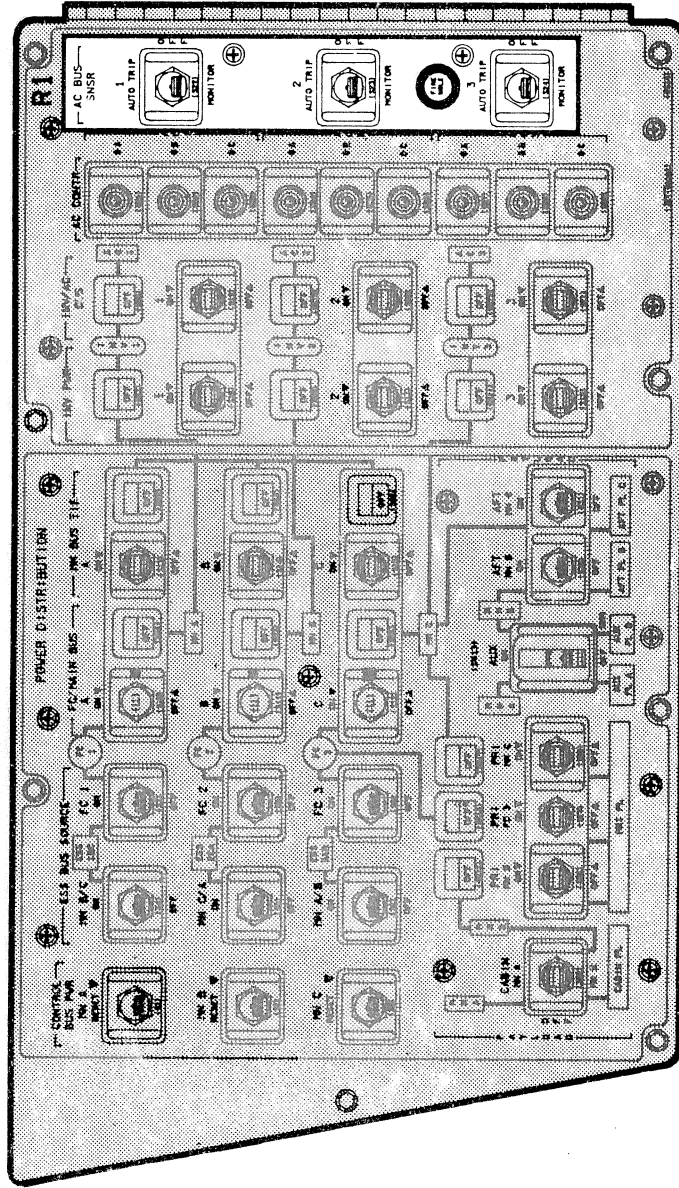

TD3445Z, ART 3

-8:00 P AC SNSR TO MONITOR
 R1 AC BUS SNSR (three) - OFF (1 sec),
 then MONITOR

Figure 3-2.-- The pilot takes the ac bus sensors on panel R1 to MONITOR 8 minutes prior to launch.

Powered Flight

The crew's primary role, during ascent, is one of monitoring.

The crew's workload during ascent has been kept to a minimum. This is especially true for the MPS, which normally requires no crew input during powered flight. The MPS functions that can be monitored include throttle commands; propellant and helium pressures and quantities; and, to some extent, main engine status.

Percent of thrust commanded (T) is displayed on the BFS ASCENT TRAJ display, and actual thrust levels are read on the three Pc meters on panel F7. See figure 3-3.

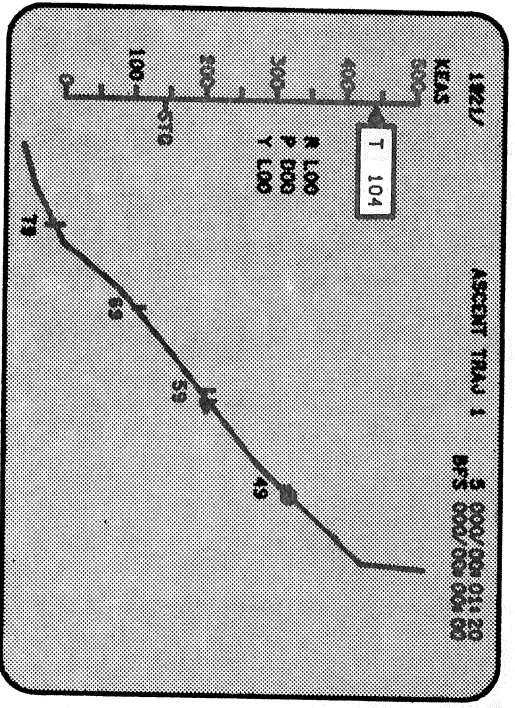
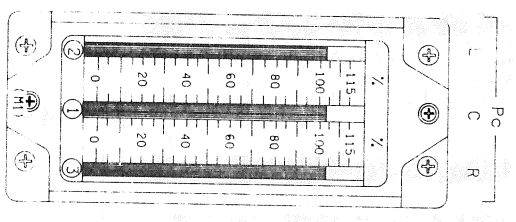

The main engines are commanded to 100 percent for engine start and, shortly after lift-off, to the thrust level required for that flight (normally 104 percent). As dynamic pressure rises, the engines are throttled back to reduce aerodynamic loading. This is called the thrust bucket because of the way the thrust plot appears on a graph. See figure 3-4. Although the bucket duration and thrust level vary with each mission, a typical bucket runs from about 30 to 65 seconds mission elapsed time (MET), during which all three SSMEs throttle back to reduce thrust. The SRB propellant is also shaped to reduce thrust in this region. At approximately 65 seconds MET, the engines are throttled up to the mission required thrust level and remain there until 3g throttling.

The SRBs burn out after about 2 minutes of flight. Appearance of an overbright "Pc < 50" (chamber pressure of the SRBs in psi) on the TRAJ display indicates to the crew that the SRB separation sequence has begun. Actual separation occurs after allowing about 5 seconds for thrust tail-off.

Figure 3-3.—Main engine Pc meters on panel F7 and thrust commanded display on the BFS ASCENT TRAJ 1.

TD3450301, ART 1-4

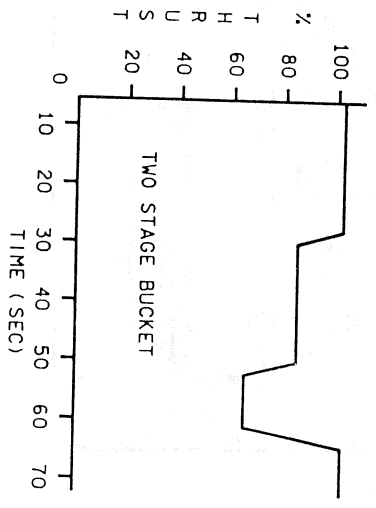
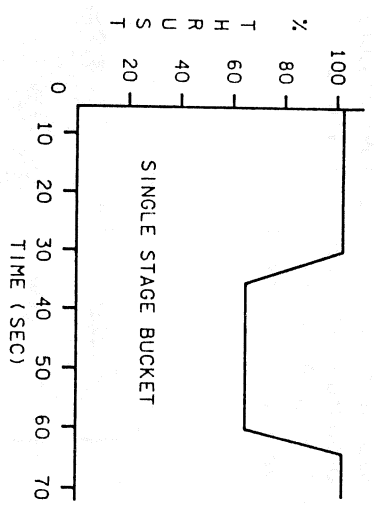
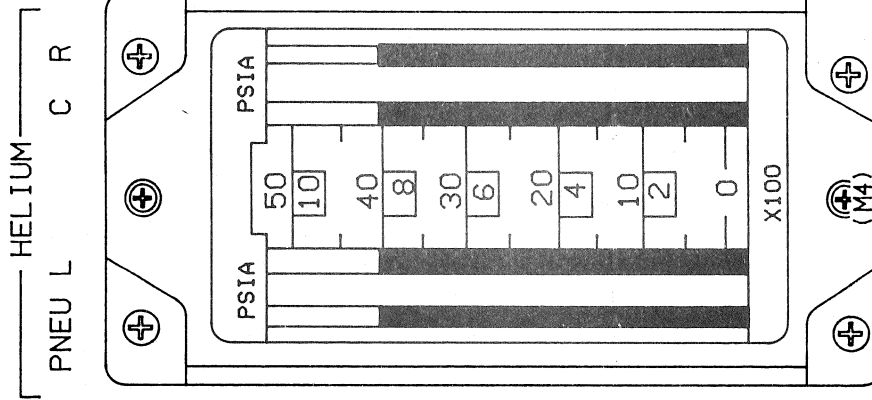
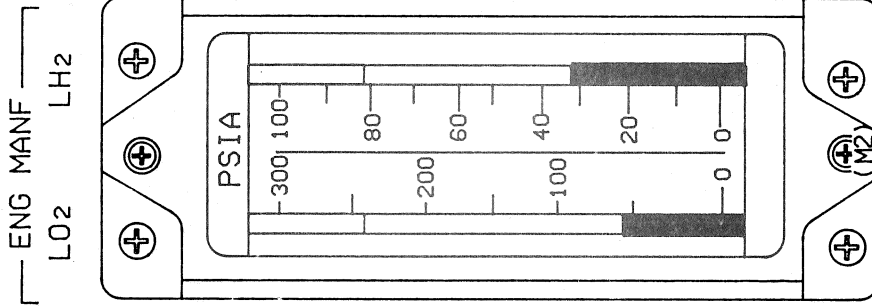
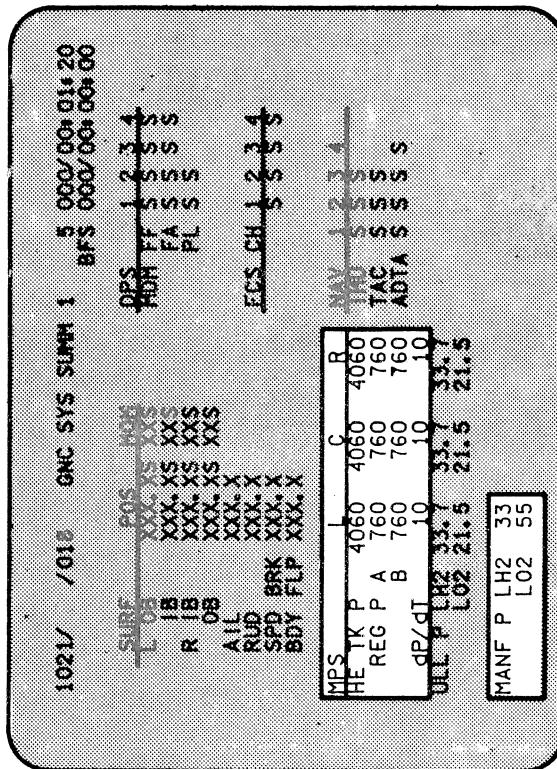

Figure 3-4.—Typical examples of single stage and two stage thrust buckets.

TD3450304, ART 1-2

You can monitor the LO2 and LH2 manifold pressures on the BFS GNC SYS SUMM 1 display and the ENG MANF PRESS meters on panel F7. See figure 3-5.

The LO2 manifold pressure is greatly affected by acceleration from the SRBs. LH2 is not as affected due to its low mass. At SRB separation, the LO2 manifold pressure will drop from well over 100 psia to approximately 50 psia. Pressure rises once again as the vehicle approaches 3g.



TD3450305. ART. 5

Figure 3-5.-- MPS helium and manifold pressures are displayed on the BFS GNC SYS SUMM 1 and panel F7 meters.

MPS helium pressures are displayed on the BFS GNC SYS SUMM 1 display and the MPS PRESS HELIUM meters on panel F7. See figure 3-5.

MPS helium serves two purposes during powered flight. First, it provides a continuous purge of the HPOT seal preventing LO2 in the pump from mixing with hydrogen-rich gas in the turbine. Second, it provides a backup SSME shutdown capability when a normal hydraulic shutdown is unavailable.

When vehicle acceleration approaches 3g, approximately 1 minute before MECO, the engines throttle back to maintain acceleration at 3g or less. The purpose of 3g throttling is to prevent excessive physical stress on the vehicle and crew. Then, 6 seconds prior to MECO, the engines are throttled back to 65 percent in preparation for shutdown.

At approximately 8:30 MET, when the vehicle reaches the required velocity, the GPCs issue shutdown commands to the three main engines. A nominal MECO is effected by the hydraulic closing of the main fuel valve, main oxidizer valve, fuel preburner oxidizer valve, oxidizer preburner oxidizer valve, and chamber coolant valve. Next, the six prevalues are closed to trap propellants in the turbopumps as they wind down, and the feedline relief isolation valves are opened allowing their respective relief valves to operate. The relief valves vent any excess pressure that builds up in the manifolds due to heat soakback from the engines.

In the cockpit, the crew observes MECO through the illumination of three red main engine status lights and three Pc meters driven to 0 percent. See figure 3-6.

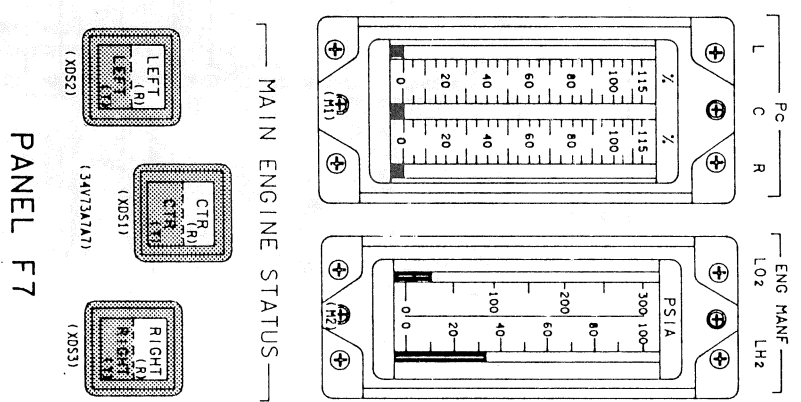
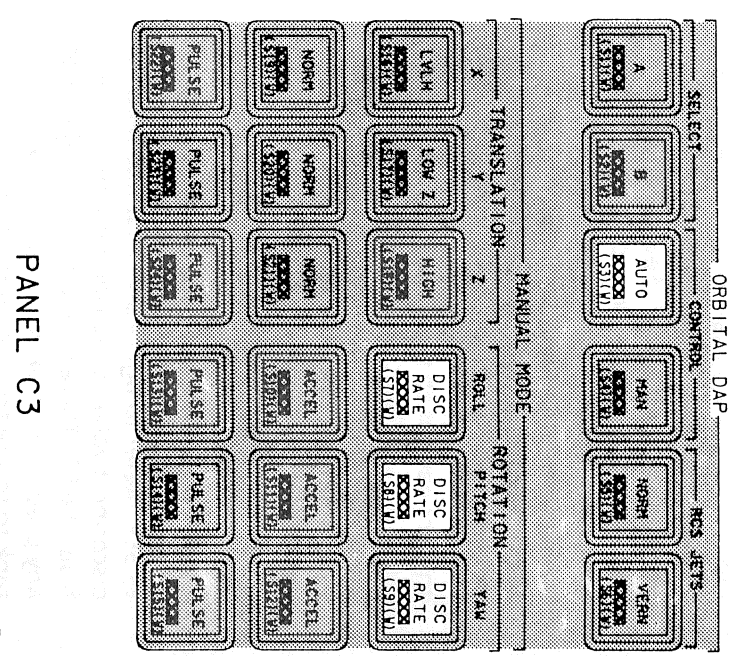

Figure 3-6.—At MECO, the red main engine status lights illuminate and the Pc meters drop to 0 percent. The DAP lights illuminate a few seconds later when the MECO confirmed flag is set.



103450306, ART. 2

Post-MECO

The primary task of the MPS after MECO is to evacuate the approximately 4200 lb of unused propellant trapped in the feedline manifolds.

Propellant evacuation is accomplished through an automatic MPS propellant dump, which is mostly transparent to the crew, and a manual vacuum inerting procedure accomplished by the PLT. Several other functions, discussed later, support the MPS dump and ET SEP.

The first concern after MECO is to verify that the MECO CONFIRMED software flag has been set. This flag is set when the three main engines have been shut down and the prevalues are closed. It marks the end of the SSME operations sequence and allows the ET separation sequence to begin. Illumination of the digital auto pilot (DAP) lights on panel C3 is the first indication that the MECO confirmed flag is set. See figure 3-6.

Three other things occur between MECO and ET SEP. Refer to figure 3-7. First, the feedline disconnect valves close isolating the Orbiter from the ET. This eliminates the possibility of any pressure release which could cause the tank to rotate and recontact the Orbiter after ET SEP. Second, the backup LH2 dump valves are opened for approximately 30 seconds. Since LH2 is more susceptible to expansion from heat soakback than LO2, this function assists the LH2 relief valve in controlling the manifold pressure until the dump is started.

Third, the LH2 bleed valves are opened. When open, these valves allow the LH2 lines inside the engines to be purged during the dump.

Then, 18 seconds after MECO, ET SEP occurs. The main engine bells are then commanded to the stow position.

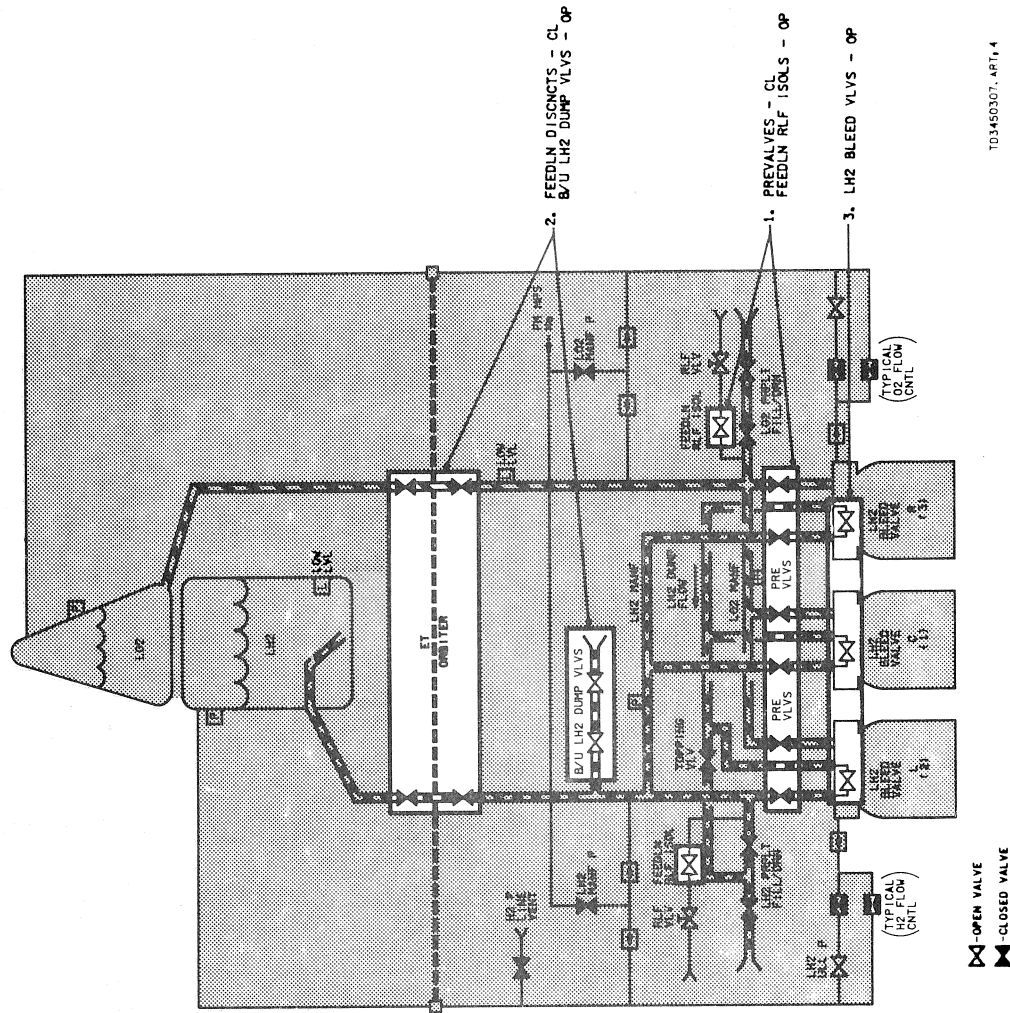

Figure 3-7. - MPS propellant valve sequence (MECO-ET SEP).

At MECO plus 18 seconds, the three main engine status lights extinguish to indicate ET SEP.

The MPS propellant dump is performed after ET SEP to expel the unused LO2 and LH2 remaining in the Orbiter. The dump is required for center of gravity (c.g.) and weight considerations, to preclude spurious venting while onorbit, to prevent corrosion in the propellant lines, and to prevent trapped LH2 from combining with the atmosphere and creating an explosive mixture during entry.

Immediately after ET SEP, the MPS helium system automatically reconfigures to provide helium pressure for the dump. See figure 3-8. The three OUT interconnects open, feeding all the tanks to the common manifold, and the PNEU L ENG He XOVER valve opens to provide a redundant flow of regulated helium. The system is now ready for the simultaneous dump of LO2 and LH2 at OMS-1 ignition.

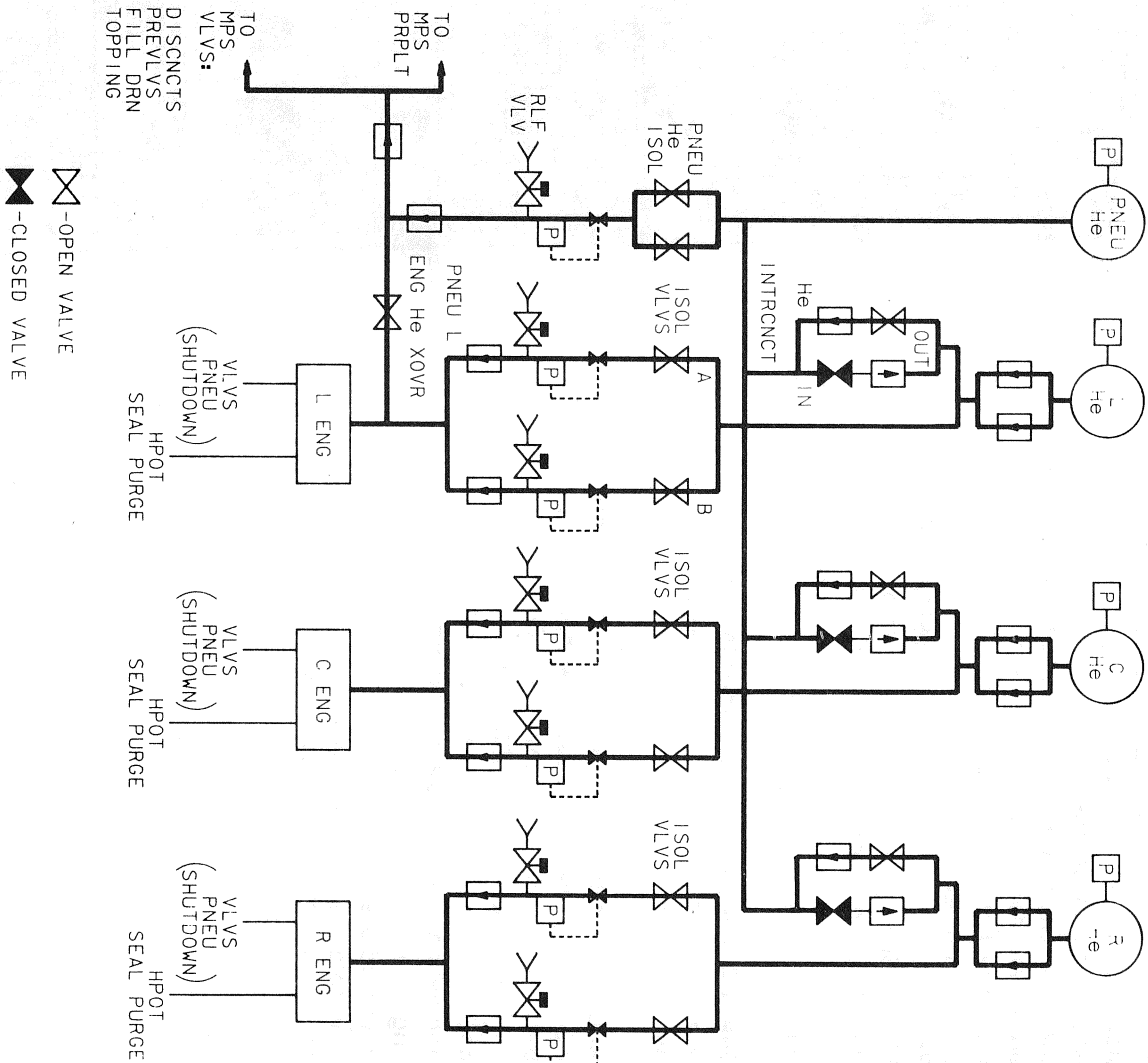
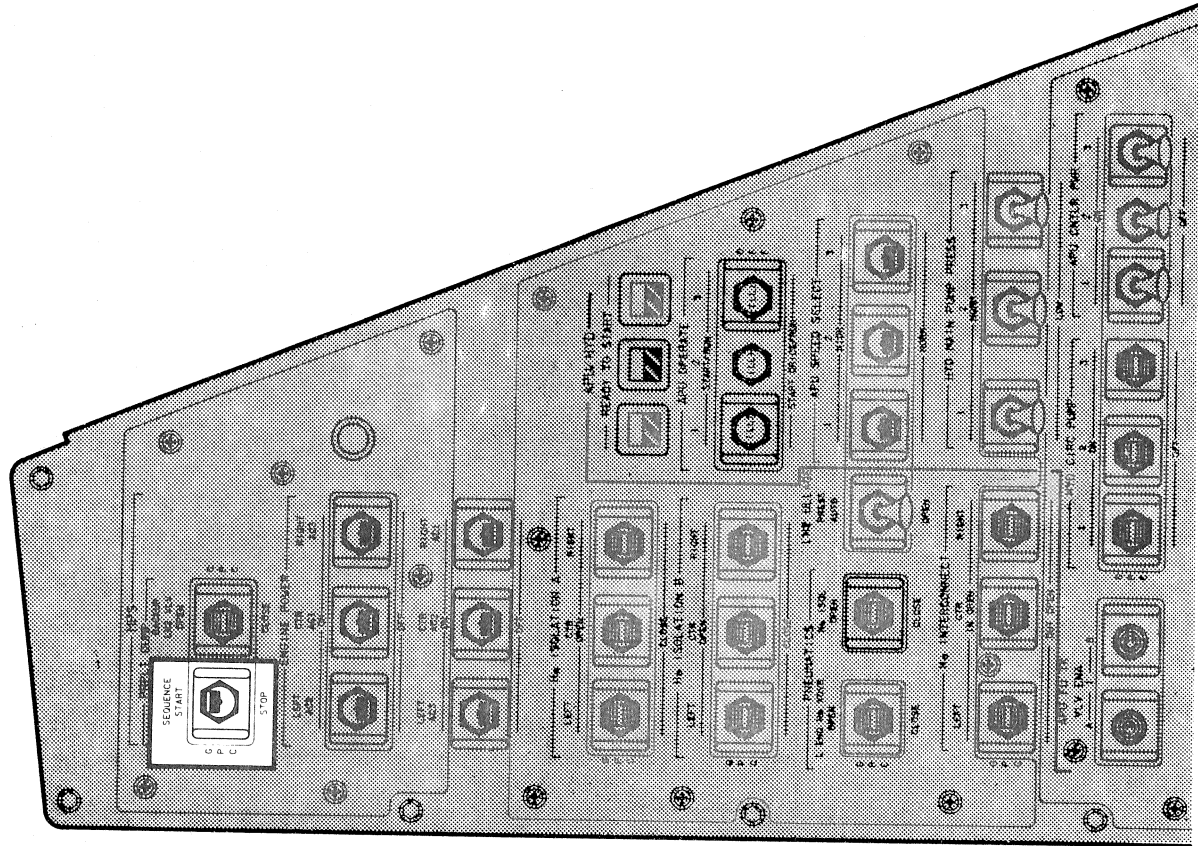

Figure 3-8.- MPS helium reconfiguration prior to the propellant dump.

In a standard insertion flight, the MPS dump is started automatically at OMS-1 ignition. Acceleration from the burn and pressure from the MPS helium system combine to force the propellant out of the lines. If the mission calls for a direct insertion (i.e., no OMS-1 burn), the dump is started manually by taking the MPS PRPLT DUMP switch on panel R2 to SEQUENCE START. See figure 3-9. The acceleration from the OMS burn is replaced by a short + X RCS burn. Once the dump is initiated manually, the remainder of the sequence is automatic.

The LO₂ is dumped through the main engine combustion chambers and out the engine bells. See figure 3-10.

At OMS-1 ignition, the LO₂ manifold pressure valves open releasing pressurized helium into the LO₂ feedline. Also, the three LO₂ prevalves and the three SSME MOVs open; and the LO₂, assisted by vehicle acceleration and helium pressure, is expelled out the main engine bells. After 90 seconds, the LO₂ manifold pressure valves close and the LO₂ manifold is allowed to blow down for another 20 seconds. Then, the MOVs close and the LO₂ dump is complete.



TD3450309, RPT 3

Figure 3-9.-- MPS PRPLT DUMP switch on panel R2.

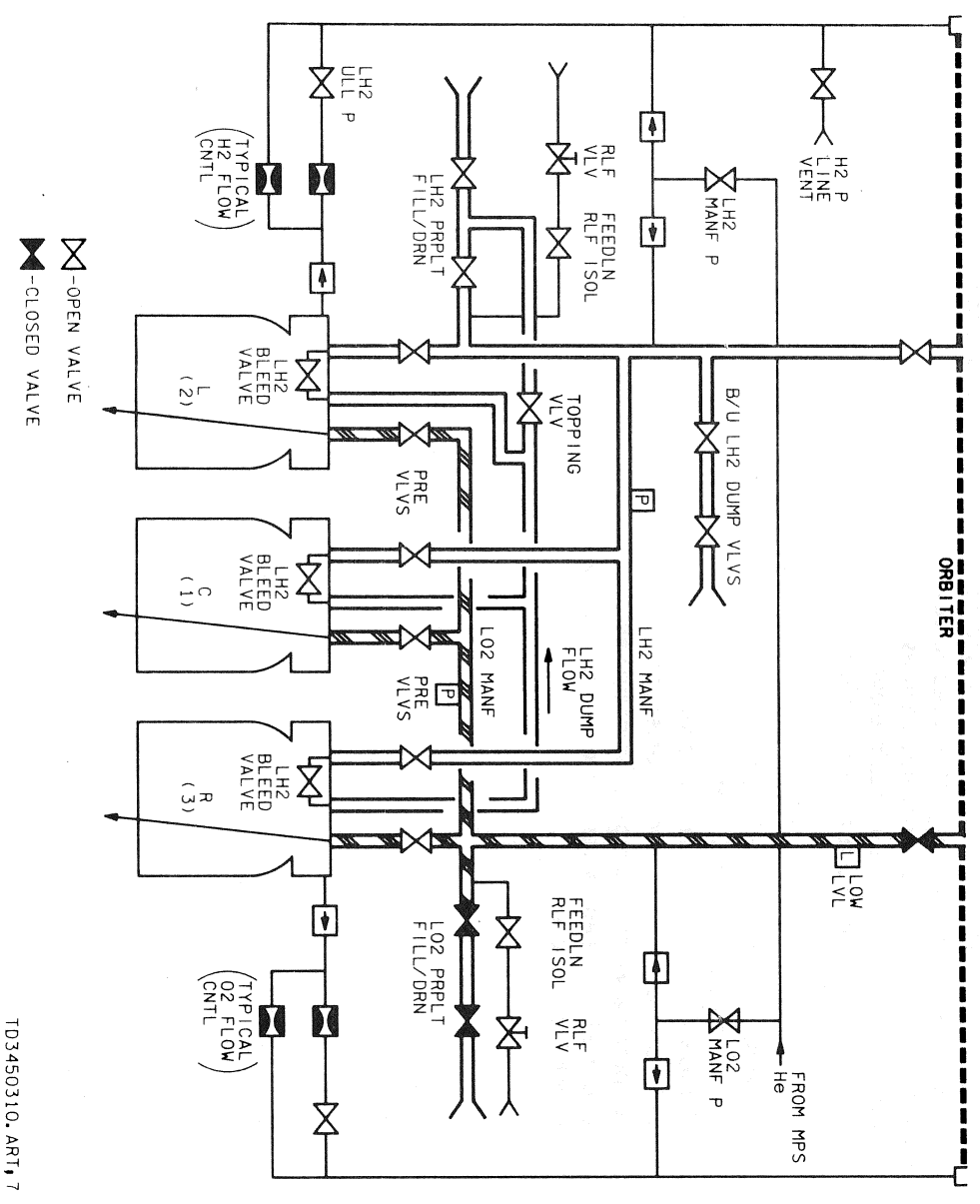

Figure 3-10.-LO2 dump sequence.

TD3450310, ART 1, 7

TD345

TIME	EVENT
0:00	"DUMP START" LO2 MANF P VLV - OP LO2 PREVALVES - OP MOV'S - OP
1:30	LO2 MANF P VLV - CL
2:00	MOV'S - CL "DUMP STOP"

The LH2 is dumped out the left side of the Orbiter through the LH2 fill/drain valves. See figure 3-11.

The LH2 dump is more complex than the LO2 dump and occurs in two distinct stages. At OMS-1 ignition, the LH2 manifold pressure valves and the LH2 outboard and inboard fill/drain valves open. For the first 6 seconds, LH2, aided by acceleration and helium pressure, is dumped out the fill/drain valves. This is part one of the dump.

Part one of the dump allows the LH2 to vent very rapidly and, if allowed to continue, could cause the LH2 to freeze in the overboard line preventing completion of the dump. Also, the recirculation line and the LH2 lines inside the main engines must be purged. Therefore, 6 seconds into the dump, part two begins.

In part two of the LH2 dump, the LH2 inboard fill/drain valve closes and the LH2 topping valve and prevalues open to ensure the LH2 is removed from all the lines. Remember that the three LH2 bleed valves opened shortly after MECO. When the LH2 prevalues open, the flow will continue up to the main fuel valves which remain closed. The LH2 is forced to exit the engines through the bleed valves which empty into the recirculation lines. The recirculation line empties into the overboard line between the LH2 outboard and inboard fill/drain valves.

After 88 seconds, the LH2 manifold pressure valve closes and the LH2 manifold is allowed to blow down for another 32 seconds. Then, 2 minutes after the dump is started, the topping valve, the outboard fill/drain valve, and the LH2 bleed valves all close, and the LH2 dump is complete.

Now that the LH2 and LO2 dumps are complete, the PNEU L ENG HE XOVER valve and the MPS helium interconnect valves are closed.

At 120 seconds after dump start, the body flap lights go out to indicate that the dump sequence is complete.

TIME	EVENT
0:00	"DUMP START" LH2 MANF P VLV - OP LH2 OB FILL/DRAIN - OP LH2 IB FILL/DRAIN - OP
0:06	LH2 IB FILL DRAIN - CL LH2 TOPPING VLV - OP LH2 PREVALVES - OP
1:28	LH2 MANF P VLV - CL
2:00	LH2 TOPPING VLV - CL LH2 OB FILL/DRAIN - CL "DUMP STOP"

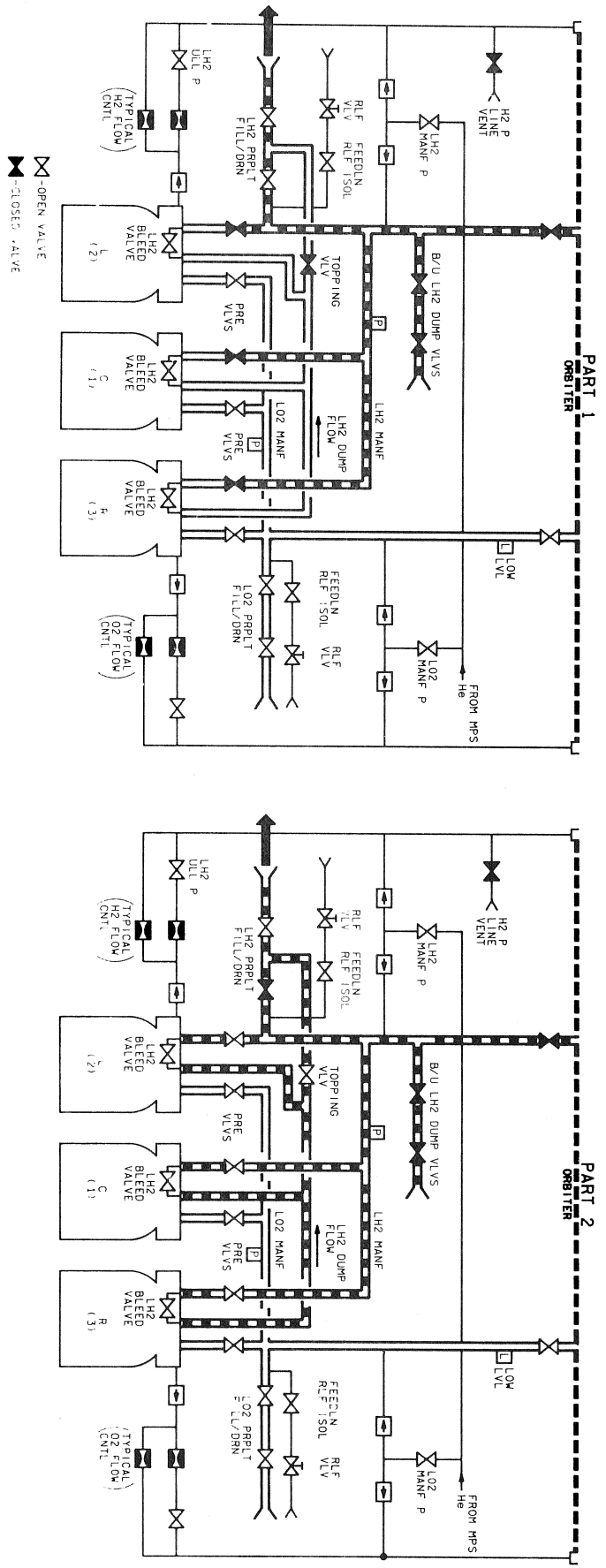

Figure 3-11 - LH2 dump sequence.

The MPS powerdown procedure removes ac power from the main engine controllers and isolates the three main engine helium tank systems.

The PLT accomplishes the MPS powerdown, after the OMS-1 burn, to secure the MPS for orbit operations. See figure 3-12. The six MPS ENGINE POWER switches on panel R2 are taken to OFF, removing all power to the main engine controllers. It is important that this portion of the procedure is not accomplished until after the MPS dump. Once power is removed from the controllers, the main oxidizer valves, which are necessary for the LO2 portion of the dump, can no longer be operated.

The six helium isolation valves are also closed by taking the switches to GPC. This isolates the three main engine helium tanks from the engines. The NOTE after the procedure alerts the crew to expect multiple master alarms as the helium pressure in the now isolated regulators bleeds down. Pressure is normally regulated at 750 psi. A master alarm will annunciate for any of the three A regulators whose pressure drops to 680 psi prior to OPS 2. (B regulators are not used in the C&W system.)

Finally, the PLT is asked to verify that the three He INTERCONNECT switches are in GPC. This ensures the helium interconnect valves are all closed, isolating the left, center, and right helium tanks from the common manifold. The PNEU He ISOL valves are left open for MPS vacuum inerting.

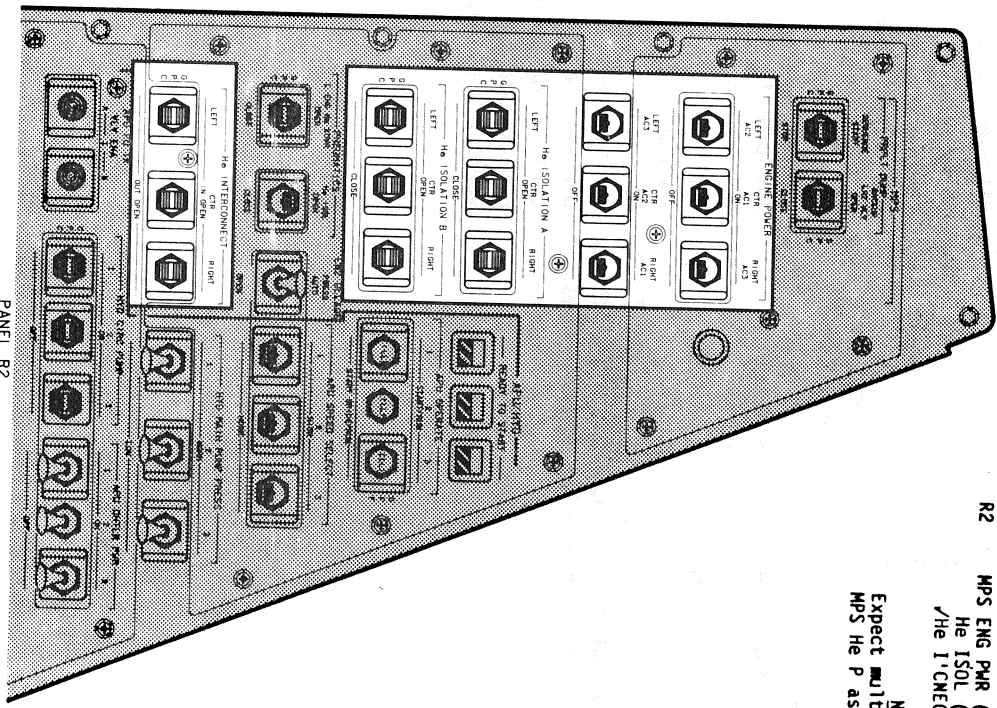
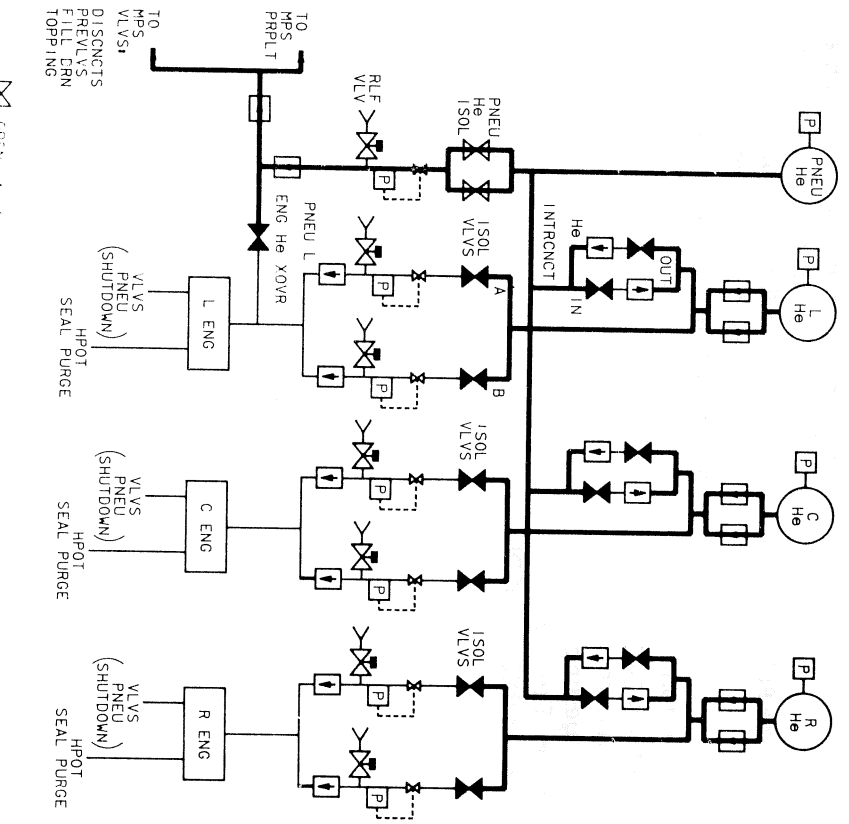

P MPS POWERDOWN

R2 MPS ENG PWR (six) - OFF
He ISOL (six) - GPC
He I'CONNECT (three) - GPC

NOTE
 Expect multiple MAS for
 MPS He P as regs bleed down

Figure 3-12.—The MPS powerdown is accomplished as part of the post-OMS-1 procedures in the Ascent Checklist. When complete, the helium system and panel R2 switches are configured as shown.

103450312, AR 1.5

Vacuum inerting allows any residual traces of LH2 and LO2 trapped in the propellant lines, after the dump, to be vented into space.

The MPS VACUUM INERTING ACT is found in the Ascent Checklist immediately following MPS POWERDOWN. Refer to figure 3-13. The PLT uses pneumatic helium to activate valves that open the propellant manifolds to space. This prevents any overpressure that might burst the lines and precludes intermittent venting which could impact vehicle attitude or contaminate experiments.

When accomplishing this procedure, the PLT first verifies that helium pressure is available to operate the pneumatically actuated valves.

The PLT then opens the MPS H2 PRESS LINE VENT for 1 minute to inert the GH2 pressurization manifold. This is an electrically actuated valve that is spring-loaded to the CLOSE position when power is removed. Finally, to initiate the major portion of vacuum inerting, the PLT manually opens the LH2 and LO2 outboard and inboard fill/drain valves.

Just prior to the OMS-2 burn, the PLT terminates vacuum inerting.

Vacuum inerting is normally performed for 15 to 30 minutes and is terminated 5 minutes prior to OMS-2. Termination is necessary to prevent the open lines from ingesting contaminants during the burn. The LH2 and LO2 outboard fill/drains and the PNEU He ISOL valves are all closed.

At the completion of this procedure, all of the fill/drain switches are left in the GND position to conserve electrical power. With the switches in GND, power is removed from the solenoids used to open and close the valves. Pneumatic pressure will maintain the valves in their last commanded position.

The final step is to close the pneumatic helium isolation valves by taking the MPS PNEU He ISOL switch to GPC. This action isolates the last segment of the MPS helium system. The MPS propellant and helium systems are now configured for orbit.

MPS VACUUM INERTING ACT

R2	/MPS PNEU He ISOL	- OP
R4	MPS H2 PRESS LINE VENT (Start watch) FILL/DRAIN LH2 OUTBD INBD LO2 OUTBD INBD	- OP - OP - OP - OP

After 1 minute:
MPS H2 PRESS LINE VENT - GND

TIG-5

P VACUUM INERTING TERMINATE

R4	MPS FILL/DRAIN LH2, LO2 OUTBD (two) Wait 10 sec LH2, LO2 INBD (two)	- CL - GND - GND
R2	MPS PNEU He ISOL	- GPC

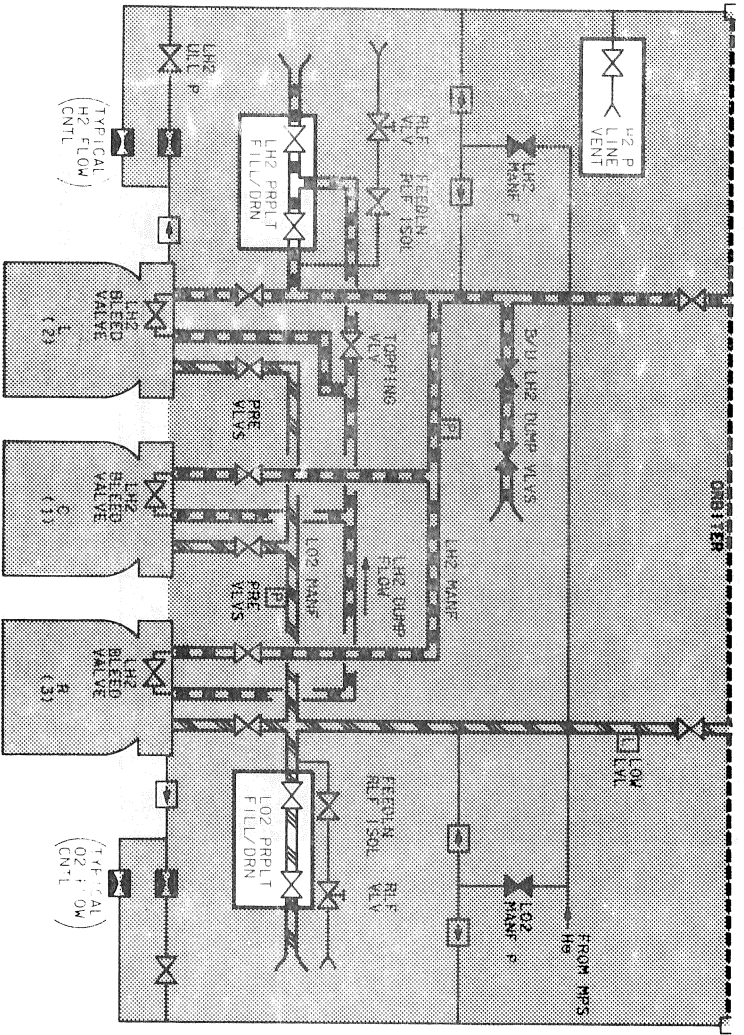

- OPEN VALVE
 - CLOSED VALVE

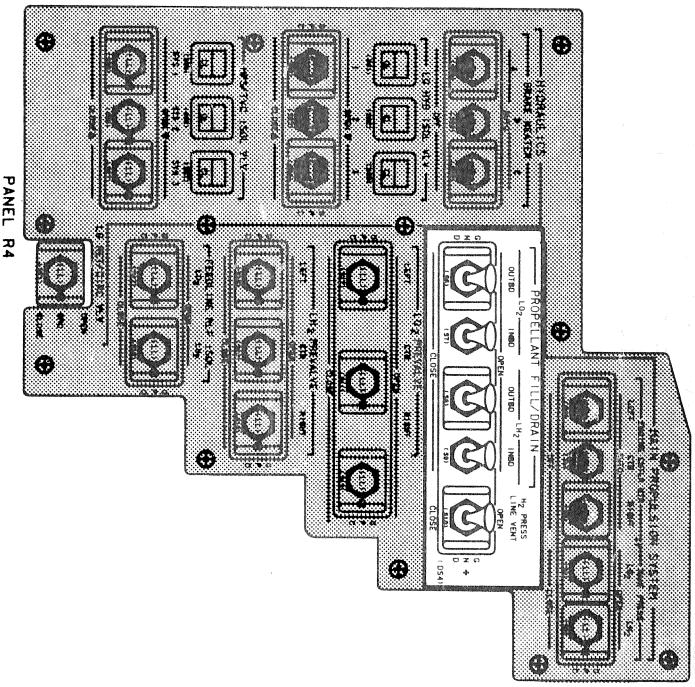
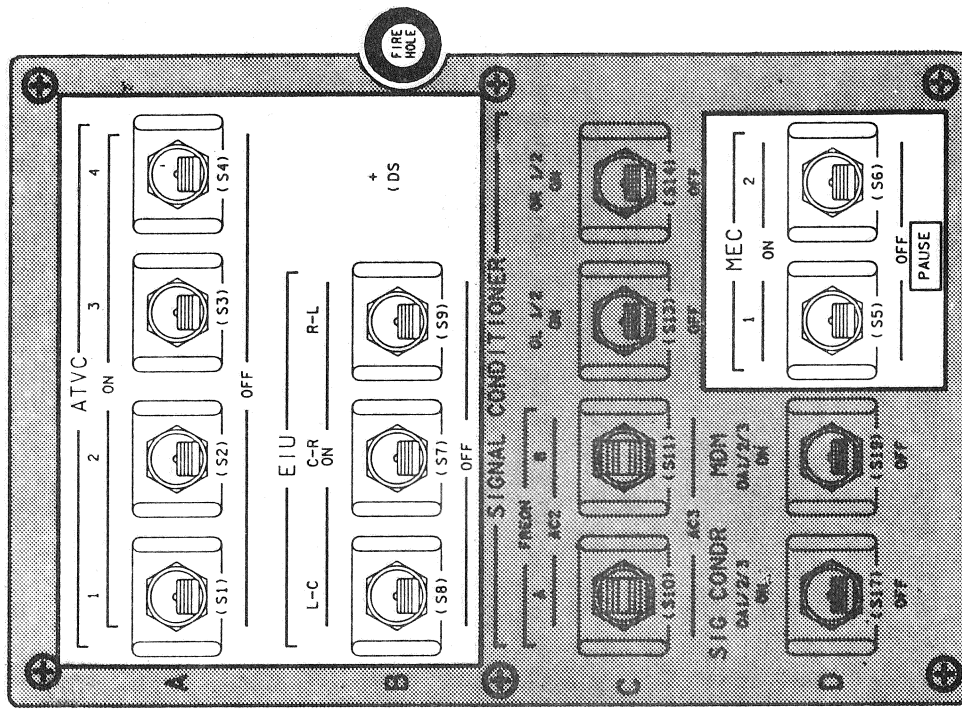

Figure 3-13. - MPS vacuum inerting is started after the MPS powerdown and terminated 5 minutes prior to the OMS-2 burn.

The last procedure required to secure the MPS for orbit operations is found in the Post Insertion Checklist. See figure 3-14. The panel 017 reconfiguration (found in the AFT STATION CONFIG block) removes power from the four ATVC channels, the three EIUs, and the two MECs. The 2-second delay between MECs ensures that spurious shutdown signals cannot act as a fire command to any pyrotechnic devices.

The EIUs and MECs will remain off for the remainder of the mission. Prior to entry, the ATVCs are turned on again to reset the main engines in their stow position.



TD3450314. ART. 3

017:A ATVC (four) - OFF
 :B EIU (three) - OFF
 :D MEC 1 - OFF, wait 2 sec, then
 2 - OFF

Figure 3-14.—Panel 017 reconfiguration in the Post Insertion Checklist.

Entry

During entry, the main propulsion system accomplishes three automatic functions: propellant line inerting, propellant line repressurization, and an H2 purge.

LH2 inerting, through the fill/drain valves and prevalues, is initiated at the transition to MM 304. LO2 inerting is delayed until Mach 20 when the aerosurfaces have enough control authority to override the thrust generated by escaping LO2. The OPS 3 inerting is designed primarily for a TAL where substantial propellant residues are likely due to an abbreviated MPS dump. The helium system is also configured in preparation for the purge and repressurization at this time. See figure 3-15.

When $V_{rel} = 4500$ fps, the LH2 and LO2 outboard fill/drain valves and the LO2 prevalues are closed to terminate inerting. Also, MPS helium is used to pressurize the propellant lines and accomplish an H2 purge. The LH2 and LO2 propellant lines are pressurized to prevent atmospheric contamination, eliminating the need for a lengthy cleanup prior to the next flight. The two OMS pods, the LH2 ET umbilical cavity, and the aft compartment are purged of any potentially explosive H2 that may have accumulated during the flight. The purge continues through landing.

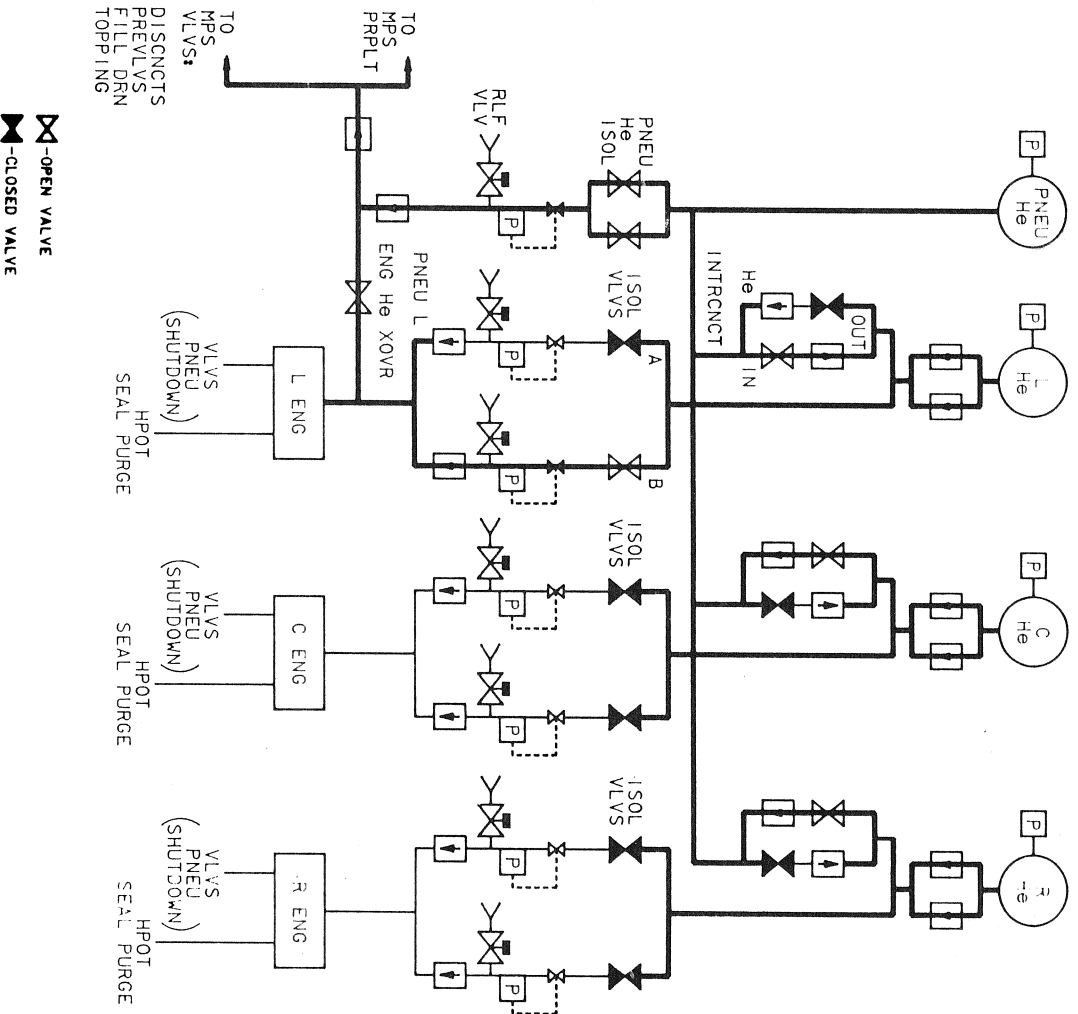

Figure 3-15. - In MM 304, the helium system is automatically reconfigured for the entry purge and repressurization.

This page intentionally left blank.

Questions

1. What visual cue in the cockpit notifies the crew that ET SEP has occurred?
2. What overboard ports are the LH2 and LO2 dumped through during the post-MECO MPS propellant dump?
3. What is the purpose of the MPS vacuum inerting that is performed between the OMS-1 and OMS-2 burns?
4. Why is it important to terminate the MPS vacuum inerting prior to the OMS-2 burn?
5. Why are the MPS propellant lines pressurized during entry?

Answers

1. What visual cue in the cockpit notifies the crew that ET SEP has occurred?
The three main engine status lights on panel F7 extinguish.
2. What overboard ports are the LH2 and LO2 dumped through during the post-MECO MPS propellant dump?
LH2 is dumped out the left side of the Orbiter through the LH2 fill/drain valves, and LO2 is dumped through the main engines.
3. What is the purpose of the MPS vacuum inerting that is performed between the OMS-1 and OMS-2 burns?
Vacuum inerting allows any LH2 and LO2 still remaining in the propellant lines, after the dump, to be vented into space.
4. Why is it important to terminate the MPS vacuum inerting prior to the OMS-2 burn?
Vacuum inerting is terminated prior to the OMS-2 burn to prevent the open lines from ingesting contaminants during the burn.
5. Why are the MPS propellant lines pressurized during entry?
The MPS propellant lines are pressurized during entry to prevent atmospheric contaminants from entering the lines. This eliminates the need for a lengthy cleanup prior to the next flight.

Section 4: System Malfunctions

Most MPS malfunction procedures can be found on three cue cards used by the PLT during ascent. See figure 4-1. The first card, labeled MPS, contains procedures for most engine and propellant related malfunctions. A second card covers MPS helium leaks, and the third addresses problems with ET separation. All malfunction procedures are duplicated in the Ascent/Entry Systems Procedures (MS2 book).

There are no MPS malfunction procedures in the Ascent Pocket Checklist, but it does contain schematics for the MPS propellant and helium systems. The Orbit Pocket Checklist contains no schematics, but there is a single malfunction procedure for the MPS C&W alarm. (MPS C&W is also the sole MPS procedure in the long form Malfunction Procedures book.) There are no MPS procedures in the Entry Pocket Checklist.

MPS malfunctions are annunciated through a combination of warning lights and tones, cathode-ray tube (CRT) fault messages, and meters. The remainder of this section will discuss the causes of each malfunction, the indications annunciated to the crew, and the appropriate FDF procedures and their rationale.

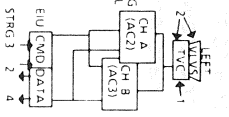
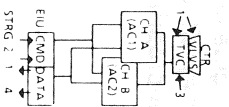
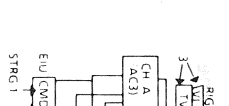
<p>MPS DATA SSME limits automatically inhibited /MCC call</p> <p>No comm: Assume MPS CMD /MCC call</p> <p>MPS CMD HYD or ELEC (Stuck Throttles) 1. If in bucket: ME LIMIT SHUT DN - 1NH 2. If one stage: throttle and 23K (TAL) STAGE 23 SV/RTLS 3P (CO) If MPS CMD SV/RTLS 3P (CO) If MPS CMD SHUTDN (AC/P/B) If MPS HYD or ELEC (AC/P/B) If 1ST STAGE Sep. NOM or If 1ST STAGE Sep. action read If 1ST STAGE per. LOM or (AC/P/B) comm: throttle and 23K; Shut down one eng (AC/P/B) per P1 of CMD (2) HYD (3) ELEC If ENG HYD: SHUTDN ENG (AC/P/B) If ENG ELEC: SHUTDN ENG (AC/P/B) If 2nd CMD at 24.5K 2nd CMD: Man. shutdn (AC/P/B)</p>	<p>MPS</p> <p>LH2 ET ULL PRESS /MCC Post SRB Sep/Pre MECO If 3 of 3 < 31.6: 1. MPS LH2 ULL PRESS - OP When 3 of 3 > 34.5 - AUTO. If 2 of 3 > 34 & third < 31.6: 2. MPS LH2 ULL PRESS - OP When third > 34.5 - AUTO</p> <p>POST MECO LH2 MANF PRESS HIGH If MANF P LH2 > 60: MPS PRPLT dump seq-start ASAP LOZ MANF PRESS HIGH If MANF P LOZ > 249: MPS PRPLT dump seq-start ASAP AESP-11a/A/A</p>
<p>MULTI MPS CMD/DATA (No MECO Confirm) Post MECO: 1NH ENG SHUTDN pb (three) - push (stimo) ENGFALL AC BUS SNSR (three) - OFF If MPS Data: 1NH ENG SHUTDN pb - push If second failure: ME LIMIT SHUTDN - 1NH</p> 	 

MPS He TK LK Pre ET SEP

If He REG P + or +:
1. Affected He ISOL-CL
Otherwise:
2. He ISOL A - CL
If no decr in dp/dt:
3. He ISOL A - OP
B - CL

No decr in dp/dt:
4. He ISOL B - OP
If TK P < 1100:
5. Affected He I'CONNECT - IN OP
At ET SEP:
6. He I'CONNECT - GPC >>

MPS He TK LK Post ET SEP (Not RTLS)

If TK P < 1100:
1. Affected He ISOL (two) - CL
If second TK P < 1100 (not TAL):
2. PNEU He ISOL - CL
ALL VER/A/BAS

'ET SEP MAN' [G51] ET SEP
Post MECO:
ET SEP AUTO - ITEM 38 EXEC
To override ET 'SEP INH':
ET SEP SEP - ITEM 39 EXEC

Figure 4-1.- The three MPS malfunction cue cards.

MPS Data

A data path failure is the loss of both the primary and secondary data paths from an engine. This blinds the GPCs and crew to the status of that engine.

Refer to figure 4-2. Primary data is output from the main engine controller through VIE channel A and enters the EIU through CIA 1. It is then output from the EIU through MIA 1. Secondary data is output from the controller through VIE channel B, enters the EIU through CIA 2, and exits the EIU through MIA 4. After leaving the EIU, data travels over its assigned flight-critical data bus to the GPCs. A data path failure results from any combination of failures that interrupts both the primary and secondary data flow from the controller to the GPCs.

The indications of a data path failure include a systems management (SM) alert light and tone, an amber engine status light, the engine Pc meter being driven to zero, and an MPS DATA L (C, R) CRT message.

When a data path failure occurs, the crew checks with Mission Control Center (MCC) to verify that the engine is still running and there are no hidden failures. See figure 4-3.

MCC uses data that does not go through the controller to determine engine status. GH2 outlet pressure, for example, can tell them if the SSME is operating and if it is accepting GPC commands to throttle. If it is determined that the engine is running normally, no other action is required. But if MCC detects an engine failure or a command path failure, they will direct the crew to accomplish the appropriate cue card procedure.

If there is no communication with MCC, assume that the engine also has a command path failure. Since the failure of an engine to accept a MECO command can lead to uncontained damage, the safe thing to do is accomplish the MPS CMD procedures and shut down the engine manually prior to MECO.

When an engine has a data path failure, the redline shutdown limits on the other engines are automatically inhibited. If MCC determines that all three SSMEs are operating, they will direct the crew to reenable limits with the limit shutdown switch on panel C3.

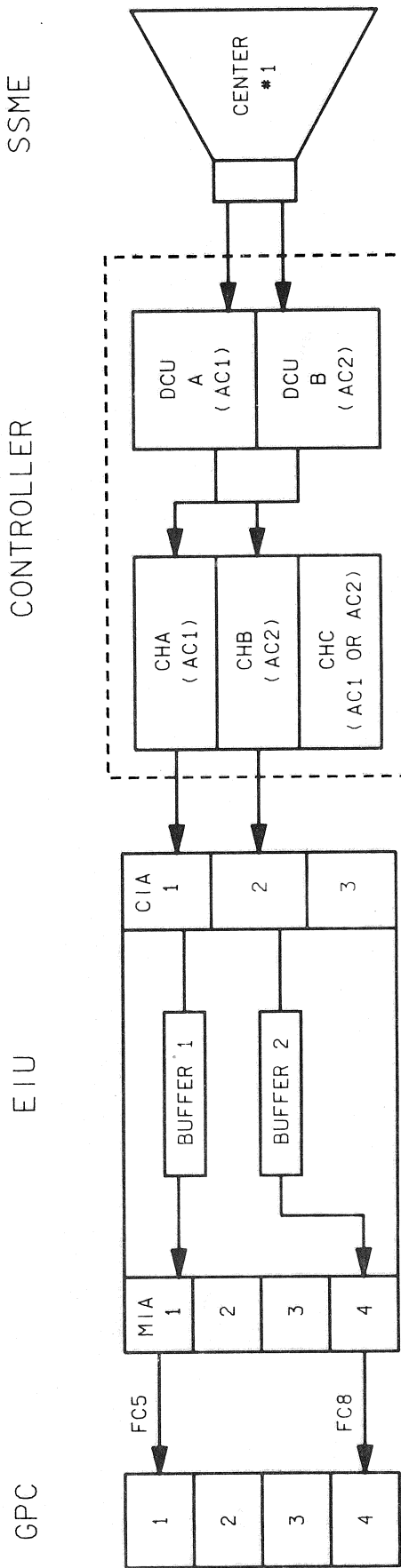
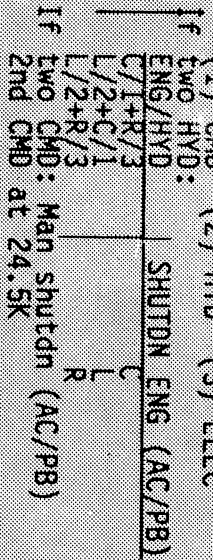

Figure 4-2.— Typical main engine data path flow (center engine). A data path failure results when both paths are interrupted.

MPS DATA
 SSME limits automati-
 cally inhibited
 /MCC
 NO comm: Assume MPS CMD

MPS CMD, HYD or ELEC (Stuck Throttles)
 1. If in bucket: ME LIMIT SHUT DN - INH
 If one stuck throttle and > 23K
 (TAL > 22.5K/RTLS:AR = C0)
 If MPS CMD & no MCC comm:
 Man eng shutdn (AC/PB)
 If MPS HYD or ELEC:
 If 1st Stage Perf NOM or
 RTLS/TAL: No action reqd
 If 1st Stage Perf LOW or no
 comm: Man eng shutdn (AC/PB)

3. If two stuck throttles and > 23K:
 Shut down one eng (AC/PB) per
 priorities
 (1) CMD (2) HYD (3) ELEC



MPPS

LH2 ET ULL PRESS
 /MCC
 Post SRB SEP/Pre MECO
 If 3 of 3 < 31.6:
 1. MPS LH2 ULL PRESS - OP
 when 3 of 3 > 34.5 - AUTO
 If 2 of 3 > 34 & third < 31.6:
 2. MPS LH2 ULL PRESS - OP
 when third > 34.5 - AUTO

POST MECO
LH2 MANF PRESS HIGH
 If MANF P LH2 > 60:
 MPS PRPLT dump seq-start ASAP
LOZ MANF PRESS HIGH
 If MANF P LOZ > 249:
 MPS PRPLT dump seq-start ASAP
 AESP-11a/A/A

MULTI MPS CMD/DATA
 (NO MECO Confirm)

Post MECO:
 MN ENG SHUTDN pb
 (three) - push (simo)
ENG FAIL
 AC BUS SNSR (three) - OFF
 If MPS Data:
 MN ENG SHUTDN pb - push
 If second failure:
 ME LIMIT SHUTDN - INH

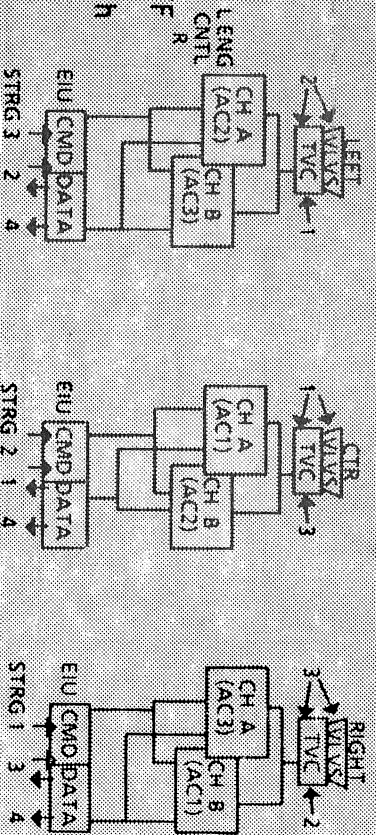

Figure 4-3.-MPS DATA cue card procedure.

Stuck Throttles

An SSME that will no longer throttle is referred to as a stuck throttle. A stuck throttle can be caused by a command path failure, a hydraulic lockup, or an electrical lockup.

A command path failure is the loss of GPC commands to the main engine controller or rejection of the commands by the controller.

Refer to figure 4-4. GPC commands enter the EIU through the four MIAs. Commands that come through MIAs 1 and 2 are sent to CIAs 1 and 2, respectively. Commands that come through MIAs 3 and 4 are sent to CIA 3; the first to arrive is allowed to pass and the other is dead-ended. In this way, the EIU reduces the four commands sent to the EIU to three commands output by the EIU to the controller.

The commands output from CIAs 1, 2, and 3 are received by the controller through VIE channels A, B, and C, respectively. A command path failure results when two of the three commands fail to reach the controller or when the controller rejects the commands due to transmission errors.

The indications of a command path failure include an SM alert light and tone, an amber engine status light, no change in the Pc meter during throttling, and an MPS CMD L (C, R) CRT message.

A hydraulic lockup occurs when any of the five hydraulically actuated engine valves fails to achieve its commanded position.

Main engine throttling is accomplished by modulating five hydraulically actuated valves within the engine. See figure 4-5. The five valves are the MFV, MOV, FPOV, OPOV, and CCV. The center, left, and right engine valves are powered by hydraulic systems 1, 2, and 3, respectively. A hydraulic lockup occurs when one or more of the valves fail to respond to a command from the controller. This can be due to a hardware failure in the valve itself or a complete hydraulic system failure.

The indications of a hydraulic lockup are an SM alert light and tone, an amber engine status light, no change in the Pc meter during throttling, and an MPS HYD L (C,R) CRT message.

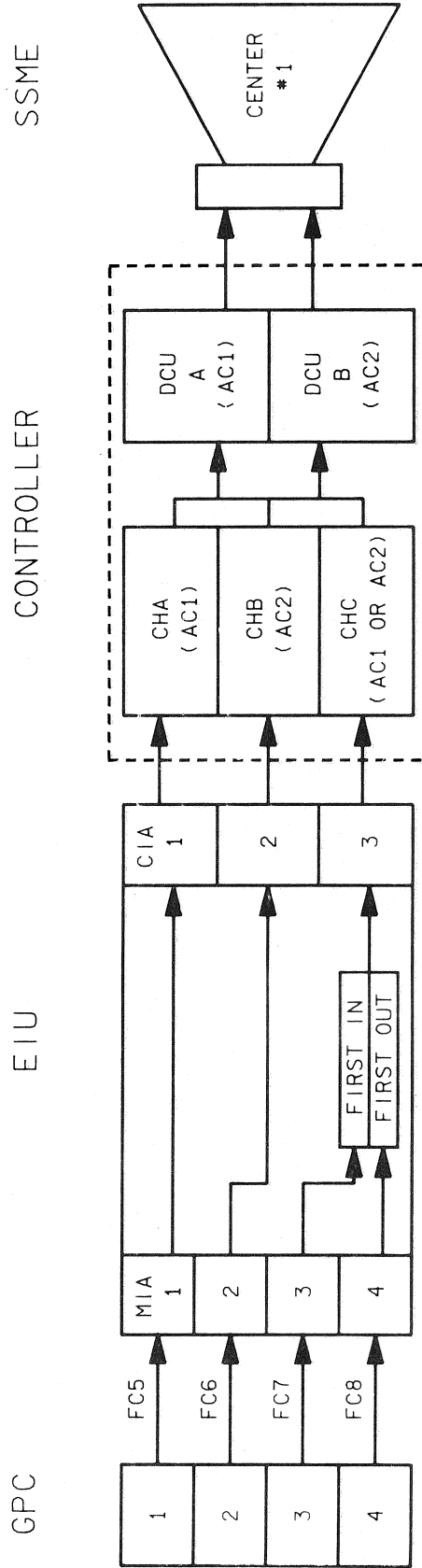

TD3450404. ART, 2

Figure 4-4. - Typical main engine command path flow (center engine).

An electrical lockup occurs when the controller loses all Pc or fuel flow rate data from the engine.

There are four main combustion Pc sensors and four fuel flow rate sensors in each engine. In each case, the sensors are divided into two pairs, one pair for controller DCU A and the other for DCU B. (Oxidizer flow rate is calculated using engine Pc and fuel flow rates.) If both pairs of engine Pc and/or fuel flow rate sensors are lost, the controller can no longer correctly determine engine performance or mixture ratio; so it locks up to maintain the last commanded position.

The indications of an electrical lockup are an SM alert light and tone, an amber engine status light, no change in the Pc meter during throttling, and an MPS ELEC L (C, R) CRT message.

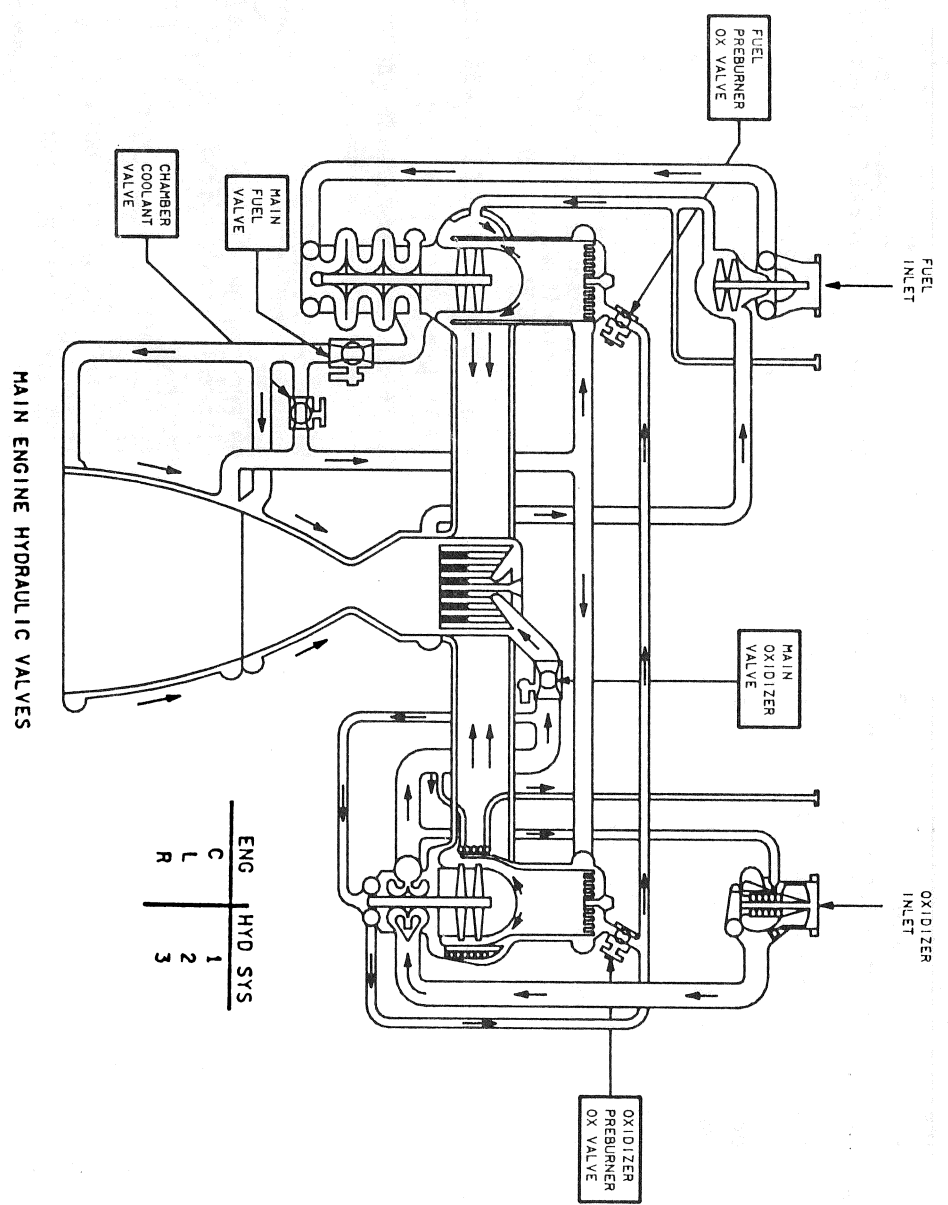

Figure 4-5.- A hydraulic lockup is caused by a valve or hydraulic system failure.

103450405, ART 1, 2

When faced with one stuck throttle, analyze the type of failure and the conditions surrounding it to determine if manual shutdown of the affected engine is required.

Refer to figure 4-6. If a throttle sticks in the bucket, inhibit main engine limits. This is done to prevent one of the good engines from shutting down, which would result in a contingency abort. Later, when intact abort capability with one good engine and one stuck in the bucket is attained, MCC will direct the crew to reenable limits.

MPS DATA
 SSME limits automatically inhibited
 /MCC
 No comm: Assume MPS CMD

MPS CMD, HYD or ELEC (Stuck Throttles)
 1. If in bucket: ME LIMIT SHUT ON - INH
 2. If one stuck throttle and > 23K (TAL > 22.5K/RTLS:AR = CO)
 If MPS CMD & no MCC comm:
 Man eng shudn (AC/PB)
 If MPS HYD or ELEC:
 If 1st Stage Perf NOM or R/TLS/TAL: No action reqd
 If 1st Stage Perf LOW or no comm: Man eng shudn (AC/PB)
 If two stuck throttles and > 23K: Shut down one eng (AC/PB) per priorities
 (1) CMD (2) HYD (3) ELEC
 If ENG/HYD SHUTDN ENG (AC/PB)
 L R
 If two CMD: Man shudn (AC/PB)
 2nd CMD at 24.5K

MPS
LH2 ET ULL PRESS
 /MCC
 Post SRB SEP/Pre MECO
 If 3 of 3 < 31.6:
 1. MPS LH2 ULL PRESS - OP when 3 of 3 > 34.5 - AUTO
 If 2 of 3 > 34 & third < 31.6:
 2. MPS LH2 ULL PRESS - OP when third > 34.5 - AUTO

POST MECO
LH2 MANF PRESS HIGH
 If MANF P LH2 > 60:
 MPS PRPLT dump seq-start ASAP

LO2 MANF PRESS HIGH
 If MANF P LO2 > 249:
 MPS PRPLT dump seq-start ASAP

AESP-11a/A/A

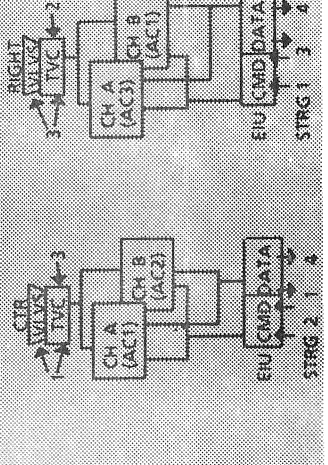
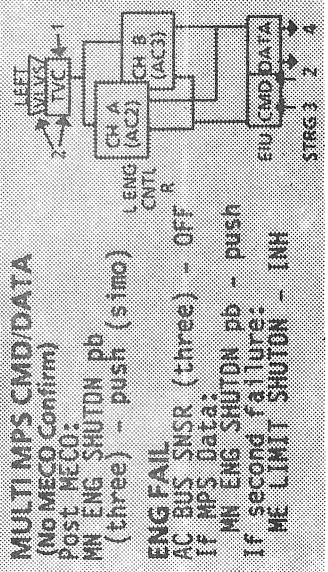

Figure 4-6. - Cue card procedure for one stuck throttle.

If the stuck throttle is a command path failure, the engine will not respond to a GPC MECO command and must be shut down manually. According to step 2 of the cue card procedure, the crew will shut down an engine with a command path failure, using the ac power switches and shutdown pushbutton (AC/PB), when the vehicle velocity is greater than 23K. This allows a shutdown as close to a nominal MECO as possible while still providing a pad against fuel starvation. It also allows guidance enough time to compensate for the lost engine prior to MECO. The shutdown velocity will vary if the crew aborts TAL (22.5K for Dakar) and, for an RTLS, the engine will be shut down at MECO to avoid control problems.

The only way to shut down an engine with a command path failure is with the ac power switches on panel R2. When both switches are turned off, all power is removed from the main engine controller causing a pneumatic shutdown of the engine and creating a data path failure because the GPCs can no longer see any data from the controller. Since the GPCs cannot see the engine as failed, the crew must then depress the corresponding shutdown pushbutton on panel C3 to inform them that the engine is down.

If the stuck throttle is a hydraulic or electrical lockup, the requirements are different. Unlike a command path failure, an engine that is locked up hydraulically or electrically will accept a MECO command from the GPCs. Accordingly, the procedure says that if an MPS HYD or ELEC is displayed and performance is nominal (or RTLS/TAL), no action is required.

But if an MPS HYD or ELEC is displayed and performance is low, shut down the affected engine using the ac power switches and shutdown pushbutton (AC/PB) when vehicle velocity is greater than 23K. The performance call is made by the flight dynamics officer (FDO), after SRB separation. If performance is low, there may not be enough MPS propellant to achieve a nominal MECO and a low-level cutoff could occur. See figure 4-7. Propellant depletion to a running engine could result in a high-pressure turbopump overspeed and uncontained engine damage. Normally, when two of the four LH2 or LO2 low-level sensors go dry, a shutdown timer starts which ensures maximum use of the remaining propellant, while still preventing propellant depletion. But the timer assumes that three engines are shut down from 65 percent.

If one engine is stuck at a higher power level, propellant consumption will be greater than normal when the timer starts, and turbopump cavitation may occur. By shutting down the stuck engine at 23K, the shutdown timer downmodes to the two-engine case, and propellant usage will return to a safe level. This procedure is not required for an RTLS or TAL, because performance in these cases is not normally a problem.

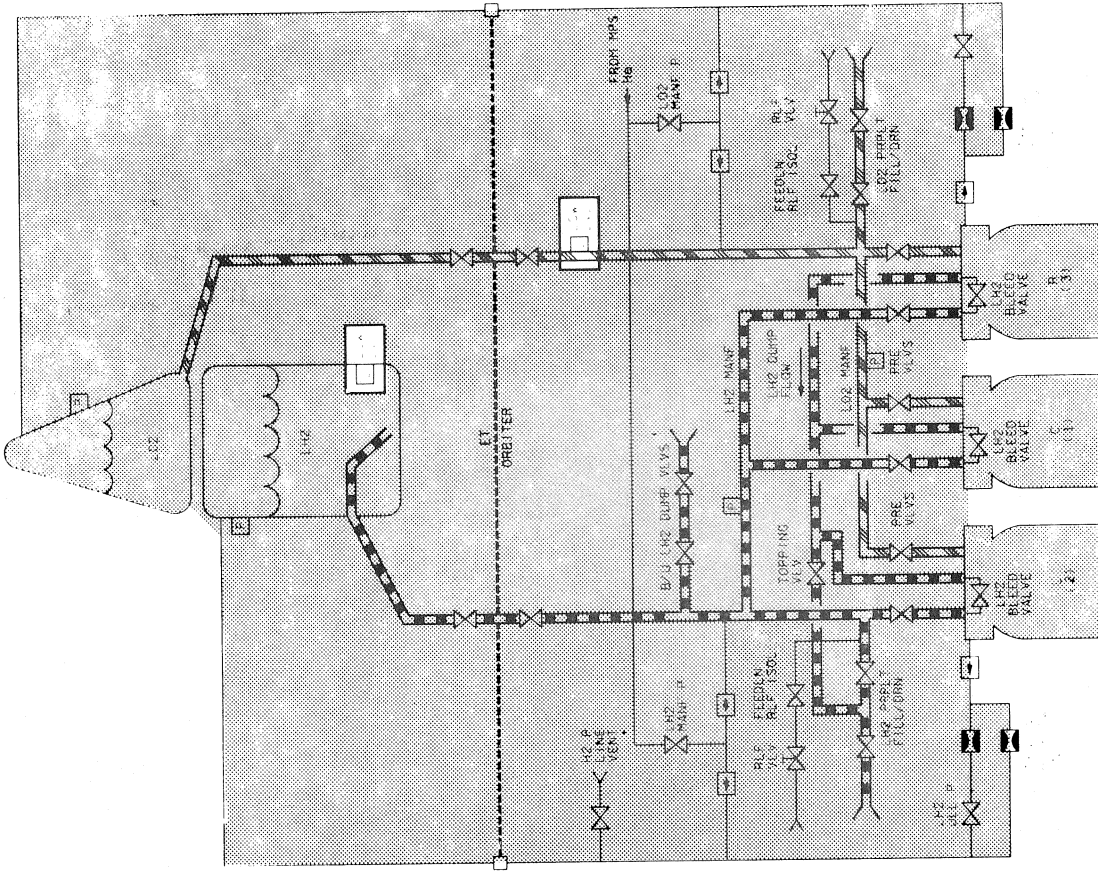

Figure 4-7.- The LH2 low-level sensors are located at the bottom of the tank. LO2 sensors are on the Orbiter side of the LO2 feedline.

When two engines have stuck throttles, one engine must be shut down at 23K to aid 3g throttling.

When the two stuck throttles are different types, shut down one engine according to the priority table on the cue card. Refer to figure 4-8. If one of the stuck throttles is a command path failure and the other is a hydraulic or electrical lockup, shut down the command path with the ac power switches and shutdown pushbutton. This is a logical choice since the command path failure requires a manual shutdown anyway.

If one of the stuck throttles is a hydraulic lockup and the other is electrical, the priority is given to the engine with the hydraulic failure. There are two reasons for this. First, an engine in hydraulic lockup may not run as efficiently as an engine locked up electrically (recall that an electrical lockup is caused by sensor failures). Second, if the electrically locked up engine is shut down manually, you are left with a single-engine LO2 dump since the engine in hydraulic lockup cannot dump and neither can an engine that is shut down with the ac power switches.

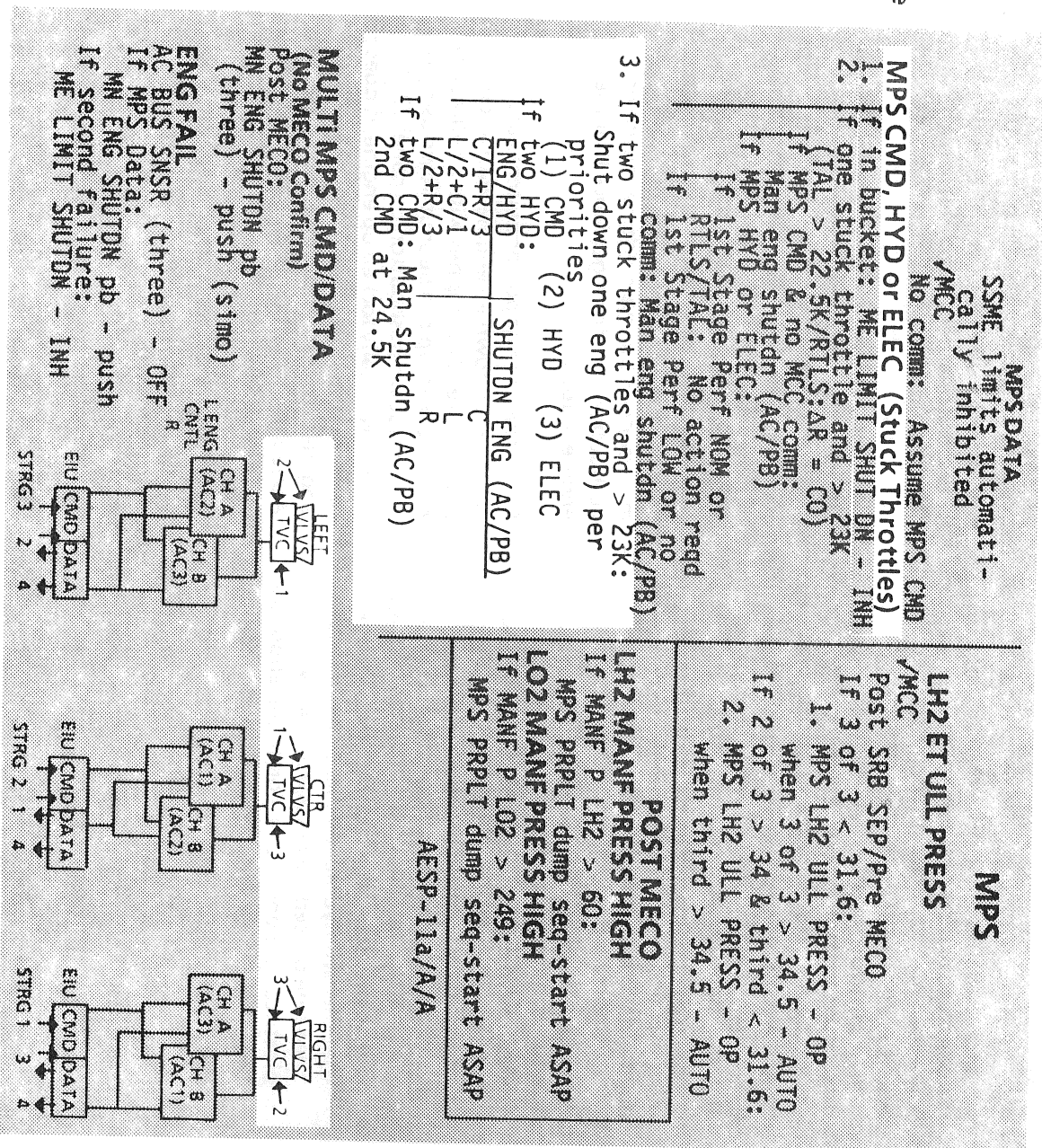

Figure 4-8 - Cue card procedure for two stuck throttles and hydraulic system distribution to the main engine valves and TVC.

If both stuck throttles are hydraulic lockups, use the matrix on the cue card to determine which engine to shut down. For example, if the two lockups are the center engine/hydraulic system 1 and the right engine/hydraulic system 3, shut down the center engine at 23K with the ac power switches and shutdown pushbutton. The rationale behind this procedure is simple. Each engine uses one hydraulic system to power its internal valves and two hydraulic systems to power its TVC actuators. Therefore, loss of any two hydraulic systems will cause stuck throttles on two engines and a loss of TVC on one of those engines. This is the engine to shut down.

In the case of two command path failures, both engines must be shut down manually. Shut the first engine down at 23K to aid 3g throttling and the second one down at 24.5K to avoid shutdown due to propellant starvation. Although there is no preference as to which engine will be shut down first, in a no-communication situation, MCC will assume that the two-hydraulic-failure matrix is used. The same procedure holds true for two electrical lockups and no communication--use the matrix to determine which engine to shut down.

When shutting an engine down manually, each cue card procedure directs the crew to turn off the two ac power switches on panel R2 and then depress the corresponding main engine shutdown pushbutton on panel C3.

Turning off the ac power switches is the most certain way to shut down an engine. This action removes power from the main engine controller resulting in a pneumatic shutdown of the engine. But the power loss to the controller also ends the transmission of data from the engine to the GPCs, resulting in a data path failure. For this reason, the crew must depress the main engine shutdown pushbutton to inform guidance that the engine is down.

Remember, the ac power switches are the only way to shut down an engine with a command path failure. But engines with a hydraulic or electrical lockup can be shut down using only the shutdown pushbutton on panel C3. For the hydraulically locked up engine, it does not really matter how it is shut down because an engine in hydraulic lockup will always receive a pneumatic shutdown. But for the electrically locked up engine, shutting it down using the ac power switches will cause a pneumatic shutdown, whereas depressing the shutdown pushbutton on panel C3 will result in a hydraulic shutdown.

What is the difference between a pneumatic and hydraulic shutdown? The pneumatic shutdown, using the ac power switches, is the most certain way to shut down an engine. But once helium is used to close the five internal engine valves, they cannot be reopened for the remainder of the flight. Since the main oxidizer valve cannot be opened, the MPS LO2 dump capability through that engine is lost. A hydraulic shutdown via the pushbutton on panel C3, however, preserves the dump capability of that engine.

There are two reasons why the MPS cue card always directs crewmembers to shut down an engine with the ac power switches. The first is procedural simplicity. Using the same procedure every time avoids confusion as to which method to use for the failure case. The second reason is the certainty of shutdown. Using the ac power switches will always shut down an engine, but a single MDM comm fault or control bus failure will preclude a manual shutdown with the shutdown pushbutton.

Each main engine shutdown pushbutton is a two-contact switch. See figure 4-9. Each contact is wired through a different control bus and flight forward (FF) MDM. The buttons are used to (1) shut an engine down, (2) inform the GPCs that an engine with a data path failure is down so they can mode guidance and close the prevalves, or (3) set the MECO confirmed flag when required.

When both contacts on a shutdown pushbutton are good, all functions are available. If one contact is good and the MDM associated with the other contact is commfaulted, the crew can no longer command a shutdown but can mode guidance and close the prevalves on a dead engine with a data path failure; that button is also available for setting the MECO confirmed flag.

In the case where one contact is good and the other has a control bus failure, the main engine shutdown pushbutton is useless. Depressing the button will only generate an ME SHDN SW C (L, R) message to indicate a "switch disagree" condition. However, if poor vehicle control mandates that guidance be informed of a dead engine hidden behind a data path failure, the button can be "fooled." Creating a commfault on the bad contact by shutting off the appropriate FF MDM will mask the control bus failure. Now, with one contact good and the other commfaulted, the crew can mode guidance and close the prevalves on a dead engine with a data path failure.

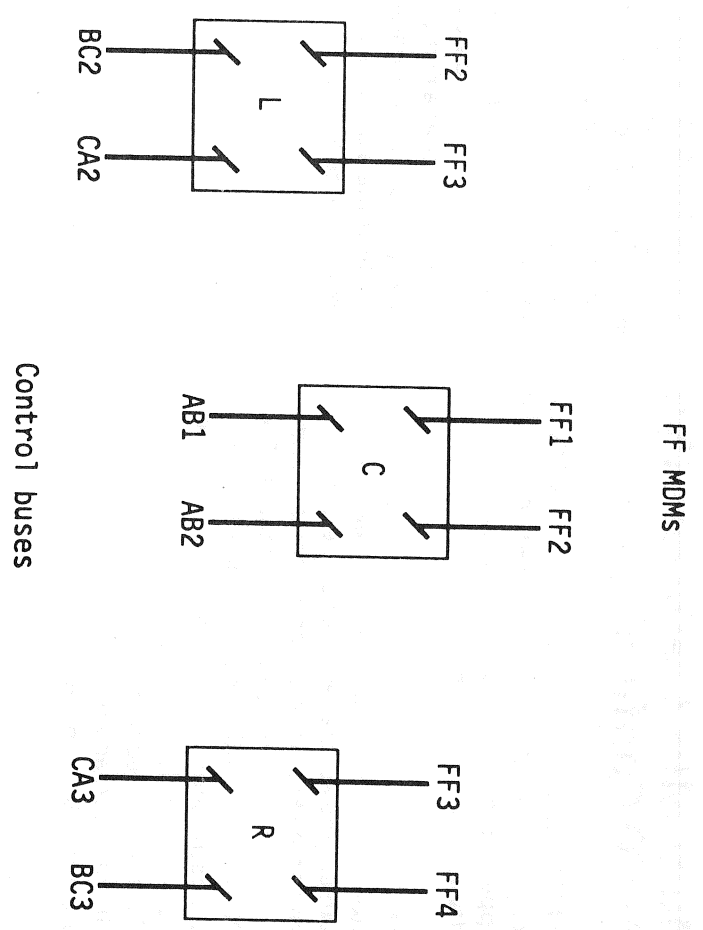

Figure 4-9. – Shutdown pushbutton wiring scheme.

TD345*004

Multi-MPS CMD/Data (No MECO Confirm)

No MECO confirm is the failure of the GPCs to recognize that MECO has occurred. When this happens, the ET will not separate and the software will remain in MM 103.

The MECO confirmed software flag is automatically set when the GPCs see three main engine Pcs are less than 30 percent, or two engine Pcs are less than 30 percent and the third engine has a data path failure. The GPCs cannot see the Pc on an engine with a data path failure. Therefore, if two or more engines have data path failures at MECO, the MECO confirmed flag is not set, ET separation will not occur, and the software will not automatically transition to MM 104.

It is interesting to note that the title of this procedure addresses command path as well as data path failures. Recall that a command path failure must always be shut down using the ac power switches which, in turn, creates a data path failure on that engine. Therefore, any command path failure during powered flight will become a data path failure by MECO. Note that a hydraulic or electrical lockup, in a low performance scenario, will also become a data path failure when shut down prior to MECO.

When multiple MPS command/data path failures are present at MECO, the MECO confirmed flag can be set by depressing all three main engine shutdown pushbuttons simultaneously. See figure 4-10.

Depressing the three main engine shutdown pushbuttons on panel C3 provides a manual input to the GPCs that replaces the automatic MECO confirmed flag. It is also good to know that if this procedure does not work (possibly due to a pushbutton failure), an OPS 104 PRO will also set the MECO confirmed flag.

MPS DATA
 SSME limits automaticly inhibited
 /MCC

MPS CMD, HYD or ELEC (Stuck Throttles)
 1. If in bucket: ME LIMIT SHUT DN - INH
 If one stuck throttle and > 23K
 (TAL > 22.5K/RTLS:AR = C0)
 If MPS CMD & no MCC comm:
 Man eng shudn (AC/PB)
 If MPS HYD or ELEC:
 If 1st Stage Perf NOM or
 If RILS/TAL: No action read
 If 1st Stage Perf LOW or no
 comm: Man eng shudn (AC/PB)

3. If two stuck throttles and > 23K:
 Shut down one eng (AC/PB) per
 priorities
 (1) CMD (2) HYD (3) ELEC
 If two HYD:
 If ENG/HYD: SHUTDN ENG (AC/PB)
 C/I+R/R/3
 L/2+C/I
 L/2+R/3
 If two CMD: Man shudn (AC/PB)
 2nd CMD at 24.5K

MPS DATA
 SSME limits automaticly inhibited
 /MCC

MPS

LH2 ET ULL PRESS

Post SR8 SEP/Pre MECCO
 If 3 of 3 < 31.6:
 1. MPS LH2 ULL PRESS - OP
 when 3 of 3 > 34.5 - AUTO
 If 2 of 3 > 34 & thir'd < 31.6:
 2. MPS LH2 ULL PRESS - OP
 when thir'd > 34.5 - AUTO

POST MECCO

LH2 MANF PRESS HIGH
 If MANF P LH2 > 60:
 MPS PRPLT dump seq-start ASAP
LO2 MANF PRESS HIGH
 If MANF P LO2 > 249:
 MPS PRPLT dump seq-start ASAP

AESP-11a/A/A

MULTI MPS CMD/DATA
 (No MECCO Confirm)
 Post MECCO:
 MN ENG SHUTDN pb
 (three) - push (simo)

ENG FAIL
 AC BUS SNSR (three) - OFF
 If MPS Data:
 MN ENG SHUTDN pb - push
 If second failure:
 ME LIMIT SHUTDN - INH

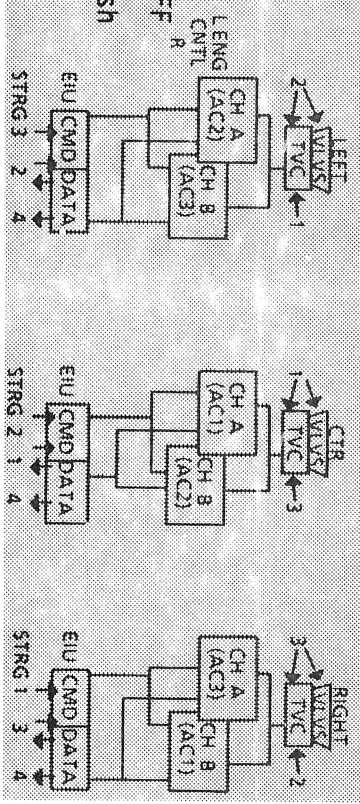
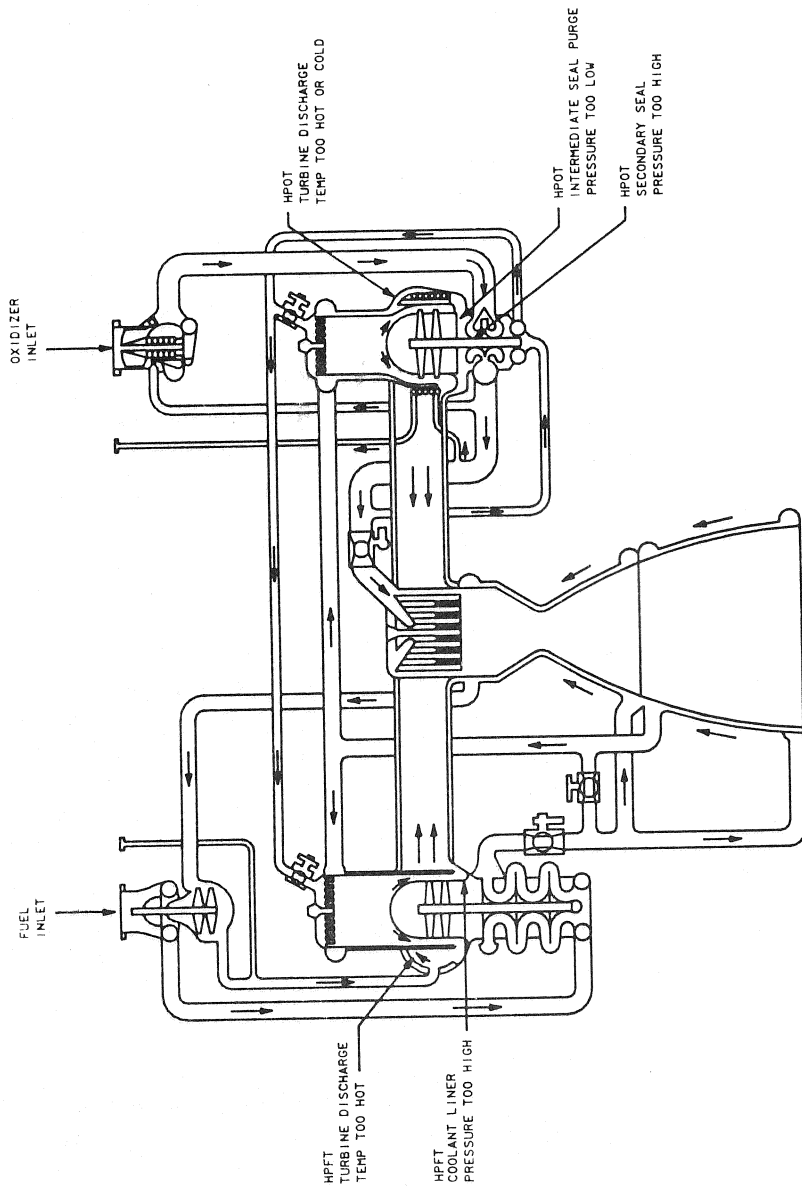

Figure 4-10. - No MECCO Confirm cue card procedure.

Engine Failure

A main engine failure will most likely be caused by a redline limit being exceeded, the failure of sensors that detect redline limits, or a main engine controller failure.

The main engine controller commands and monitors numerous engine operating parameters. Five of these parameters have been designated as critical and, for these parameters, special redline limits have been defined. See figure 4-11. Operating outside these limits can cause significant engine damage and jeopardize crew safety, so the controller is programmed to automatically shut down the engine if a limit is violated and shutdown limits are enabled.



TD3450411, ART 1

Figure 4-11. – The five main engine redline parameters.

The controller will shut down an engine that exceeds a redline limit only if the limit shutdown software is enabled. The crew can control the shutdown software with the LIMIT SHUT DN switch on panel C3. See figure 4-12. The switch has three positions: ENABLE, AUTO, and INHIBIT. The ENABLE position allows any engine which violates a redline

limit to be shut down automatically. The AUTO position allows only the first engine that violates a redline limit to be shut down; the remaining two engines will be inhibited from a redline shutdown. The INHIBIT position inhibits all redline shutdowns. The vehicle is normally flown with the LIMIT SHUT DN switch in the AUTO position.

The indications of an engine failure, due to a limit being exceeded, are a visual and audible master alarm, a red engine status light, the engine P_c meter being driven to zero, and an SSME FAIL L (C, R) CRT message. If in the second stage of flight, you should also feel a "Kick in the pants" and note a drop in acceleration.

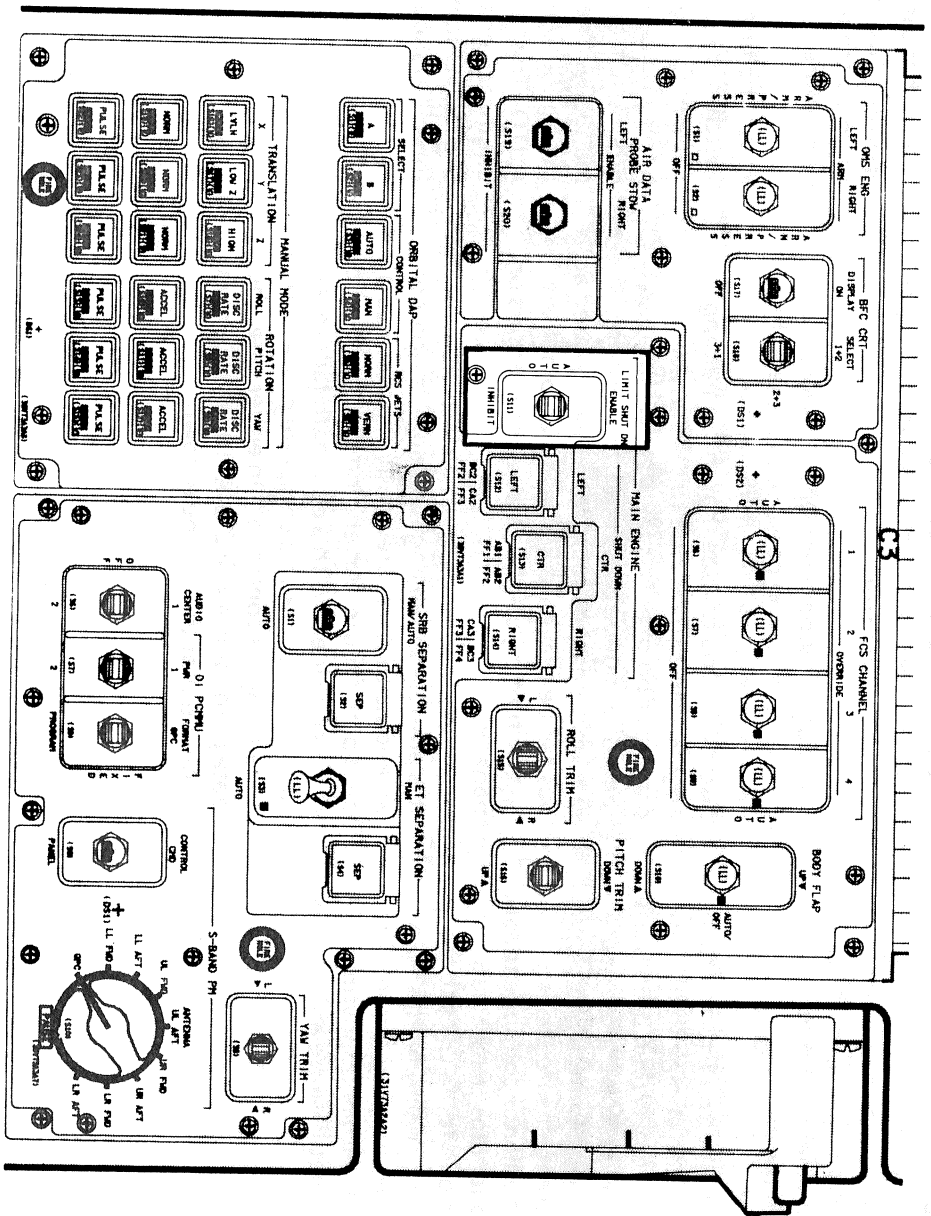

Figure 4-12. Main engine limit shutdown switch on panel C3.

If a redline limit is exceeded when limits are inhibited, the red engine status light will illuminate but the engine will not shut down. In this case, the ground will evaluate the situation, including intact abort capabilities, to determine when to shut that engine down. There are some cases when an engine can still be operated safely even when a redline limit is exceeded, but only under close and continuous scrutiny by ground controllers. Also, a failed sensor can give all the indications of an exceeded redline (including engine shutdown if limits are enabled) when there is actually no serious problem with the engine.

A complete power failure to the main engine controller will result in an engine shutdown even if limits are inhibited. When both DCUs in a controller lose power, the engine goes through an immediate pneumatic shutdown. This is a safety feature to ensure that an uncontrolled engine will not continue to run. Also, when a controller fails, a data path failure results which blinds the GPCs to the engine status. In short, an engine has failed and the GPCs are unaware. This is one reason to immediately check with MCC anytime indications of a data path failure are received.

The crew response to a main engine failure is to protect the remaining engine(s) and, if required, inform the GPCs that the engine is down. See figure 4-13.

Each main engine controller is powered by two of the three ac buses, one for each DCU. The loss of any one bus will result in a loss of controller redundancy on two engines and the loss of any two buses will cause the associated engine to shut down.

In a situation where one engine is lost, you must do everything possible to protect the remaining engines. From the above discussion, you can see that the remaining engines can also fail due to the correct combination of ac bus failures. While a bus failure cannot be prevented, bus sensor malfunctions that could take down a good ac bus can be prevented. The PLT accomplishes this by turning off the three ac bus sensors on panel R1.

It is possible for an engine failure to occur on an engine that has previously experienced a data path failure. An engine failure can also occur coincident with a data path failure, as would be the case in a complete power loss to a main engine controller. In either case, the data path failure will prevent the GPCs from knowing that the engine is down.

It is very important that the GPCs be notified of an engine failure since guidance and flight control change their processing based on the number of operating engines. Depressing the appropriate main engine shutdown push-button on panel C3 will notify the GPCs that the engine is down.

If a second engine should fail, it is even more critical that the remaining engine continue to operate. Taking the main engine limit shutdown switch to INHIBIT ensures that there will be no more automatic engine shutdowns.

When the first engine fails and the limit switch is in AUTO, the redline limits on the remaining engines are inhibited. Later, when single engine TAL capability is achieved, the ground will call for the crew to reenable limits manually. The limits will be reenabled by taking the limit switch to ENABLE and then AUTO. This resets the logic on the remaining engines to enable, thus allowing the limits on the last remaining engine to automatically be inhibited should a second engine shutdown.

MPS DATA
 SSME limits automati-
 cally inhibited
 /MCC

MPS

LH2 ET ULL PRESS

Post SRB SEP/pre MECO
 If 3 of 3 < 31.6:
 1. MPS LH2 ULL PRESS - OP
 when 3 of 3 > 34.5 - AUTO
 If 2 of 3 > 34 & third < 31.6:
 2. MPS LH2 ULL PRESS - OP
 when third > 34.5 - AUTO

POST MECO

LH2 MANIF PRESS HIGH
 If MANF P LH2 > 60:
 MPS PRPLT dump seq-start ASAP
LO2 MANIF PRESS HIGH
 If MANF P LO2 > 249:
 MPS PRPLT dump seq-start ASAP

AESP-11a/A/A

MPS CMD, HYD or ELEC (Stuck Throttles)
 1. If in bucket: ME LIMIT SHUT DN - INH
 If one stuck throttle and > 23K
 (TAL > 22.5K/RTLS:AR = C0)
 If MPS CMD & no MCC comm:
 Man eng shutdn (AC/PB)
 If MPS HYD or ELEC:
 If 1st Stage Perf NOM or
 RTLS/STAL: No action reqd
 If 1st Stage Perf LOW or no
 Comm: Man eng shutdn (AC/PB)

3. If two stuck throttles and > 23K:
 Shut down one eng (AC/PB) per
 priorities
 (1) CMD (2) HYD (3) ELEC

If two HYD:
 ENG/HYD
 C/T+R/3
 L/2+C/1
 L/2+R/3
 If two CMD: Man shutdn (AC/PB)
 2nd CMD at 24.5K

MULTI MPS CMD/DATA
 (No MECO Confirm)

Post MECO:
 MN ENG SHUTDN pb
 (three) - push (simo)

ENG FAIL
 AC BUS SNSR (three) - OFF
 If MPS Data:
 MN ENG SHUTDN pb - push
 If second failure:
 ME LIMIT SHUTDN - INH

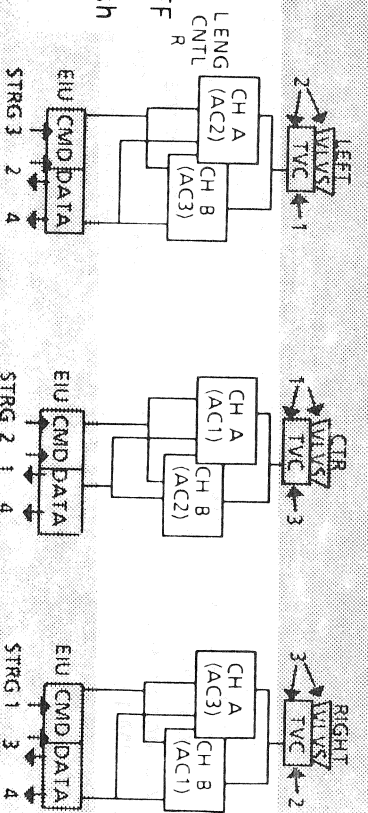

Figure 4-13.- ENGINE FAIL cue card procedure and ac bus distribution to the main engine controllers.

LH2 ET ULL PRESS

Ullage is the space in the tank not occupied by LH2. This procedure is accomplished when the LH2 ullage pressure falls below the acceptable limit of 31.6 psia.

Pressure in the LH2 ET is maintained between 32 and 34 psia by GH2 from the three main engines. There are three flow control valves (one for each engine) that modulate the flow of GH2 to the tank. Each flow control valve is driven by its own ullage pressure sensor at the top of the LH2 tank. When a sensor sees the pressure drop to 32 psia, its corresponding valve opens; when pressure builds back up to 34 psia, the valve closes.

Low LH2 ullage pressure can be caused by a tank leak, a tank vent failed open, sensor failures, or flow control valve failures. This situation is dangerous because without sufficient pressure at the engine inlets, the fuel turbopumps can cavitate causing one or more engines to fail, possibly with uncontained damage.

The indications of low LH2 ullage pressure are an SM alert light and tone, one or more down arrows (v) by the LH2 ullage pressure readings on the BFS GNC SYS SUMM 1 display, and an MPS LH2/O2 ULL message on the CRT.

Crew response to low LH2 ullage pressure is to override the auto pressurization system by taking the LH2 ULLAGE PRESS switch on panel R2 to OPEN. See figure 4-14.

When LH2 ullage pressure fails low, check with MCC first. They can see the actual position of the flow control valves, and therefore have more insight into the problem. Also, the procedure should not be accomplished prior to SRB separation. Since the tank is pressurized to 42 psia with helium prior to launch, there is little potential for low ullage pressure prior to staging. In fact, manually opening the flow control valves could overpressurize the tank causing GH2 to vent overboard. This could be hazardous when still in the denser part of the atmosphere.

If SRB separation has occurred and all three of the LH2 ullage pressure sensors indicate less than 31.6 psia on the BFS GNC SYS SUMM 1 display, take the LH2 ULLAGE PRESS switch to OPEN. The flow control valves should have opened automatically when the pressure dropped to 32 psia. This action overrides the automatic system and drives the valves open manually. Then, when the three pressure sensors indicate greater than 34.5 psia, return the switch to AUTO. The three valves should then close, preventing an overpressure in the tank.

If two of the three sensors read greater than 34 psia and the third reads less than 31.6, the previously mentioned actions are the same but for different reasons. In this case, the flow control valves driven by the sensors reading greater than 34 psia should be closed. But it is unlikely the ullage pressure will maintain 34 psia with two valves closed. Therefore, it is assumed that those two sensors have failed high, their associated flow control valves are closed, and the third sensor (reading low) is correct.

In either of the above cases, if the ullage pressure continues to drop after the LH2 ULLAGE PRESS switch is placed in open, MCC will probably direct manual throttle reduction. At reduced throttle settings, the pressure required at the engine inlets is also lower.

There is no cue card procedure for any other ullage pressure system malfunctions. If one of the sensors indicates high or low and the other two are normal, then that sensor is assumed failed and no crew action is required. If all three sensors indicate high pressure, it is assumed that the flow control valves are failed open. In this case, the pressure should stabilize at 37 psia when the LH2 tank vent opens. The crew has no manual close capability for the flow control valves.

Note that there is no procedure for low LO2 ullage pressure. Since the LO2 tank sits on the top of the ET and the LO2 density is much greater than LH2, there is little potential for low LO2 pressure at the engine inlets.

MPPS DATA
 SSME limits automatic
 callly inhibited
 /MCC

MPPS

MPPS CMD, HYD or ELEC (Stuck Throttles)
 1. If in bucket: ME LIMIT SHUT DN - INH
 If one stuck throttle and > 23K
 (TAL > 22.5K/RTLS:DR = C0)
 If MPS CMD & no MCC comm:
 Man eng shudn (AC/PB)
 If MPS HYD or ELEC:
 If 1st Stage Perf NOM or
 RTLS/TAL: No action reqd
 If 1st Stage Perf LOW or no
 comm: Man eng shudn (AC/PB)
 3. If two stuck throttles and > 23K:
 Shut down one eng (AC/PB) per
 priorities
 (1) CMD (2) HYD (3) ELEC
 If two HYD:
 ENG/HYD SHUTDN ENG (AC/PB)
 C/1+R/3
 L/2+C/1
 L/2+R/3
 If 2nd CMD: Man shudn (AC/PB)
 2nd CMD at 24.5K

LH2 ET ULL PRESS
 /MCC
 Post SRB SEP/Pre MECO
 If 3 of 3 < 31.6:
 1. MPS LH2 ULL PRESS - OP
 when 3 of 3 > 34.5 - AUTO
 If 2 of 3 > 34 & third < 31.6:
 2. MPS LH2 ULL PRESS - OP
 when third > 34.5 - AUTO

MULTI MPPS CMD/DATA
 (No MECO Confirm)
 Post MECO:
 MN ENG SHUTDN pb
 (three) - push (simo)

POST MECO
LH2 MANF PRESS HIGH
 If MANF P LH2 > 60:
 MPS PRPLT dump seq-start ASAP
LOZ MANF PRESS HIGH
 If MANF P LO2 > 249:
 MPS PRPLT dump seq-start ASAP
 AESP-11a/A/A

ENG FAIL
 AC BUS SNSR (three) - OFF
 If MPS Data:
 MN ENG SHUTDN pb - push
 If second failure:
 ME LIMIT SHUTDN - INH

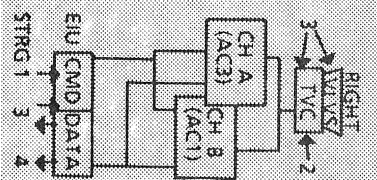
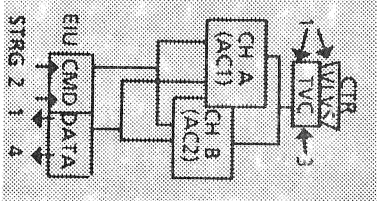
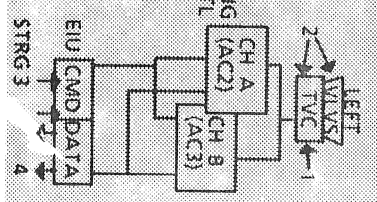

Figure 4-14.- LH2 ET ULL PRESS cue card procedure.

LH2 /LO2 MANF PRESS High

After MECO, LH2 and LO2 manifold pressures rise due to heat soakback from the engines. Failure to relieve that excess pressure will result in the LH2/O2 manifold alarm.

At MECO, the LH2 and LO2 feedline relief isolation valves open, allowing their respective relief valves to operate. See figure 4-15. The LH2 side relieves at 40-55 psig, and the LO2 side relieves at 190-220 psig. Also, since LH2 is more susceptible to overpressure than LO2, the backup LH2 dump valves open to provide extra protection. If all these valves operate correctly, the feedline manifold pressures will remain within limits until the MPS propellant dump occurs.

If one of the manifolds fails to relieve properly, it is possible that the pressure could build beyond limits. High LH2 manifold pressure will annunciate at 60 psia. LO2 annunciates at 249 psia. If left uncorrected, the high pressure could cause the manifold to rupture.

The indications of high LH2 or LO2 manifold pressure are a master alarm, an up arrow (↑) by the applicable manifold pressure reading on the BFS GNC SYS SUMM 1 display, and an MPS LH2/O2 MANF message on the CRT.

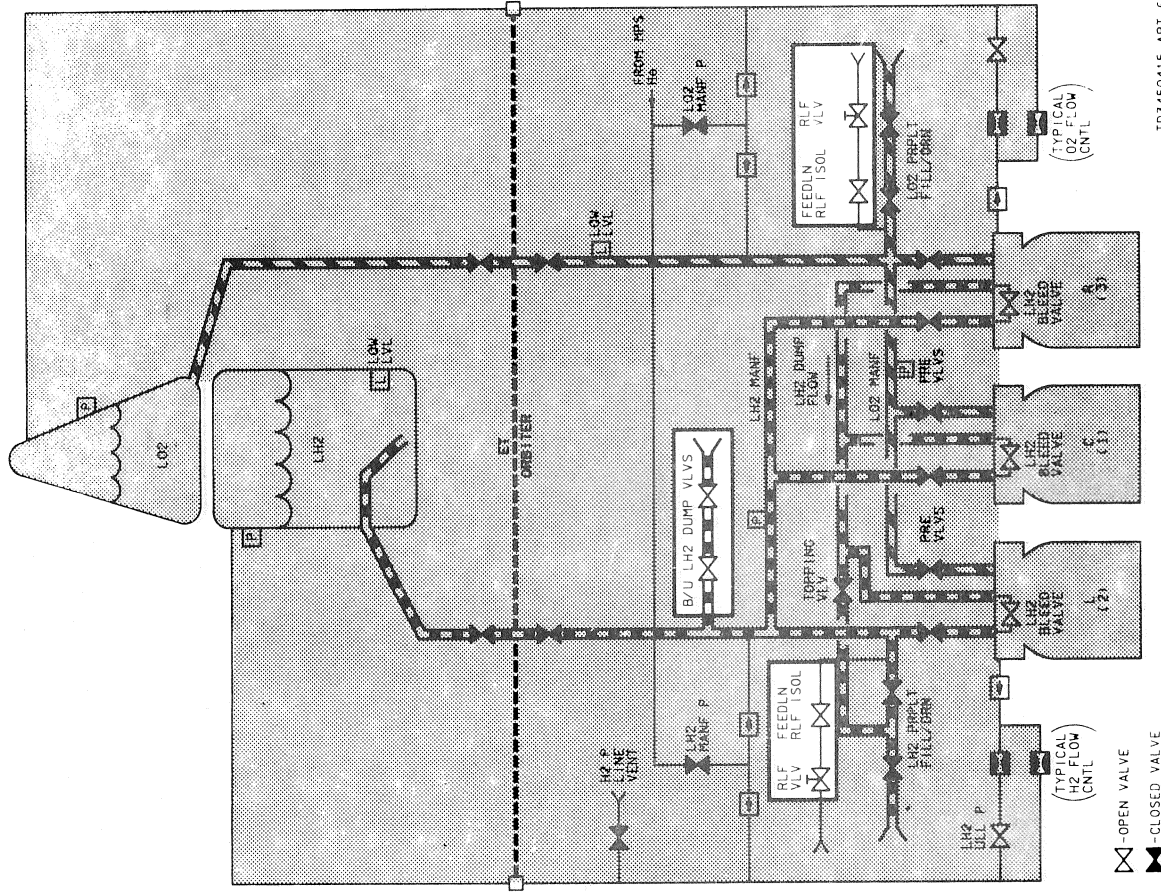

TD3450415.ART.6

Figure 4-15. – The feedline relief isolation valves and backup LH2 dump valves open post-MECO to relieve manifold pressure.

When the LH2/LO2 manifold alarm sounds post-MECO, the PLT should immediately take the MPS PROPELLANT DUMP switch on panel R2 to sequence START. See figure 4-16.

The quickest way to relieve the pressure in a feedline manifold is to accomplish an MPS propellant dump. This allows the trapped LH2 to exit through the fill/drain valves and the LO2 through the engine nozzles. Although you may be dumping sooner than you intended, you will relieve the critical manifold pressure and, at the same time, still get a complete MPS dump.

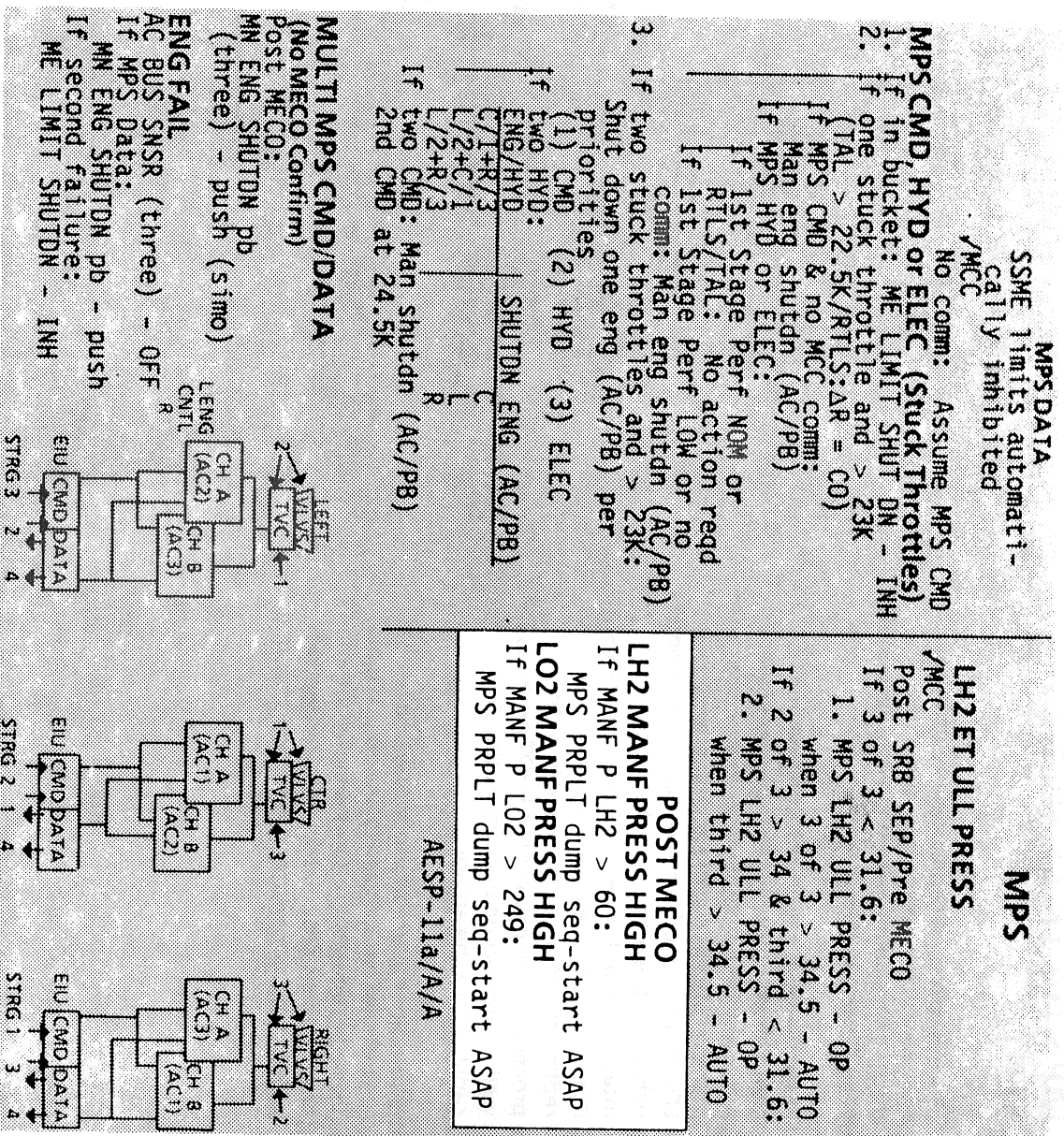

Figure 4-16 - LH2/LO2 MANF PRESS HIGH cue card procedure.

MPS He TK LK (Pre-ET SEP)

This procedure is applicable anytime prior to ET separation when pressure in one of the three main engine helium tanks is decreasing at an abnormally high rate.

Refer to figure 4-17. Each main engine has its own helium supply system. During powered flight, the helium provides a continuous purge of the HPOT intermediate seal, preventing LO2 in the pump from mixing with hydrogen-rich gas in the turbine. If the purge is interrupted or the helium pressure in the seal drops too low, the engine will experience a redline shutdown. The purpose of this procedure is to protect the HPOT purge as well as the backup pneumatic shutdown capability of the engines.

Although the title of this procedure implies that it is for helium tank leaks only, it is also used for regulator failures and leaks in the distribution lines. There is no C&W protection or leak isolation procedure for the pneumatic helium system.

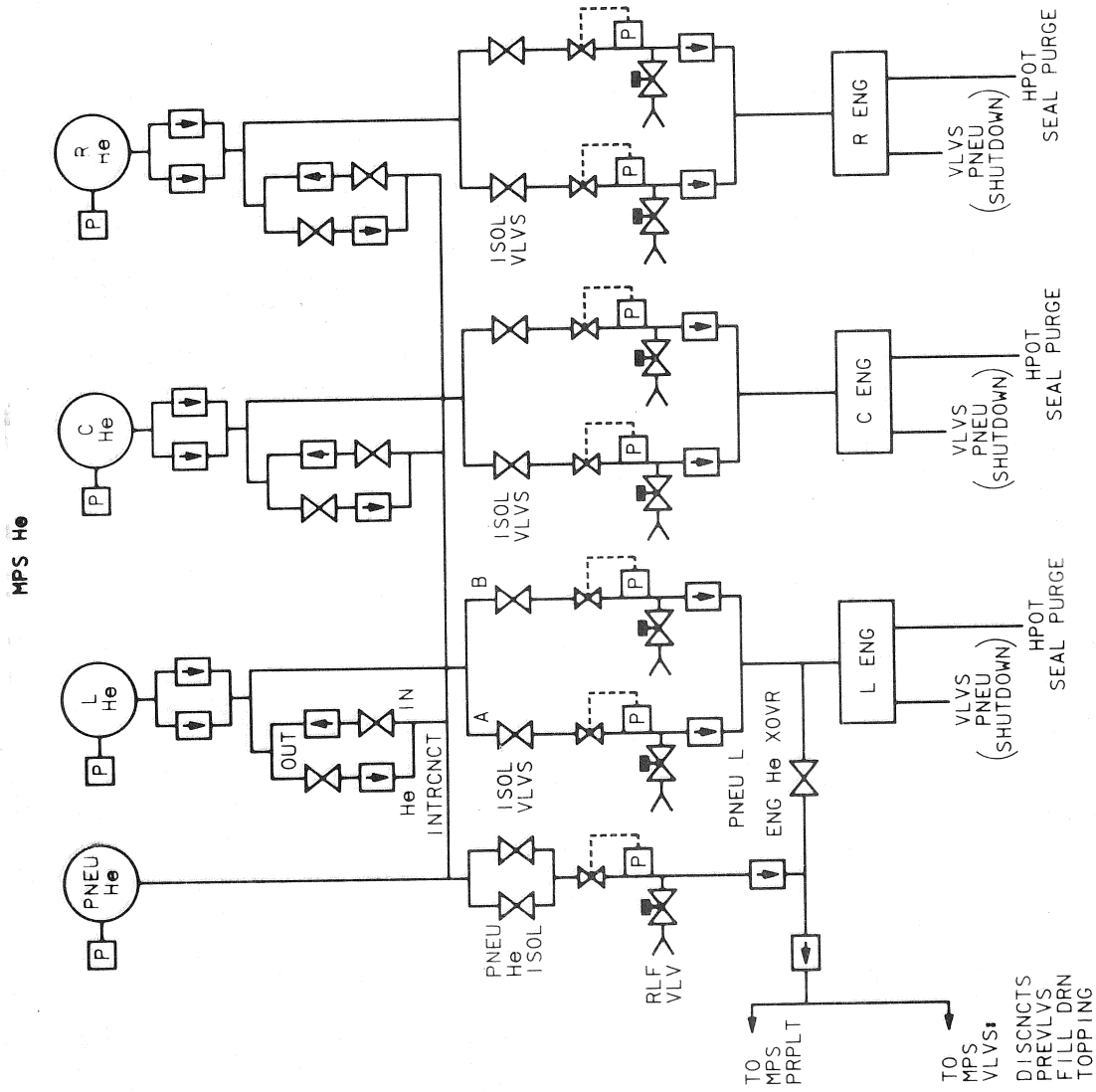

TD3450417, ART, 3

Figure 4-17. – Each main engine has its own helium supply system with dual redundant regulator legs.

The indications of an MPS helium tank leak are an SM alert light and tone, an up arrow (↑) by the applicable dp/dt on the BFS GNC SYS SUMM 1 display, and an MPS He P C (L,R) message on the CRT. Also, if a regulator goes out of limits, an up or down arrow will appear next to the applicable CRT reading. When a helium tank pressure drops below 1150 psia, a down arrow (↓) will appear accompanied by a master alarm.

The crew's first response to a helium leak is to attempt to isolate the leak. If unsuccessful, protect the helium supply to that engine by interconnecting to the pneumatic helium system. See figure 4-18.

When entering the procedure, if a regulator is operating outside of its limits, close the affected helium isolation valve with the switch on panel R2. This will eliminate one of the redundant helium legs but should also stop the leak.

<p>MPS He TK LK Pre ET SEP If He REG P + or ↑: 1. Affected He ISOL-CL Otherwise: 2. He ISOL A - CL If no decr in dp/dt: 3. He ISOL A - OP B - CL No decr in dp/dt: 4. He ISOL B - OP If TK P < 1100: 5. Affected He I'CONNECT - IN OP At ET SEP: 6. He I'CONNECT - GPC >></p>

Figure 4-18. - Cue card procedure for an MPS helium leak (pre-ET SEP)

If there is no indication of a regulator out of limits, resort to the "hit and miss" method. Close the A isolation valve and look for a decrease in dp/dt. The dp/dt is the best indicator of helium leaks. Normal dp/dt (change in pressure of the helium tank over time) is 12 psia every 3 seconds. Since dp/dt is displayed in multiples of 10, the nominal CRT reading is 10. The SM alert annunciates if it goes over 20. See figure 4-19.

If dp/dt does not decrease after closing the A isolation valve, the leak has not been found. Reopen the A valve and close the B. It is critical that you do not close both isolation valves at the same time. Doing so will cut off the flow of helium to the engine resulting in a redline shutdown.

If dp/dt does not decrease after closing the B isolation valve, the leak cannot be isolated. If the leak is large enough to reduce tank pressure to 1100 psi, interconnect the affected helium system to the pneumatic helium supply. Recall that you will get a master alarm when the leaking helium tank pressure reaches 1150 psi to warn you that the time has come to interconnect. This is done by taking the affected engine helium interconnect switch on panel R2 to IN OPEN.

After MECO, helium is still required to perform a 6-second purge of the HPOTs. Using ET separation as a cue that the purge is complete, return the helium interconnect switch to GPC. Immediately after ET separation, all of the interconnects are commanded to OUT OPEN by the GPCs.

This way, all the helium systems join the common manifold to support the MPS propellant dump. If the leaking system was left IN OPEN, it is possible that all the remaining helium systems could be depleted feeding a leak.

```

1021/ /018 GNC SYS SUMM 1 5 000/00:07:54
BFS 000/00:00:00
SURE POS MOM
L OB XXX.XS XXS
IB XXX.XS XXS
R IB XXX.XS XXS
OB XXX.XS XXS
ALL XXX.X
RUD XXX.X
SPD BRK XXX.X
BDY FLP XXX.X

MPS L C R
HE TK P 4060 3970 4060
REG P A 760 760 760
B 760 760 760
dP/dT 10 30 10
ULL P LH2 33.7 33.7 33.7
L02 21.5 21.5 21.5

MANF P LH2 33
L02 55

MPS HE P C
SYS SUMM
DPS 1 2 3 4
MDM FF S S S S
FA S S S S
PL S S S
FCS CH 1 2 3 4
NAV 1 2 3 4
IMU S S S
TAC S S S
ADTA S S S
5 19:46:03

```

TD3450419. ART, 3

Figure 4-19. - Indications of a center engine helium leak on the BFS GNC SYS SUMM 1. Since both regulators appear normal, the "hit and miss" method is required for leak isolation.

MPS He TK LK (Post-ET SEP)

This procedure is applicable anytime after ET separation when an MPS helium leak is indicated.

Refer to figure 4-20. If the tank pressure drops below 1100 psi, close the A and B isolation valves for that system. This may isolate the leak. This step is only necessary if the MPS powerdown procedure has not been accomplished when all of the helium isolation valves (except pneumatics) are closed.

Recall that after ET separation, all the helium systems are manifolded together to support the MPS dump. If a leak develops somewhere in the pneumatic system, it will deplete all the helium supply tanks. So if a second tank pressure drops below 1100 psi (reason to suspect a pneumatic leak), isolate the pneumatic system by closing the pneumatic helium isolation valves. This action is not performed for a TAL abort because it would inhibit the entry aft compartment purge.

None of this procedure is accomplished for an RTLS abort for two reasons. First, an RTLS is a short duration flight; so, unless the leak is very large, the helium supply will probably be sufficient to support the full mission. Second, accomplishing these procedures during an RTLS would add to an already demanding workload for the crew.

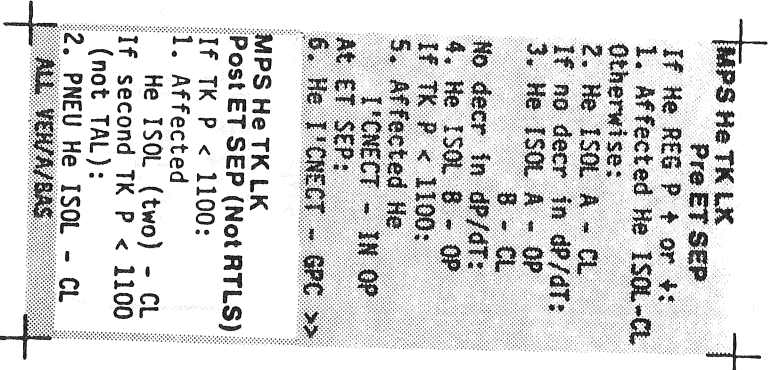

Figure 4-20. – Cue card procedure for an MPS helium leak (post-ET SEP).

ET SEP MAN

In OPS 1, if the ET SEP switch fails, it defaults to MANUAL. If the switch fails in OPS 6, it defaults to AUTO.

The ET SEP cue card is used to correct ET SEP switch failures only. If an ET SEP inhibit occurs post-MECO, you should refer to the ascent procedures section of the pilot's flipbook. If the ET SEP switch fails in OPS 1, it defaults to MANUAL. This means that, regardless of the physical position of the switch, the software will see it in MANUAL. In OPS 6, in order not to add to an already heavy workload, the switch will default to AUTO. Also, if the switch fails in OPS 1 and defaults to MANUAL and the crew subsequently aborts RTLS, the default position will automatically change to AUTO.

The indications of an ET SEP switch failure in OPS 1 are an SM alert light and tone, and an ET SEP MAN message on the CRT. In OPS 6, the SM alert is accompanied by an ET SEP AUTO message.

Your response to an ET SEP MAN message is to mode the ET SEP software back to AUTO post-MECO. There is no crew response to an ET SEP AUTO message. See figure 4-21.

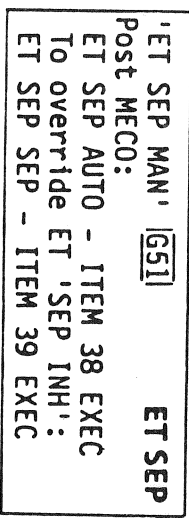

Figure 4-21. – The ET SEP cue card.

You can override an ET SEP MAN message on the SPEC 51 OVERRIDE display. See figure 4-22. An item 38 EXEC after MECO will drive the software back to AUTO, and the normal ET separation sequence will begin. Do not execute item 38 prior to MECO to avoid the consequences of an input error.

The next part of the ET SEP cue card can be misleading. If, after item 38 EXEC, an ET SEP INH message is received, do not accomplish an item 39 EXEC.

Instead, reference the ascent procedures section in the pilot's flipbook to determine if there is a problem with rates or a feedline disconnect valve failure. After accomplishing those procedures, if the tank still cannot be separated, then an item 39 EXEC is in order.

1011/051/		OVERRIDE		1 175/11 27 30	
ABORT MODE	1	ENTRY FCS		000/00 02 30	
TAL/AOA	2	FILTER	ATMOSPHERE		
ATO	3	NOM 20*	NOM	22*	
ABORT	4	ALT 21	N POLE	23	
MAX THROT	4		S POLE	24	
PROPLT DUMP		IMU STAT	ATT DES	PRL	
OMS DUMP TTG	0	1	2	25	SYS AUT DES
ENA ICNCT	5	2	26	26*	1 28*
CONT CENT		3	27	27	2 29*
ABT	6				3 30*
ARM	7	ADTA	H	α	M
START	8*	L	1		34
INERT		R	2		35
STOP			3		36
AFT RCS	13				37
14 TIME		ET SEP		ROLL MODE	AUTO
FWD RCS	15	AUTO	38	AUTO SEL	42
16 TIME		SEP	39		
		UMB DR	40	VENT DOOR	CNTL
		CLOSE		OPEN	43*
		RCS RM MANF		CLOSE	44
		CL OVRD	41		

TD3450422. ART, 2

Figure 4-22. - ET SEP functions on the SPEC 51 OVERRIDE display.

ET SEP INH

An ET SEP inhibit would most likely be due to vehicle rates out of limits or a feedline disconnect valve failure.

Refer to figure 4-23. The automatic ET separation sequence will be inhibited if the vehicle rates exceed 0.7 deg/s in any axis, or if one of the feedline disconnect valves between the Orbiter and the tank fails to close. If rates are the problem, you should correct them to within limits and separate the tank. If one of the disconnect valves fails, it is not safe to separate prior to 6 minutes after MECO. This time allows the pressure in the ET to dissipate, eliminating the danger of the tank's rotating into the Orbiter after separation.

ASCENT PROCEDURES

R180 LVLH ..

0.6M	✓Pc	→	65%
1.2M	✓Pc	→	104%

* PC < 50' (✓rates < 5:2.2)
 (Backup AUTO SEP 2:20)
 * 'SEP INH' + 5 sec - MAN SRB SEP *

✓MECO

* NOT STABLE (10 sec)
 * NO COMM - CSS & MAN THROT *

3:00 ✓EVAP OUT (T < 60)

MECO ✓VI = 25871

* If Man Throttle (3 eng)
 * Man Shudn at 25750

ET SEP (MECO+18)

* 'SEP INH'
 * ET SEP - MAN *
 * OPS 104 - PRO (✓BFS 104) *
 * Rates > .7, .7, .7: *
 * NU11 rates *
 * ET SEP - SEP *
 * Rates < .7, .7, .7: *
 * Assume Feedline Fail *

MM104 ✓TGTS

* If OMS 1 reqd: *
 * Go to OMS 1 BURN *

Figure 4-23. - When an ET SEP INH occurs, the crew should reference the ASCENT PROCEDURES card, found in the Ascent Checklist and pilot flipbook, before proceeding.

The indications of an ET SEP inhibit are an SM alert light and tone and an ET SEP INH message on the CRT.

When faced with an ET SEP INHIBIT due to a feedline disconnect fail, the crew must accomplish delayed OMS 1 procedures in the Ascent Checklist.

When the ET fails to separate, the software will not automatically mode to MM 104. So, after determining that vehicle rates are within limits (feedline disconnect fail assumed), manually PRO to OPS 104. Then the PLT will take the ET SEP switch to MANUAL to prevent an unwanted automatic separation. An MPS propellant dump is performed to relieve the pressure in Orbiter lines and, after waiting 6 minutes for ET pressure to dissipate, separate the tank manually.

Dummy OMS Burn

For flights requiring an OMS 1 burn, the MPS propellant dump is started automatically at OMS 1 ignition. For direct insertion flights (no OMS 1 required), the crew must manually start the dump using the MPS PRPLT DUMP switch on panel R2. If the switch fails, an alternate method for dumping the propellants must be used.

The DUMMY OMS BURN procedure is used to start the MPS propellant dump sequence when the DUMP switch is inoperable and an OMS 1 burn is not required.

The dummy OMS burn fools the MPS dump software into thinking that an OMS 1 burn has started. The crew sets up for a burn on the OMS maneuver display but leaves the OMS switches on panel C3 in the OFF position. See figure 4-24. Five seconds prior to time of ignition (TIG), a + X RCS burn is commanded to settle the propellants. At TIG, the MPS dump start command is sent and the OMS + on the maneuver display indicates that the OMS engines did not light. At this time, the + X burn is terminated. The dump will continue through its normal cycle.

MPS DUMMY OMS BURN (Pass only)

✓/Load TIG
TIG-2:
✓MPS dump seq - GPC
OMS ENG (two) - OFF
TIG-:15 EXEC
TIG-:05 +X until OMS +

Figure 4-24. – The DUMMY OMS BURN procedure is located in the MPS section of the Ascent/Entry Systems Procedure and the OMS section of the pilot flipbook.

MPS C&W

A pressure buildup in the LH2 or LO2 manifold while onorbit can result in the MPS C&W alarm.

This malfunction is the result of an incomplete propellant dump and vacuum inerting and failure of the relief valves to vent excess pressure. If the LH2 manifold pressure

exceeds 60 psia or the LO2 pressure exceeds 249 psia while onorbit, the MPS C&W alarm will annunciate.

Indications of this malfunction are a master alarm, an MPS C&W light, and a high pressure reading on the LH2 or LO2 manifold pressure meter.

Crew response to an MPS C&W alarm is to accomplish a second vacuum inerting procedure.

This procedure is found in the Orbit Pocket Checklist. See figure 4-25. The commander's instrument power switch must be placed in FLT/MPS in order to read the LH2 (LO2) manifold pressure on the meters. Also, the pneumatic helium isolation valves must be opened so helium is available to operate the propellant fill/drain valves. The vacuum inerting will be allowed to continue for 30 minutes after which the fill/drain valves and the pneumatic helium isolation valves will be closed. Step 4 directs you to the long form Malfunction Procedures for further troubleshooting and vacuum inerting termination.

MPS CW

1. CDR INST PWR - FLT/MPS
✓MPS PRESS LH2(LO2) - (note reading)
2. PNEU He ISOL - OP
3. PRPLT FILL/DRAIN LH2 OUTBD - OP
LO2 OUTBD - OP
4. Go to MAL, MPS, 12.1 I.I.1

Figure 4-25. – The MPS C&W procedure from the Orbit Pocket Checklist.

Questions

1. List the MPS malfunction procedures found in the Ascent Pocket Checklist.
2. Which MPS malfunctions cause the amber engine status light on panel F7 to illuminate?
3. Which of the three stuck throttles (MPS CMD, HYD, or ELEC) must always be shut down manually prior to, or at, MECO? Why?
4. If there are two data path failures at MECO and one main engine shutdown pushbutton is inoperable due to a control bus failure, how can you set the MECO confirmed flag?
5. If the limit shutdown switch is in AUTO and one engine fails, what happens to the redline limits on the remaining two engines?
6. What is the crew response to low LH2 ullage pressure?
7. What is the best indicator of an MPS helium tank leak?
8. If the ET separation switch fails, what position does the software default to in OPS 1? In OPS 6?
9. MECO has just occurred and an ET SEP INH message is received. Where is the procedure that should be referenced?

Answers

1. List the MPS malfunction procedures found in the Ascent Pocket Checklist.
There are no MPS malfunction procedures in the Ascent Pocket Checklist. All MPS malfunction procedures for ascent are found on cue cards and in the pilot flipbook.
2. Which MPS malfunctions cause the amber engine status light on panel F7 to illuminate?
A data path failure, command path failure, hydraulic lockup, and electrical lockup will all cause the amber status light to illuminate. Note that these are the first four malfunctions listed on the MPS cue card.
3. Which of the three stuck throttles (MPS CMD, HYD, or ELEC) must always be shut down manually prior to, or at, MECO? Why?
The command path failure (MPS CMD) must always be shut down manually prior to MECO because it is not capable of responding to any GPC commands, including the MECO command.
4. If there are two data path failures at MECO, and one main engine shutdown pushbutton is inoperable due to a control bus failure, how can you set the MECO confirmed flag?
When multiple command/data path failures are present at MECO, the MECO confirmed flag is set by depressing all three shutdown pushbuttons simultaneously. If one of the pushbuttons is inoperable, an OPS 104 PRO will also set the MECO confirmed flag.
5. If the limit shutdown switch is in AUTO and one engine fails, what happens to the redline limits on the remaining two engines?
The redline limits on the remaining two engines are inhibited.
6. What is the crew response to low LH2 ullage pressure?
Crew response to low LH2 ullage pressure is to override the AUTO pressurization system by taking the LH2 ullage pressure switch on panel R2 to OPEN. If the pressure continues to drop, MCC will direct reducing the throttle setting manually.
7. What is the best indicator of an MPS helium tank leak?
A high helium tank dp/dt reading on the BFS GNC SYS SUMM 1 display is the best indicator of a helium leak. Note that there is no dp/dt indicator for the pneumatic helium tank.
8. If the ET separation switch fails, what position does the software default to in OPS 1? In OPS 6?
If the ET SEP switch fails in OPS 1, it defaults to MANUAL. If it fails in OPS 6, it defaults to AUTO.
9. MECO has just occurred and an ET SEP INH message is received. Where is the procedure that should be referenced?
The ET SEP INH procedure is in the Ascent Checklist on the ascent procedures page. The same page is duplicated in the pilot flipbook.

Appendix A: MPS Summary Sheet

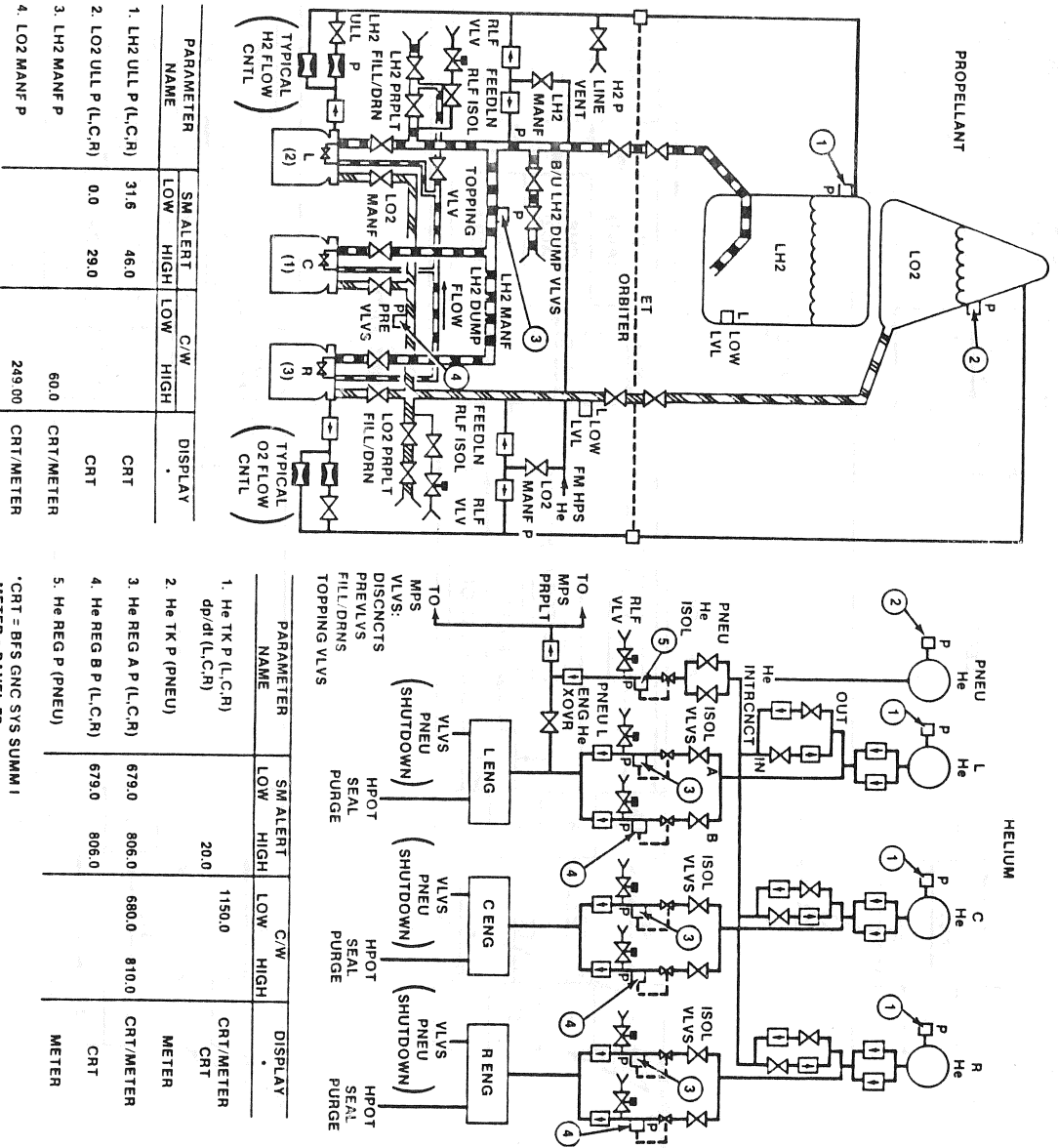

Figure A-1 - MPS propellant and helium summary.

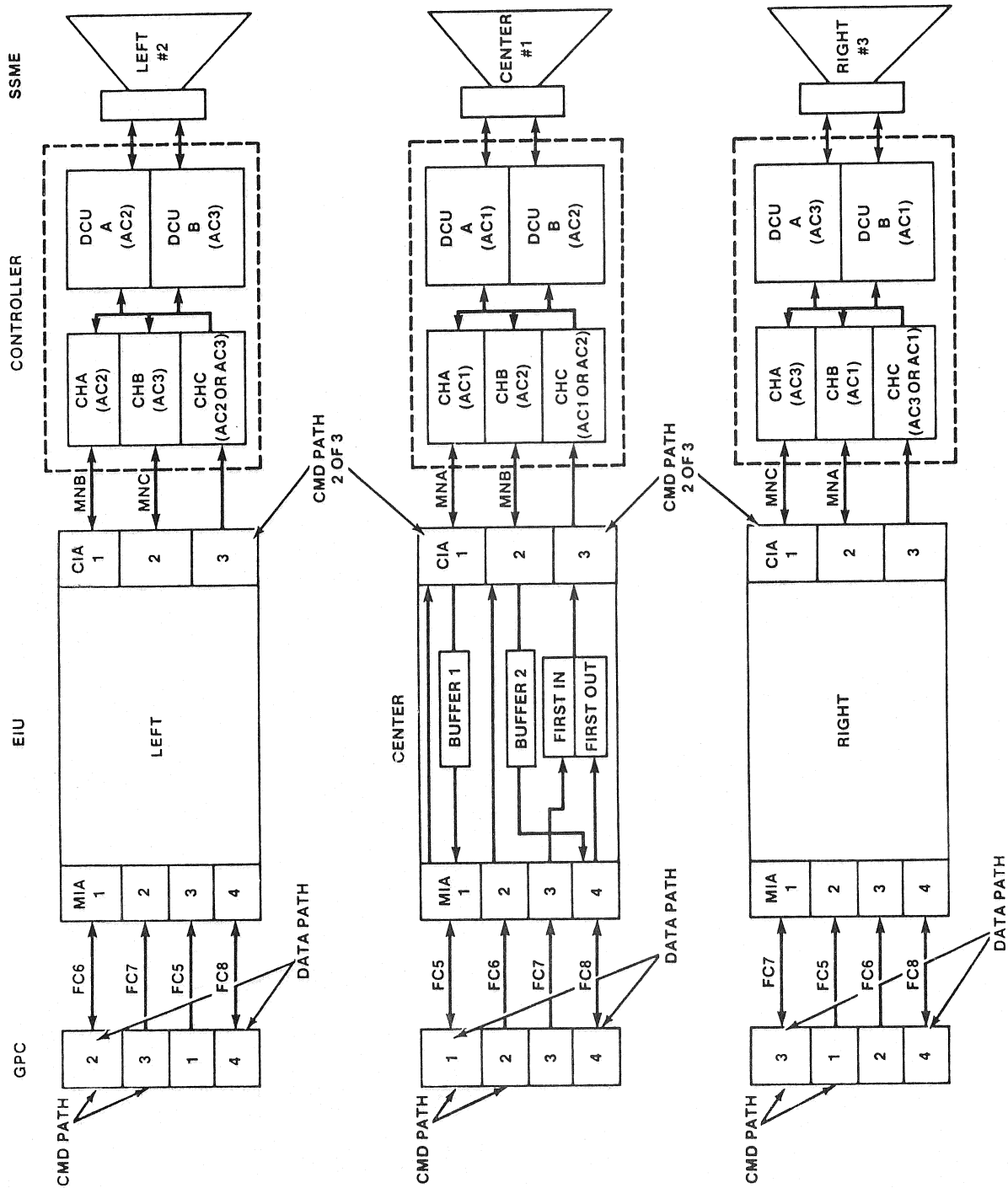

Figure A-2.- Command and data paths.

Appendix B: Acronyms and Abbreviations

ATVC	ascent thrust vector control	HPOT	high pressure oxidizer turbopump
BFS	backup flight system	LH2	liquid hydrogen
C&W	caution and warning	LO2	liquid oxygen
cb	circuit breaker	LPFT	low pressure fuel turbopump
CCV	chamber coolant valve	LPOT	low pressure oxidizer turbopump
c.g.	center of gravity	MCC	mission control center
CIA	controller interface assembly	MCC	main combustion chamber
CRT	cathode-ray tube	MDM	multipler/demultipler
DAP	digital auto pilot	MEC	master events controller
DCU	digital computer unit	MECO	main engine cutoff
DPS	data processing system	MET	mission elapsed time
EIU	engine interface unit	MFV	main fuel valve
EPS	electrical power system	MIA	multipler interface adapter
ET	external tank	MM	major mode
FC	flight critical	MOV	main oxidizer valve
FCS	flight control system	MPS	main propulsion system
FDF	Flight Data File	OMS	orbital maneuvering system
FDO	flight dynamics officer	OPB	oxidizer preburner
FF	flight forward	OPOV	oxidizer preburner oxidizer valve
FPB	fuel preburner	OPS	operational sequence
FPOV	fuel preburner oxidizer valve	PASS	primary avionics software system
GH2	gaseous hydrogen	pbi	pushbutton indicator
GO2	gaseous oxygen	Pc	chamber pressure
GPC	general purpose computer	PLT	pilot
HGM	hot gas manifold	PMS	propellant management system
HPFT	high pressure fuel turbopump	PPA	powered pitch around
		psi	pounds per square inch
		psia	pounds per square inch absolute

RCS reaction control system
RTLS return to launch site
SBTC speed brake/thrust controller
SEP separation
SM systems management
SOP subsystem operating program
SRB solid rocket booster
SSME Space Shuttle main engine
TAL transatlantic abort landing
TIG time of ignition
TVC thrust vector control
VDT vehicle data table
VIE vehicle interface electronics
WONG weight on nose gear
WOW weight on wheels

8 Other comments (or question):

7. Prior knowledge: Considerable _____ Some _____ Very little _____

6. Additions or deletions from the lesson?

5. In your opinion, was the level of detail about right?

4. Did the lesson start from your entry level?

3. Were the figures and diagrams optimum to understanding the material?

2. Comments on handout organization:

1. Was the lesson material presented in a logical manner?

Please explain any negative answers to the questions below in specific terms. Use the back of the sheet if required.

LESSON CODE 2102 DATE OF MATERIAL 10/87

LESSON CRITIQUE SHEET

MAIL TO: John T. Sims, D66

